

Deep Learning on Graphs

Yao Ma and Jiliang Tang

Contents

	<i>Preface</i>	<i>page x</i>
1	Deep Learning on Graphs: An Introduction	1
	1.1 Introduction	1
	1.2 Why Deep Learning on Graphs?	1
	1.3 What Content is Covered?	3
	1.4 Who Should Read the Book?	6
	1.5 Feature Learning on Graphs: A Brief History	8
	1.5.1 Feature Selection on Graphs	9
	1.5.2 Representation Learning on Graphs	10
	1.6 Conclusion	13
	1.7 Further Reading	13
	PART ONE FOUNDATIONS	15
2	Foundations of Graphs	17
	2.1 Introduction	17
	2.2 Graph Representations	18
	2.3 Properties and Measures	19
	2.3.1 Degree	19
	2.3.2 Connectivity	21
	2.3.3 Centrality	23
	2.4 Spectral Graph Theory	26
	2.4.1 Laplacian Matrix	26
	2.4.2 The Eigenvalues and Eigenvectors of the Laplacian Matrix	28
	2.5 Graph Signal Processing	29
	2.5.1 Graph Fourier Transform	30

2.6	Complex Graphs	33
2.6.1	Heterogeneous Graphs	33
2.6.2	Bipartite Graphs	34
2.6.3	Multi-dimensional Graphs	34
2.6.4	Signed Graphs	36
2.6.5	Hypergraphs	37
2.6.6	Dynamic Graphs	37
2.7	Computational Tasks on Graphs	39
2.7.1	Node-focused Tasks	39
2.7.2	Graph-focused Tasks	41
2.8	Conclusion	42
2.9	Further Reading	42
3	Foundations of Deep Learning	43
3.1	Introduction	43
3.2	Feedforward Networks	44
3.2.1	The Architecture	46
3.2.2	Activation Functions	47
3.2.3	Output Layer and Loss Function	50
3.3	Convolutional Neural Networks	52
3.3.1	The Convolution Operation and Convolutional Layer	52
3.3.2	Convolutional Layers in Practice	56
3.3.3	Non-linear Activation Layer	58
3.3.4	Pooling Layer	58
3.3.5	An Overall CNN Framework	58
3.4	Recurrent Neural Networks	59
3.4.1	The Architecture of Traditional RNNs	60
3.4.2	Long Short-Term Memory	61
3.4.3	Gated Recurrent Unit	63
3.5	Autoencoders	63
3.5.1	Undercomplete Autoencoders	65
3.5.2	Regularized Autoencoders	66
3.6	Training Deep Neural Networks	67
3.6.1	Training with Gradient Descent	67
3.6.2	Backpropagation	68
3.6.3	Preventing Overfitting	71
3.7	Conclusion	71
3.8	Further Reading	72

	PART TWO METHODS	73
4	Graph Embedding	75
4.1	Introduction	75
4.2	Graph Embedding on Simple Graphs	77
4.2.1	Preserving Node Co-occurrence	77
4.2.2	Preserving Structural Role	86
4.2.3	Preserving Node Status	89
4.2.4	Preserving Community Structure	91
4.3	Graph Embedding on Complex Graphs	94
4.3.1	Heterogeneous Graph Embedding	94
4.3.2	Bipartite Graph Embedding	96
4.3.3	Multi-dimensional Graph Embedding	97
4.3.4	Signed Graph Embedding	99
4.3.5	Hypergraph Embedding	102
4.3.6	Dynamic Graph Embedding	104
4.4	Conclusion	105
4.5	Further Reading	106
5	Graph Neural Networks	107
5.1	Introduction	107
5.2	The General GNN Frameworks	109
5.2.1	A General Framework for Node-focused Tasks	109
5.2.2	A General Framework for Graph-focused Tasks	110
5.3	Graph Filters	112
5.3.1	Spectral-based Graph Filters	112
5.3.2	Spatial-based Graph Filters	122
5.4	Graph Pooling	128
5.4.1	Flat Graph Pooling	129
5.4.2	Hierarchical Graph Pooling	130
5.5	Parameter Learning for Graph Neural Networks	135
5.5.1	Parameter Learning for Node Classification	135
5.5.2	Parameter Learning for Graph Classification	136
5.6	Conclusion	136
5.7	Further Reading	137
6	Robust Graph Neural Networks	138
6.1	Introduction	138
6.2	Graph Adversarial Attacks	138
6.2.1	Taxonomy of Graph Adversarial Attacks	139
6.2.2	White-box Attack	141
6.2.3	Gray-box Attack	144

6.2.4	Black-box Attack	148
6.3	Graph Adversarial Defenses	151
6.3.1	Graph Adversarial Training	152
6.3.2	Graph Purification	154
6.3.3	Graph Attention	155
6.3.4	Graph Structure Learning	159
6.4	Conclusion	160
6.5	Further Reading	160
7	Scalable Graph Neural Networks	162
7.1	Introduction	162
7.2	Node-wise Sampling Methods	166
7.3	Layer-wise Sampling Methods	168
7.4	Subgraph-wise Sampling Methods	172
7.5	Conclusion	174
7.6	Further Reading	175
8	Graph Neural Networks on Complex Graphs	176
8.1	Introduction	176
8.2	Heterogeneous Graph Neural Networks	176
8.3	Bipartite Graph Neural Networks	178
8.4	Multi-dimensional Graph Neural Networks	179
8.5	Signed Graph Neural Networks	181
8.6	Hypergraph Neural Networks	184
8.7	Dynamic Graph Neural Networks	185
8.8	Conclusion	187
8.9	Further Reading	187
9	Beyond GNNs: More Deep Models on Graphs	188
9.1	Introduction	188
9.2	Autoencoders on Graphs	189
9.3	Recurrent Neural Networks on Graphs	191
9.4	Variational Autoencoders on Graphs	193
9.4.1	Variational Autoencoders for Node Representation Learning	195
9.4.2	Variational Autoencoders for Graph Generation	196
9.5	Generative Adversarial Networks on Graphs	199
9.5.1	Generative Adversarial Networks for Node Representation Learning	200
9.5.2	Generative Adversarial Networks for Graph Generation	201
9.6	Conclusion	203

	<i>Contents</i>	vii
9.7	Further Reading	203
	PART THREE APPLICATIONS	205
10	Graph Neural Networks in Natural Language Processing	207
10.1	Introduction	207
10.2	Semantic Role Labeling	208
10.3	Neural Machine Translation	211
10.4	Relation Extraction	211
10.5	Question Answering	213
10.5.1	The Multi-hop QA Task	213
10.5.2	Entity-GCN	214
10.6	Graph to Sequence Learning	216
10.7	Graph Neural Networks on Knowledge Graphs	218
10.7.1	Graph Filters for Knowledge Graphs	218
10.7.2	Transforming Knowledge Graphs to Simple Graphs	219
10.7.3	Knowledge Graph Completion	220
10.8	Conclusion	221
10.9	Further Reading	221
11	Graph Neural Networks in Computer Vision	222
11.1	Introduction	222
11.2	Visual Question Answering	222
11.2.1	Images as Graphs	224
11.2.2	Images and Questions as Graphs	225
11.3	Skeleton-based Action Recognition	227
11.4	Image Classification	229
11.4.1	Zero-shot Image Classification	230
11.4.2	Few-shot Image Classification	231
11.4.3	Multi-label Image Classification	232
11.5	Point Cloud Learning	233
11.6	Conclusion	234
11.7	Further Reading	235
12	Graph Neural Networks in Data Mining	236
12.1	Introduction	236
12.2	Web Data Mining	236
12.2.1	Social Network Analysis	237
12.2.2	Recommender Systems	240
12.3	Urban Data Mining	244

12.3.1	Traffic Prediction	244
12.3.2	Air Quality Forecasting	246
12.4	Cybersecurity Data Mining	247
12.4.1	Malicious Account Detection	247
12.4.2	Fake News Detection	249
12.5	Conclusion	250
12.6	Further Reading	251
13	Graph Neural Networks in Biochemistry and Healthcare	252
13.1	Introduction	252
13.2	Drug Development and Discovery	252
13.2.1	Molecule Representation Learning	253
13.2.2	Protein Interface Prediction	254
13.2.3	Drug-Target Binding Affinity Prediction	256
13.3	Drug Similarity Integration	258
13.4	Polypharmacy Side Effect Prediction	259
13.5	Disease Prediction	262
13.6	Conclusion	264
13.7	Further Reading	264
	PART FOUR ADVANCES	265
14	Advanced Topics in Graph Neural Networks	267
14.1	Introduction	267
14.2	Deeper Graph Neural Networks	268
14.2.1	Jumping Knowledge	270
14.2.2	DropEdge	270
14.2.3	PairNorm	270
14.3	Exploring Unlabeled Data via Self-supervised Learning	271
14.3.1	Node-focused Tasks	271
14.3.2	Graph-focused Tasks	274
14.4	Expressiveness of Graph Neural Networks	275
14.4.1	Weisfeiler-Lehman Test	276
14.4.2	Expressiveness	278
14.5	Conclusion	279
14.6	Further Reading	279
15	Advanced Applications in Graph Neural Networks	281
15.1	Introduction	281
15.2	Combinatorial Optimization on Graphs	281
15.3	Learning Program Representations	283

	<i>Contents</i>	ix
15.4	Reasoning Interacting Dynamical Systems in Physics	285
15.5	Conclusion	286
15.6	Further Reading	286
	<i>Bibliography</i>	289
	<i>Index</i>	315

Preface

Graphs have been leveraged to denote data from various domains ranging from social science, linguistics to chemistry, biology, and physics. Meanwhile, numerous real-world applications can be treated as computational tasks on graphs. For examples, air quality forecasting can be regarded as a node classification task, friends recommendation in social networks can be solved as a link prediction task and protein interface prediction can be regarded as a graph classification task. To better take advantage of modern machine learning models for these computational tasks, effectively representing graphs plays a key role. There are two major ways to extract features to represent graphs including feature engineering and representation learning. Feature engineering relies on hand-engineered features, which is time-consuming and often not optimal for given downstream tasks. While representation learning is to learn features automatically, which requires minimal human efforts and is adaptive to given downstream tasks. Thus, representation learning on graphs has been extensively studied.

The field of graph representation learning has been greatly developed over the past decades that can be roughly divided into three generations including traditional graph embedding, modern graph embedding, and deep learning on graphs. As the first generation of graph representation learning, traditional graph embedding has been investigated under the context of classic dimension reduction techniques on graphs such as IsoMap, LLE, and eigenmap. Word2vec is to learn word representations from a large corpus of text and the generated word representations have advanced many natural language processing tasks. The successful extensions of word2vec to the graph domain have started the second generation of representation learning on graphs, i.e., modern graph embedding. Given the huge success of deep learning techniques in representation learning in the domains of images and text, efforts have been

made to generalize them to graphs, which have opened a new chapter of graph representation learning, i.e., deep learning on graphs.

More and more evidence has demonstrated that the third generation of graph representation learning especially graph neural networks (GNNs) has tremendously facilitated computational tasks on graphs including both node-focused and graph-focused tasks. The revolutionary advances brought by GNNs have also immensely contributed to the depth and breadth of the adoption of graph representation learning in real-world applications. For the classical application domains of graph representation learning such as recommender systems and social network analysis, GNNs result in state-of-the-art performance and bring them into new frontiers. Meanwhile, new application domains of GNNs have been continuously emerging such as combinatorial optimization, physics, and healthcare. These wide applications of GNNs enable diverse contributions and perspectives from disparate disciplines and make this research field truly interdisciplinary.

Graph representation learning is a rapidly growing field. It has attracted significant amounts of attention from different domains and consequently accumulated a large body of literature. Thus, it is a propitious time to systematically survey and summarize this field. This book is our diligent attempt to achieve this goal by taking advantage of our teaching and research experience of many years in this field. In particular, we aim to help researchers to acquire essential knowledge of graph representation learning and its wide range of applications and understand its advances and new frontiers.

An Overview of the Book. This book provides a comprehensive introduction to graph representation learning with a focus on deep learning on graphs especially GNNs. It consists of four parts: Foundations, Methods, Applications, and Advances. The Foundations part introduces the necessary background and basic concepts of graphs and deep learning. Topics covered by the Methods part include modern graph embedding, GNNs for both simple and complex graphs, the robustness and scalability issues of GNNs, and deep graph models beyond GNNs. Each of these topics is covered by a chapter with fundamental concepts and technical details on representative algorithms. The Applications part presents GNN applications in the most typical domains including Natural Language Processing, Computer Vision, Data Mining, Biochemistry, and Healthcare. One chapter is used to cover the most representative sub-fields advanced by GNNs for each domain. New emerging methods and application domains are discussed by the Advances part. For each chapter, further reading is included at the end for readers who are interested in more advanced topics and recent trends.

Target Audience. This book is designed to be as self-contained as possible

though the basic background of graph theory, calculus, linear algebra, probability, and statistics can help better understand its technical details. Thus, it is suitable for a wide range of readers with diverse backgrounds and different purposes of reading. This book can serve as both a learning tool and a reference for students at the senior undergraduate or graduate levels who want to obtain a comprehensive understanding of this research field. Researchers who wish to pursue this research field can consider this book as a starting point. Project managers and practitioners can learn from GNNs applications in the book on how to adopt GNNs in their products and platforms. Researchers outside of computer science can find an extensive set of examples from this book on how to apply GNNs to different disciplines.

Yao Ma
Jiliang Tang
East Lansing, MI
August, 2020

1

Deep Learning on Graphs: An Introduction

1.1 Introduction

We start this chapter by answering a few questions about the book. First, we discuss why we should pay attention to deep learning on graphs. In particular, why do we represent real-world data as graphs, why do we want to bridge deep learning with graphs, and what are challenges for deep learning on graphs? Second, we introduce what content this book will cover. Specifically, which topics we will discuss and how we organize these topics? Third, we provide guidance about who should read this book. Especially what is our target audience and how to read this book with different backgrounds and purposes of reading? To better understand deep learning on graphs, we briefly review the history under the more general context of feature learning on graphs.

1.2 Why Deep Learning on Graphs?

Since data from real-world applications have very diverse forms, from matrix and tensor to sequence and time series, a natural question that arises is why we attempt to represent data as graphs. There are two primary motivations. First, graphs provide a universal representation of data. Data from many systems across various areas can be explicitly denoted as graphs such as social networks, transportation networks, protein-protein interaction networks, knowledge graphs, and brain networks. Meanwhile, as indicated by Figure 1.1, numerous other types of data can be transformed into the form of graphs (Xu, 2017). Second, a vast number of real-world problems can be addressed as a small set of computational tasks on graphs. Inferring nodes' attributes, detecting anomalous nodes (e.g., spammers or terrorists), identifying relevant genes to diseases, and suggesting medicines to patients can be sum-

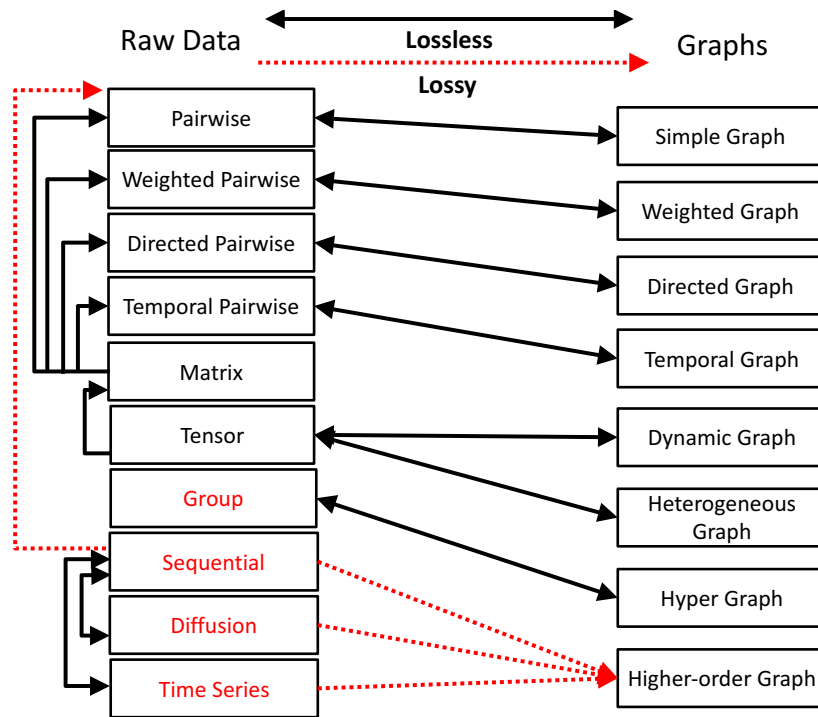

Figure 1.1 Representing real-world data as graphs. The figure is reproduced from (Xu, 2017). Solid lines are utilized to denote lossless representations, while dotted lines are used to indicate lossy representations. Note that we replace “network” in the original figure with “graph”.

marized as the problem of node classification (Bhagat et al., 2011). Recommendations, polypharmacy side effect prediction, drug-target interaction identification, and knowledge graph completion are essentially the problem of link prediction (Liben-Nowell and Kleinberg, 2007).

Nodes on graphs are inherently connected that suggests nodes not independent. However, traditional machine learning techniques often assume that data is independent and identically distributed. Thus, they are not suitable to directly tackle the computational tasks on graphs. There are two main directions to develop solutions. As shown in Figure 1.2, we will use node classification as an illustrative example to discuss these two directions. One direction is to build a new mechanism specific to graphs. The classification problem designed for graphs is known as collective classification (Sen et al., 2008) as demonstrated in Figure 1.2a. Different from traditional classification, for a node, col-

lective classification considers not only the mapping between its features and its label but also the mapping for its neighborhood. The other direction is to flatten a graph by constructing a set of features to denote its nodes where traditional classification techniques can be applied, as illustrated in Figure 1.2b. This direction can take advantage of traditional machine learning techniques; thus, it has become increasingly popular and dominant. The key to the success of this direction is how to construct a set of features for nodes (or node representations). Deep learning has been proven to be powerful in representation learning that has greatly advanced various domains such as computer vision, speech recognition, and natural language processing. Therefore, bridging deep learning with graphs present unprecedented opportunities. However, deep learning on graphs also faces immense challenges. First, traditional deep learning has been designed for regular structured data such as images and sequences, while graphs are irregular where nodes in a graph are unordered and can have distinct neighborhoods. Second, the structural information for regular data is simple; while that for graphs is complicated especially given that there are various types of complex graphs (as shown in Figure 1.1) and nodes and edges can associate with rich side information; thus traditional deep learning is not sufficient to capture such rich information. A new research field has been cultivated – deep learning on graphs, embracing unprecedented opportunities and immense challenges.

1.3 What Content is Covered?

The high-level organization of the book is demonstrated in Figure 1.3. The book consists of four parts to best accommodate our readers with diverse backgrounds and purposes of reading. Part ONE introduces basic concepts; Part TWO discusses the most established methods; Part THREE presents the most typical applications, and Part FOUR describes advances of methods and applications that tend to be important and promising for future research. For each chapter, we first motivate the content that will be covered, then present the material with compelling examples and technical details; and finally, provide more relevant content as further reading. Next, we briefly elaborate on each chapter.

- **Part ONE: Foundations.** These chapters focus on the basics of graphs and deep learning that will lay the foundations for deep learning on graphs. In Chapter 2, we introduce the key concepts and properties of graphs, Graph Fourier Transform, graph signal processing, and formally define various

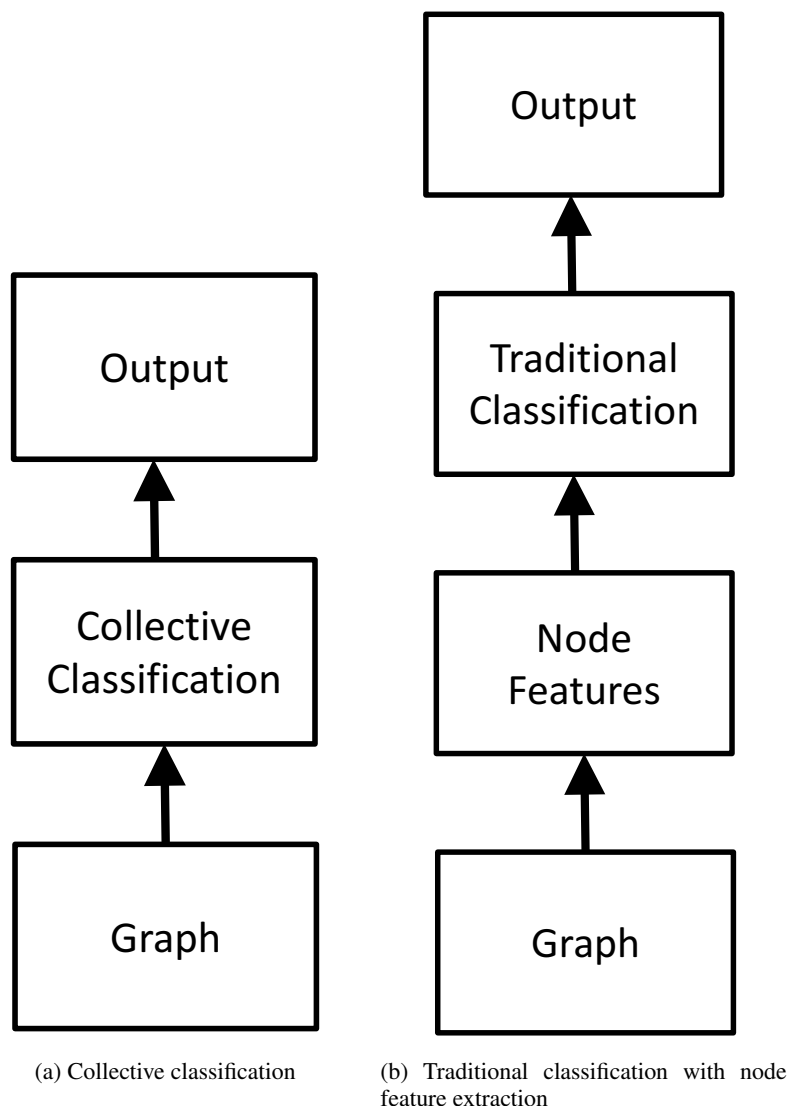

Figure 1.2 Two major directions to develop solutions for node classification on graphs

types of complex graphs and computational tasks on graphs. In Chapter 3, we discuss a variety of basic neural network models, key approaches to train deep models, and practical techniques to prevent overfitting during training.

- Part TWO: Methods. These chapters cover the most established methods

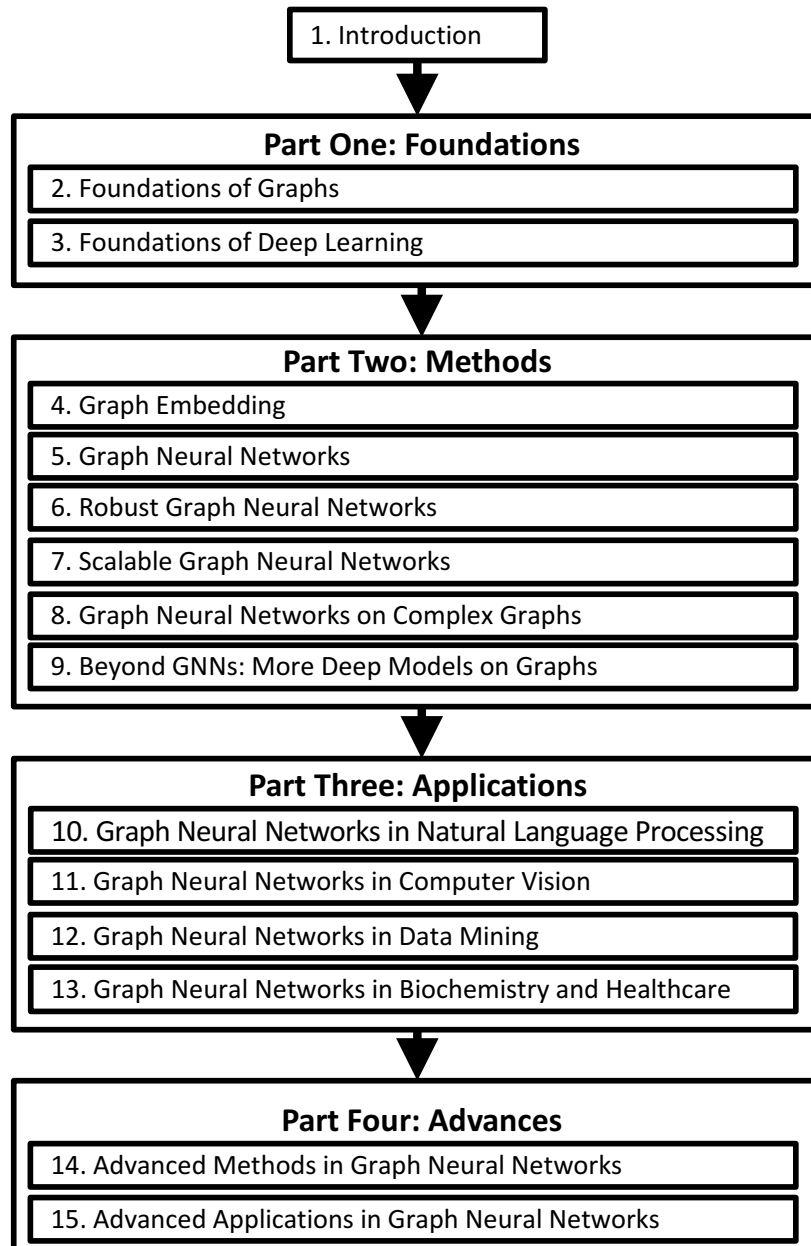

Figure 1.3 The high-level organization of the book

of deep learning on graphs from the basic to advanced settings. In Chapter 4, we introduce a general graph embedding framework from the information preserving perspective, provide technical details on representative algorithms to preserve numerous types of information on graphs and present embedding approaches specifically designed for complex graphs. A typical graph neural network (GNN) model consists of two important operations, i.e., the graph filtering operation and the graph pooling operation. In Chapter 5, we review the state of the art graph filtering and pooling operations and discuss how to learn the parameters of GNNs for a given downstream task. As the generalizations of traditional deep models to graphs, GNNs inherit the drawbacks of traditional deep models and are vulnerable to adversarial attacks. In Chapter 6, we focus on concepts and definitions of graph adversarial attacks and detail representative adversarial attack and defense techniques. GNNs perform the recursive expansion of neighborhoods across layers. The expansion of the neighborhood for a single node can rapidly involve a large portion of the graph or even the whole graph. Hence, scalability is a pressing issue for GNNs. We detail representative techniques to scale GNNs in Chapter 7. In Chapter 8, we discuss GNN models that have been designed for more complicated graphs. To enable deep learning techniques to advance more tasks on graphs under wider settings, we introduce numerous deep graph models beyond GNNs in Chapter 9.

- **Part THREE: Applications.** Graphs provide a universal representation for real-world data; thus, methods of deep learning on graphs have been applied to various fields. These chapters present the most typical applications of GNNs, including Natural Language Processing in Chapter 10, Computer Vision in Chapter 11, Data Mining in Chapter 12 and Biochemistry and Healthcare in Chapter 13.
- **Part FOUR: Advances.** These chapters focus on recent advances in both methods and applications. In Chapter 14, we introduce advanced methods in GNNs such as expressiveness, depth, fairness, interpretability, and self-supervised learning. We discuss more areas that GNNs have been applied to, including Combinatorial Optimization, Physics, and Program Representation in Chapter 15.

1.4 Who Should Read the Book?

This book is easily accessible to readers with a computer science background. Basic knowledge of calculus, linear algebra, probability, and statistics can help understand its technical details in a better manner. This book has a wide range

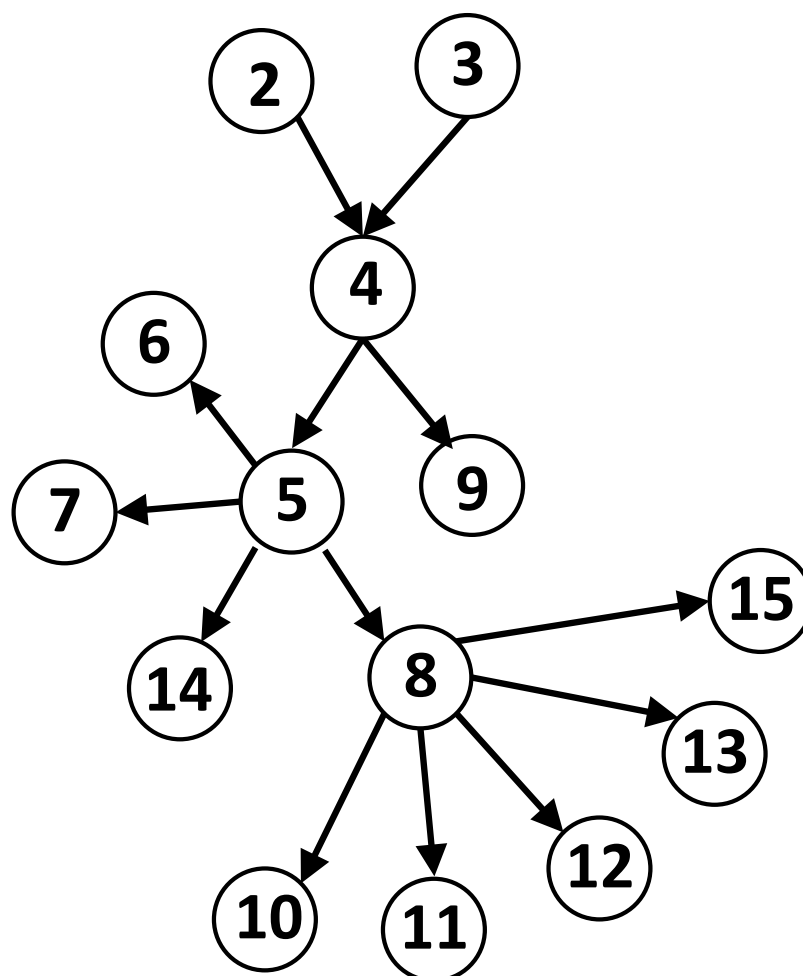

Figure 1.4 The guidance on how to read this book. Note that the number in the circle indicates the corresponding chapter as shown in Figure 1.3.

of target audiences. One target audience is senior undergraduate and graduate students interested in data mining, machine learning, and social network analysis. This book can be independently used for a graduate seminar course on deep learning on graphs. It also can be utilized as a part of a course. For example, Part TWO and Part FOUR can be considered as advanced topics in courses of data mining, machine learning, and social network analysis, and Part THREE can be used as advanced methods in solving traditional tasks

in computer vision, natural language processing, and healthcare. Practitioners and project managers, who want to learn the basics and tangible examples of deep learning on graphs and adopt graph neural networks into their products and platforms, are also our target audience. Graph neural networks have been applied to benefit numerous disciplines beyond computer science. Thus, another target audience is researchers who do not have a computer science background but want to use graph neural networks to advance their disciplines.

Readers with different backgrounds and purposes of reading should go through the book differently. The suggested guidance on how to read this book is demonstrated in Figure 1.4. If readers aim to understand graph neural network methods on simple graphs (or Chapter 5), knowledge about foundations of graphs and deep learning and graph embedding is necessary (or Chapters 2, 3 and 4). Suppose readers want to apply graph neural networks to advance healthcare (or Chapter 13). In that case, they should first read prerequisite materials in foundations of graphs and deep learning, graph embedding and graph neural networks on simple and complex graphs. (or Chapters 2, 3, 4, 5, and 8). For Part THREE, we assume that the readers should have the necessary background in the corresponding application field. Besides, readers should feel free to skip some chapters if they have already been equipped with the corresponding background. Suppose readers know the foundations of graphs and deep learning. In that case, they should skip Chapters 2 and 3 and only read Chapters 4 and 5 to understand GNNs on simple graphs.

1.5 Feature Learning on Graphs: A Brief History

As aforementioned, to take advantage of traditional machine learning for computational tasks on graphs, it is desired to find vector node representations. As shown in Figure 1.5, there are mainly two ways to achieve this goal: feature engineering and feature learning. Feature engineering relies on hand-designed features such as node degree statistics, while feature learning is to learn node features automatically. On the one hand, we often do not have prior knowledge about what features are essential, especially for a given downstream task; thus, features from feature engineering could be suboptimal for the downstream task. The process requires an immense amount of human efforts. On the other hand, feature learning is to learn features automatically, and the downstream task can guide the process. Consequently, the learned features are likely to be suitable for the downstream task that often obtain better performance than those via feature engineering. Meanwhile, the process requires minimal human intervention and can be easily adapted to new tasks. Thus, feature learning on

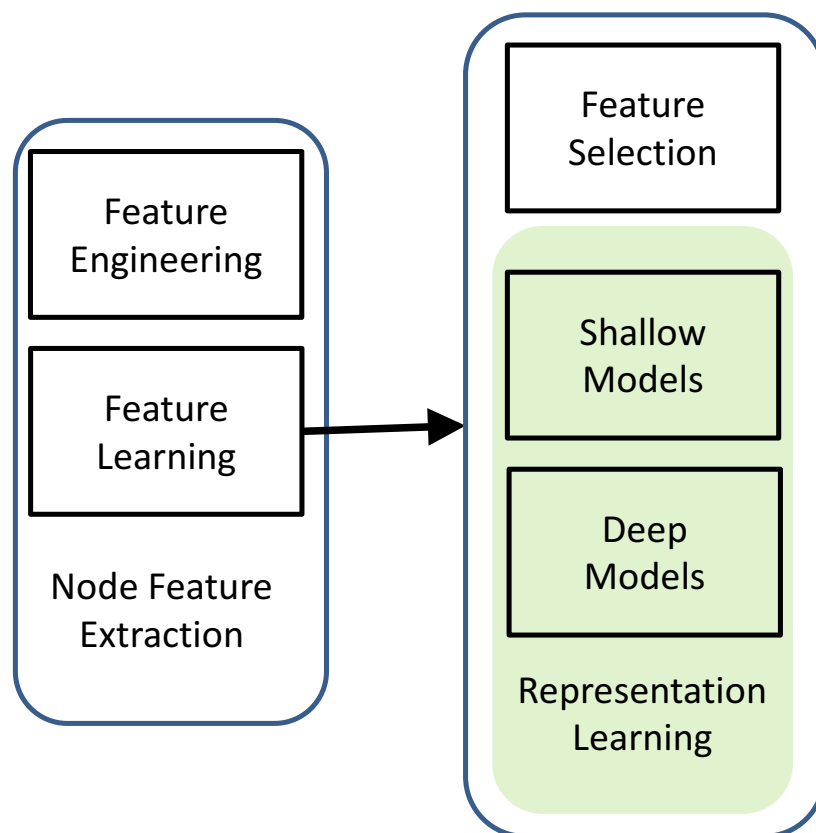

Figure 1.5 Node feature extraction

graphs has been extensively studied, and various types of feature learning techniques have been proposed to meet different requirements and scenarios. We roughly divide these techniques into feature selection on graphs that aims to remove irrelevant and redundant node features and representation learning on graphs that targets on generating a set of new node features. In this section, we briefly review these two groups of techniques that provide a general and historical context for readers to understand deep learning on graphs.

1.5.1 Feature Selection on Graphs

Real-world data is often high-dimensional, and there exist noisy, irrelevant, and redundant features (or dimensions), particularly when considering a given

task. Feature selection aims to automatically select a small subset of features that have minimal redundancy but maximal relevance to the target, such as the class labels under the supervised setting. In many applications, the original features are crucial for knowledge extraction and model interpretation. For example, in genetic analysis for cancer study, in addition to differentiating cancerous tissues, it is of greater importance to identify the genes (i.e., original features) that induce cancerogenesis. In these demanding applications, feature selection is particularly preferred since it maintains the original features, and their semantics usually provide critical insights to the learning problem. Traditional feature selection assumes that data instances are independent and identically distributed (i.i.d.). However, data samples in many applications are embedded in graphs that are inherently not i.i.d.. It has motivated the research area of feature selection on graphs. Given a graph $\mathcal{G} = \{\mathcal{V}, \mathcal{E}\}$ where \mathcal{V} is the node set and \mathcal{E} is the edge set, we assume that each node is originally associated with a set of d features $\mathcal{F} = \{f_1, f_2, \dots, f_d\}$. Feature selection on graphs aims to select K features from \mathcal{F} to denote each node where $K \ll d$. The problem was first investigated under the supervised setting in (Tang and Liu, 2012a; Gu and Han, 2011). A linear classifier is employed to map from the selected features to the class labels, and a graph regularization term is introduced to capture structural information for feature selection. In particular, the term aims to ensure that connected nodes with the selected features can be mapped into similar labels. Then, the problem was further studied under the unsupervised setting (Wei et al., 2016, 2015; Tang and Liu, 2012b). In (Tang and Liu, 2012b), pseudo labels are extracted from the structural information that serve as the supervision to guide the feature selection process. In (Wei et al., 2016), both the node content and structural information are assumed to be generated from a set of high-quality features that can be obtained by maximizing the likelihood of the generation process. Later on, the problem has been extended from simple graphs to complex graphs such as dynamic graphs (Li et al., 2016), multi-dimensional graphs (Tang et al., 2013b), signed graphs (Cheng et al., 2017; Huang et al., 2020) and attributed graphs (Li et al., 2019b).

1.5.2 Representation Learning on Graphs

Different from feature selection on graphs, representation learning on graphs is to learn a set of new node features. It has been extensively studied for decades and has been dramatically accelerated by deep learning. In this subsection, we will give it a brief historical review from shallow models to deep models.

At the early stage, representation learning on graphs has been studied under the context of spectral clustering (Shi and Malik, 2000; Ng et al., 2002),

graph-based dimension reduction (Belkin and Niyogi, 2003; Tenenbaum et al., 2000; Roweis and Saul, 2000), and matrix factorization (Zhu et al., 2007; Tang et al., 2013a; Koren et al., 2009). In spectral clustering (Shi and Malik, 2000; Ng et al., 2002), data points are considered as nodes of a graph, and then clustering is to partition the graph into communities of nodes. One key step for spectral clustering is spectral embedding. It aims to embed nodes into a low-dimensional space where traditional clustering algorithms such as k-means can be applied to identify clusters. Techniques of graph-based dimension reduction can be directly applied to learn node representations. These approaches typically build an affinity graph using a predefined distance (or similarity) function based on the raw features of data samples. They aim to learn node representations to preserve structural information of this affinity graph. For example, IsoMap (Tenenbaum et al., 2000) is to preserve the global geometry via geodesics, while LLE (Roweis and Saul, 2000) and eigenmap (Belkin and Niyogi, 2003) are to preserve local neighborhoods in the affinity graph. The methods mentioned above often need to perform eigendecomposition on the affinity matrix (or adjacency matrix or Laplacian matrix). Thus, they are often computationally expensive. Matrix is one of the most popular approaches to denote graphs such as adjacency matrix, incidence matrix, and Laplacian matrix. As a result, matrix factorization can be naturally applied to learn node representations. Suppose we use the adjacency matrix to denote a graph. In that case, it aims to embed nodes into a low-dimensional space where the new node representations can be utilized to reconstruct the adjacency matrix. A document corpus can be denoted as a bipartite graph where documents and words are nodes, and an edge exists between a word and a document if the word appears in the document. LSI has employed truncated SVD to learn representations of documents and words (Deerwester et al., 1990). In recommender systems, interactions between users and items can be captured as a bipartite graph, and matrix factorization has been employed to learn representations of users and items for recommendations (Koren et al., 2009). Matrix factorization is also leveraged to learn node representations for node classification (Zhu et al., 2007; Tang et al., 2016a), link prediction (Menon and Elkan, 2011; Tang et al., 2013a) and community detection (Wang et al., 2011). A family of modern graph embedding algorithms we will introduce later can also be unified as matrix factorization (Qiu et al., 2018b).

Word2vec is a technique to generate word embeddings (Mikolov et al., 2013). It takes a large corpus of text as input and produces a vector representation for each unique word in the corpus. The huge success of Word2vec in various natural language processing tasks has motivated increasing efforts to apply Word2vec, especially the Skip-gram model to learn node representa-

tions in the graph domain. DeepWalk (Perozzi et al., 2014) takes the first step to achieve this goal. Specifically, nodes in a given graph are treated as words of an artificial language, and sentences in this language are generated by random walks. Then, it uses the Skip-gram model to learn node representations, which preserves the node co-occurrence in these random walks. After that, a large body of works have been developed in three major directions – (1) Developing advanced methods to preserve node co-occurrence (Tang et al., 2015; Grover and Leskovec, 2016; Cao et al., 2015); (2) Preserving other types of information such as node’s structural role (Ribeiro et al., 2017), community information (Wang et al., 2017c) and node status (Ma et al., 2017; Lai et al., 2017; Gu et al., 2018); and (3) Designing frameworks for complex graphs such as directed graphs (Ou et al., 2016), heterogeneous graphs (Chang et al., 2015; Dong et al., 2017), bipartite graphs (Gao et al., 2018b), multi-dimensional graphs (Ma et al., 2018d), signed graphs (Wang et al., 2017b), hyper graphs (Tu et al., 2018), and dynamic graphs (Nguyen et al., 2018; Li et al., 2017a).

Given the power and the success of DNNs in representation learning, increasing efforts have been made to generalize DNNs to graphs. These methods are known as graph neural networks (GNNs) that can be roughly divided into spatial approaches and spectral approaches. Spatial approaches explicitly leverage the graph structure, such as spatially close neighbors, and the first spatial approach was introduced by (Scarselli et al., 2005). Spectral approaches utilize the spectral view of graphs by taking advantage of Graph Fourier Transform and the Inverse Graph Fourier Transform (Bruna et al., 2013). In the era of deep learning, GNNs have been rapidly developed in the following aspects.

- A huge amount of new GNN models have been introduced including spectral approaches (Bruna et al., 2013; Defferrard et al., 2016; Kipf and Welling, 2016a) and spatial approaches (Atwood and Towsley, 2016; Niepert et al., 2016; Gilmer et al., 2017; Monti et al., 2017; Veličković et al., 2017; Hamilton et al., 2017a).
- For graph-focused tasks such as graph classification, the representation of the whole graph is desired. Thus, numerous pooling methods have been introduced to obtain the graph representation from node representations (Li et al., 2015; Ying et al., 2018c; Gao and Ji, 2019; Ma et al., 2019b).
- Traditional DNNs are vulnerable to adversarial attacks. GNNs inherit this drawback. A variety of graph adversarial attacks have been studied (Zügner et al., 2018; Zügner and Günnemann, 2019; Dai et al., 2018; Ma et al., 2020a) and various defense techniques have been developed (Dai et al., 2018; Zhu et al., 2019a; Tang et al., 2019; Jin et al., 2020b).
- As aforementioned, scalability is a pressing issue for GNNs. Many strategies

have been studied to allow GNNs scale to large graphs (Chen et al., 2018a,b; Huang et al., 2018).

- GNN models have been designed to handle complex graphs such as heterogeneous graphs (Zhang et al., 2018b; Wang et al., 2019i; Chen et al., 2019b), bipartite graphs (He et al., 2019), multi-dimensional graphs (Ma et al., 2019c), signed graphs (Derr et al., 2018), hypergraphs (Feng et al., 2019b; Yadati et al., 2019), and dynamic graphs (Pareja et al., 2019).
- Diverse deep architectures have been generalized to graphs such as autoencoder (Wang et al., 2016; Cao et al., 2016), variational autoencoder (Kipf and Welling, 2016b), recurrent neural networks (Tai et al., 2015; Liang et al., 2016) and generative adversarial networks (Wang et al., 2018a).
- As graphs are a universal data representation, GNNs have been applied to advance many fields such as natural language processing, computer vision, data mining, and healthcare.

1.6 Conclusion

In this chapter, we discussed the opportunities and challenges when we bridge deep learning with graphs that have motivated the focus of this book – deep learning on graphs. The book will cover the essential topics of deep learning on graphs that are organized into four parts to accommodate readers with diverse backgrounds and purposes of reading, including foundations, methods, applications, and advances. This book can benefit a broader range of readers, including senior undergraduate students, graduate students, practitioners, project managers, and researchers from various disciplines. To provide more context for readers, we give a brief historical review on the area of feature learning on graphs.

1.7 Further Reading

In this chapter, we have briefly reviewed the history of feature selection on graphs. If readers want to know more about feature selection, there are several important books (Liu and Motoda, 2012, 2007) and comprehensive surveys (Tang et al., 2014a). An open-source feature selection repository named *scikit-feature* has been developed, consisting of most of the popular feature selection algorithms (Li et al., 2017b). Though this is the first comprehensive book on the topic of deep learning on graphs, there are books on the general

topics on deep learning (Goodfellow et al., 2016; Aggarwal, 2018), deep learning on speech recognition (Yu and Deng, 2016; Kamath et al., 2019), and deep learning in natural language processing (Deng and Liu, 2018; Kamath et al., 2019).

PART ONE

FOUNDATIONS

2

Foundations of Graphs

2.1 Introduction

Graphs, which describe pairwise relations between entities, are essential representations for real-world data from many different domains, including social science, linguistics, chemistry, biology, and physics. Graphs are widely utilized in social science to indicate the relations between individuals. In chemistry, chemical compounds are denoted as graphs with atoms as nodes and chemical bonds as edges (Bonchev, 1991). In linguistics, graphs are utilized to capture the syntax and compositional structures of sentences. For example, parsing trees are leveraged to represent the syntactic structure of a sentence according to some context-free grammar, while Abstract Meaning Representation (AMR) encodes the meaning of a sentence as a rooted and directed graph (Banarescu et al., 2013). Hence, research on graphs has attracted immense attention from multiple disciplines. In this chapter, we first introduce basic concepts of graphs and discuss the matrix representations of graphs, including adjacency matrix and Laplacian matrix (Chung and Graham, 1997) and their fundamental properties. Then we introduce attributed graphs where each node is associated with attributes and provide a new understanding of these graphs by regarding the attributes as functions or signals on the graph (Shuman et al., 2013). We present the concepts of graph Fourier analysis and graph signal processing, which lay essential foundations for deep learning on graphs. Next, we describe various complex graphs that are frequently utilized to capture complicated relations among entities in real-world applications. Finally, we discuss representative computational tasks on graphs that have been broadly served as downstream tasks for deep learning on graphs.

2.2 Graph Representations

In this section, we introduce the definition of graphs. We focus on simple unweighted graphs and will discuss more complex graphs in the following sections.

Definition 2.1 (Graph) A graph can be denoted as $\mathcal{G} = \{\mathcal{V}, \mathcal{E}\}$, where $\mathcal{V} = \{v_1, \dots, v_N\}$ is a set of $N = |\mathcal{V}|$ nodes and $\mathcal{E} = \{e_1, \dots, e_M\}$ is a set of M edges.

Nodes are essential entities in a graph. In social graphs, users are viewed as nodes, while in chemical compound graphs, chemical atoms are treated as nodes. The size of a given graph \mathcal{G} is defined by its number of nodes, i.e., $N = |\mathcal{V}|$. The set of edges \mathcal{E} describes the connections between nodes. An edge $e \in \mathcal{E}$ connects two nodes v_e^1 and v_e^2 ; thus, the edge e can be also represented as (v_e^1, v_e^2) . In directed graphs, the edge is directed from node v_e^1 to node v_e^2 . While in undirected graphs, the order of the two nodes does not make a difference, i.e., $e = (v_e^1, v_e^2) = (v_e^2, v_e^1)$. Note that without specific mention, we limit our discussion to undirected graphs in this chapter. The nodes v_e^1 and v_e^2 are incident to the edge e . A node v_i is adjacent to another node v_j if and only if there exists an edge between them. In social graphs, different relations such as friendship can be viewed as edges between nodes, and chemical bonds are considered as edges in chemical compound graphs (we regard all chemical bonds as edges while ignoring their different types). A graph $\mathcal{G} = \{\mathcal{V}, \mathcal{E}\}$ can be equivalently represented as an adjacency matrix, which describes the connectivity between the nodes.

Definition 2.2 (Adjacency Matrix) For a given graph $\mathcal{G} = \{\mathcal{V}, \mathcal{E}\}$, the corresponding adjacency matrix is denoted as $\mathbf{A} \in \{0, 1\}^{N \times N}$. The i, j -th entry of the adjacency matrix \mathbf{A} , indicated as $\mathbf{A}_{i,j}$, represents the connectivity between two nodes v_i and v_j . More specifically, $\mathbf{A}_{i,j} = 1$ if v_i is adjacent to v_j , otherwise $\mathbf{A}_{i,j} = 0$.

In an undirected graph, a node v_i is adjacent to v_j , if and only if v_j is adjacent to v_i , thus $\mathbf{A}_{i,j} = \mathbf{A}_{j,i}$ holds for all v_i and v_j in the graph. Hence, for an undirected graph, its corresponding adjacency matrix is symmetric.

Example 2.3 An illustrative graph with 5 nodes and 6 edges is shown in Figure 2.1. In this graph, the set of nodes is represented as $\mathcal{V} = \{v_1, v_2, v_3, v_4, v_5\}$, and the set of edges is $\mathcal{E} = \{e_1, e_2, e_3, e_4, e_5, e_6\}$. Its adjacency matrix can be denoted as follows:

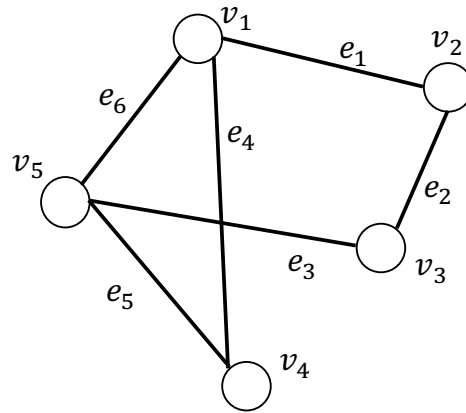

Figure 2.1 A graph with 5 nodes and 6 edges

$$\mathbf{A} = \begin{pmatrix} 0 & 1 & 0 & 1 & 1 \\ 1 & 0 & 1 & 0 & 0 \\ 0 & 1 & 0 & 0 & 1 \\ 1 & 0 & 0 & 0 & 1 \\ 1 & 0 & 1 & 1 & 0 \end{pmatrix}$$

2.3 Properties and Measures

Graphs can have varied structures and properties. In this section, we discuss basic properties and measures for graphs.

2.3.1 Degree

The degree of a node v in a graph \mathcal{G} indicates the number of times that a node is adjacent to other nodes. We have the following formal definition.

Definition 2.4 (Degree) In a graph $\mathcal{G} = \{\mathcal{V}, \mathcal{E}\}$, the degree of a node $v_i \in \mathcal{V}$ is the number of nodes that are adjacent to v_i .

$$d(v_i) = \sum_{v_j \in \mathcal{V}} \mathbb{1}_{\mathcal{E}}(\{v_i, v_j\}),$$

where $\mathbb{1}_{\mathcal{E}}(\cdot)$ is an indicator function:

$$\mathbb{1}_{\mathcal{E}}(\{v_i, v_j\}) = \begin{cases} 1 & \text{if } (v_i, v_j) \in \mathcal{E}, \\ 0 & \text{if } (v_i, v_j) \notin \mathcal{E}. \end{cases}$$

The degree of a node v_i in \mathcal{G} can also be calculated from its adjacency matrix. More specifically, for a node v_i , its degree can be computed as:

$$d(v_i) = \sum_{j=1}^N \mathbf{A}_{i,j}. \quad (2.1)$$

Example 2.5 In the graph shown in Figure 2.1, the degree of node v_5 is 3, as it is adjacent to 3 other nodes (i.e., v_1 , v_3 and v_4). Furthermore, the 5-th row of the adjacency matrix has 3 non-zero elements, which also indicates that the degree of v_5 is 3.

Definition 2.6 (Neighbors) For a node v_i in a graph $\mathcal{G} = \{\mathcal{V}, \mathcal{E}\}$, the set of its neighbors $\mathcal{N}(v_i)$ consists of all nodes that are adjacent to v_i .

Note that for a node v_i , the number of nodes in $\mathcal{N}(v_i)$ equals to its degree, i.e., $d(v_i) = |\mathcal{N}(v_i)|$.

Theorem 2.7 For a graph $\mathcal{G} = \{\mathcal{V}, \mathcal{E}\}$, its total degree, i.e., the summation of the degree of all nodes, is twice the number of edges in the graph.

$$\sum_{v_i \in \mathcal{V}} d(v_i) = 2 \cdot |\mathcal{E}|.$$

Proof

$$\begin{aligned} \sum_{v_i \in \mathcal{V}} d(v_i) &= \sum_{v_i \in \mathcal{V}} \sum_{v_j \in \mathcal{V}} \mathbb{1}_{\mathcal{E}}(\{v_i, v_j\}) \\ &= \sum_{\{v_i, v_j\} \in \mathcal{E}} 2 \cdot \mathbb{1}_{\mathcal{E}}(\{v_i, v_j\}) \\ &= 2 \cdot \sum_{\{v_i, v_j\} \in \mathcal{E}} \mathbb{1}_{\mathcal{E}}(\{v_i, v_j\}) \\ &= 2 \cdot |\mathcal{E}| \end{aligned}$$

□

Corollary 2.8 The number of non-zero elements in the adjacency matrix is also twice the number of the edges.

Proof The proof follows Theorem 2.7 by using Eq. (2.1). □

Example 2.9 For the graph shown in Figure 2.1, the number of edges is 6. The total degree is 12 and the number of non-zero elements in its adjacent matrix is also 12.

2.3.2 Connectivity

Connectivity is an important property of graphs. Before discussing connectivity in graphs, we first introduce some basic concepts such as walk and path.

Definition 2.10 (Walk) A walk on a graph is an alternating sequence of nodes and edges, starting with a node and ending with a node where each edge is incident with the nodes immediately preceding and following it.

A walk starting at node u and ending at node v is called a u - v walk. The length of a walk is the number of edges in this walk. Note that u - v walks are not unique since there exist various u - v walks with different lengths.

Definition 2.11 (Trail) A trail is a walk whose edges are distinct.

Definition 2.12 (Path) A path is a walk whose nodes are distinct.

Example 2.13 In the graph shown in Figure 2.1, $(v_1, e_4, v_4, e_5, v_5, e_6, v_1, e_1, v_2)$ is a v_1 - v_2 walk of length 4. It is a trail but not a path as it visits node v_1 twice. Meanwhile, $(v_1, e_1, v_2, e_2, v_3)$ is a v_1 - v_3 walk. It is a trail as well as a path.

Theorem 2.14 For a graph $\mathcal{G} = \{\mathcal{E}, \mathcal{V}\}$ with the adjacency matrix \mathbf{A} , we use \mathbf{A}^n to denote the n -th power of the adjacency matrix. The i, j -th element of the matrix \mathbf{A}^n equals to the number of v_i - v_j walks of length n .

Proof We can prove this theorem by induction. For $n = 1$, according to the definition of the adjacency matrix, when $\mathbf{A}_{i,j} = 1$, there is an edge between nodes v_i and v_j , which is regarded as a v_i - v_j walk of length 1. When $\mathbf{A}_{i,j} = 0$, there is no edge between v_i and v_j , thus there is no v_i - v_j walk of length 1. Hence, the theorem holds for $n = 1$. Assume that the theorem holds when $n = k$. In other words, the i, h -th element of \mathbf{A}^k equals to the number of v_i - v_h walks of length k . We then proceed to prove the case when $n = k + 1$. Specifically, the i, j -th element of \mathbf{A}^{k+1} can be calculated by using \mathbf{A}^k and \mathbf{A} as

$$\mathbf{A}_{i,j}^{k+1} = \sum_{h=1}^N \mathbf{A}_{i,h}^k \cdot \mathbf{A}_{h,j}. \quad (2.2)$$

For each h in Eq. (2.2), the term $\mathbf{A}_{i,h}^k \cdot \mathbf{A}_{h,j}$ is non-zero only if both $\mathbf{A}_{i,h}^k$ and $\mathbf{A}_{h,j}$ are non-zero. We have already known that $\mathbf{A}_{i,h}^k$ denotes the number of v_i - v_h walks of length k while $\mathbf{A}_{h,j}$ indicates the number of the v_h - v_j walk of length 1.

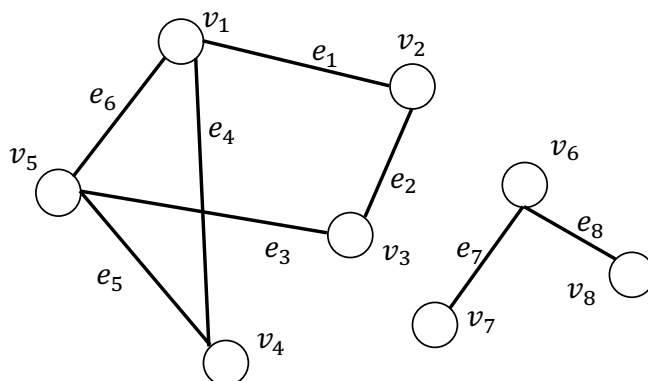

Figure 2.2 A graph with two connected components

Hence, the term $\mathbf{A}_{i,h}^k \cdot \mathbf{A}_{h,j}$ counts the number of v_i - v_j walks of length $k + 1$ with v_h as the second last node in the walk. Thus, when summing over all possible nodes v_h , the i, j -th element of \mathbf{A}^{k+1} equals to the number of v_i - v_j walks of length $k + 1$, which completes the proof. \square

Definition 2.15 (Subgraph) A subgraph $\mathcal{G}' = \{\mathcal{V}', \mathcal{E}'\}$ of a given graph $\mathcal{G} = \{\mathcal{V}, \mathcal{E}\}$ is a graph formed with a subset of nodes $\mathcal{V}' \subset \mathcal{V}$ and a subset of edges $\mathcal{E}' \subset \mathcal{E}$. Furthermore, the subset \mathcal{V}' must contain all the nodes involved in the edges in the subset \mathcal{E}' .

Example 2.16 For the graph shown in Figure 2.1, the subset of nodes $\mathcal{V}' = \{v_1, v_2, v_3, v_5\}$ and the subset of edges $\mathcal{E}' = \{e_1, e_2, e_3, e_6\}$ form a subgraph of the original graph \mathcal{G} .

Definition 2.17 (Connected Component) Given a graph $\mathcal{G} = \{\mathcal{V}, \mathcal{E}\}$, a subgraph $\mathcal{G}' = \{\mathcal{V}', \mathcal{E}'\}$ is said to be a connected component if there is at least one path between any pair of nodes in the graph and the nodes in \mathcal{V}' are not adjacent to any vertices in \mathcal{V}/\mathcal{V}' .

Example 2.18 A graph with two connected components is shown in Figure 2.2, where the left and right connected components are not connected to each other.

Definition 2.19 (Connected Graph) A graph $\mathcal{G} = \{\mathcal{V}, \mathcal{E}\}$ is said to be connected if it has exactly one component.

Example 2.20 The graph shown in Figure 2.1 is a connected graph, while the graph in Figure 2.2 is not a connected graph.

Given a pair of nodes in a graph, there may exist multiple paths with different lengths between them. For example, there are 3 paths from node v_5 to node v_2 in the graph shown in Figure 2.1: $(v_5, e_6, v_1, e_1, v_2)$, $(v_5, e_5, v_4, e_4, v_1, e_1, v_2)$ and $(v_5, e_3, v_3, e_2, v_2)$. Among them, $(v_5, e_6, v_1, e_1, v_2)$ and $(v_5, e_3, v_3, e_2, v_2)$ with length 2 are the shortest paths from v_5 to v_2 .

Definition 2.21 (Shortest Path) Given a pair of nodes $v_s, v_t \in \mathcal{V}$ in graph \mathcal{G} , we denote the set of paths from node v_s to node v_t as \mathcal{P}_{st} . The shortest path between node v_s and node v_t is defined as:

$$p_{st}^{sp} = \arg \min_{p \in \mathcal{P}_{st}} |p|,$$

where p denotes a path in \mathcal{P}_{st} with $|p|$ its length and p_{st}^{sp} indicates the shortest path. Note that there could be more than one shortest path between any given pair of nodes.

The shortest path between a pair of nodes describes important information between them. A collective information of the shortest paths between any pairs of nodes in a graph indicates important characteristics of the graph. Specifically, the diameter of a graph is defined as the length of the longest shortest path in the graph.

Definition 2.22 (Diameter) Given a connected graph $\mathcal{G} = \{\mathcal{V}, \mathcal{E}\}$, its diameter is defined as follows:

$$\text{diameter}(\mathcal{G}) = \max_{v_s, v_t \in \mathcal{V}} \min_{p \in \mathcal{P}_{st}} |p|.$$

Example 2.23 For the connected graph shown in Figure 2.1, its diameter is 2. One of the longest shortest paths are between node v_2 and node v_4 denoted as $(v_2, e_1, v_1, e_4, v_4)$.

2.3.3 Centrality

In a graph, the centrality of a node measures the importance of the node in the graph. There are different ways to measure node importance. In this section, we introduce various definitions of centrality.

Degree Centrality

Intuitively, a node can be considered as important if there are many other nodes connected to it. Hence, we can measure the centrality of a given node based on its degree. In particular, for node v_i , its degree centrality can be defined as

follows:

$$c_d(v_i) = d(v_i) = \sum_{j=1}^N \mathbf{A}_{i,j}.$$

Example 2.24 For the graph shown in Figure 2.1, the degree centrality for nodes v_1 and v_5 is 3, while the degree centrality for nodes v_2 , v_3 and v_4 is 2.

Eigenvector Centrality

While the degree based centrality considers a node with many neighbors as important, it treats all the neighbors equally. However, the neighbors themselves can have different importance; thus they could affect the importance of the central node differently. The eigenvector centrality (Bonacich, 1972, 2007) defines the centrality score of a given node v_i by considering the centrality scores of its neighboring nodes as:

$$c_e(v_i) = \frac{1}{\lambda} \sum_{j=1}^N \mathbf{A}_{i,j} \cdot c_e(v_j),$$

which can be rewritten in a matrix form as:

$$\mathbf{c}_e = \frac{1}{\lambda} \mathbf{A} \cdot \mathbf{c}_e, \quad (2.3)$$

where $\mathbf{c}_e \in \mathbb{R}^N$ is a vector containing the centrality scores of all nodes in the graph. We can reform Eq. (2.3) as:

$$\lambda \cdot \mathbf{c}_e = \mathbf{A} \cdot \mathbf{c}_e.$$

Clearly, \mathbf{c}_e is an eigenvector of the matrix \mathbf{A} with its corresponding eigenvalue λ . However, given an adjacency matrix \mathbf{A} , there exist multiple pairs of eigenvectors and eigenvalues. Usually, we want the centrality scores to be positive. Hence, we wish to choose an eigenvector with all positive elements. According to Perron–Frobenius theorem (Perron, 1907; Frobenius et al., 1912; Pillai et al., 2005), a real squared matrix with positive elements has a unique largest eigenvalue and its corresponding eigenvector has all positive elements. Thus, we can choose λ as the largest eigenvalue and its corresponding eigenvector as the centrality score vector.

Example 2.25 For the graph shown in Figure 2.1, its largest eigenvalue is 2.481 and its corresponding eigenvector is $[1, 0.675, 0.675, 0.806, 1]$. Hence, the eigenvector centrality scores for the nodes v_1, v_2, v_3, v_4, v_5 are 1, 0.675, 0.675, 0.806, and 1, respectively. Note that the degrees of nodes v_2, v_3 and v_4 are 2; however, the eigenvector centrality of node v_4 is higher than that of the other

two nodes as it directly connects to nodes v_1 and v_5 whose eigenvector centrality is high.

Katz Centrality

The Katz centrality is a variant of the eigenvector centrality, which not only considers the centrality scores of the neighbors but also includes a small constant for the central node itself. Specifically, the Katz centrality for a node v_i can be defined as:

$$c_k(v_i) = \alpha \sum_{j=1}^N \mathbf{A}_{i,j} c_k(v_j) + \beta, \quad (2.4)$$

where β is a constant. The Katz centrality scores for all nodes can be expressed in the matrix form as:

$$\begin{aligned} \mathbf{c}_k &= \alpha \mathbf{A} \mathbf{c}_k + \boldsymbol{\beta} \\ (\mathbf{I} - \alpha \cdot \mathbf{A}) \mathbf{c}_k &= \boldsymbol{\beta} \end{aligned} \quad (2.5)$$

where $\mathbf{c}_k \in \mathbb{R}^N$ denotes the Katz centrality score vector for all nodes while $\boldsymbol{\beta}$ is the vector containing the constant term β for all nodes. Note that the Katz centrality is equivalent to the eigenvector centrality if we set $\alpha = \frac{1}{\lambda_{max}}$ and $\beta = 0$, with λ_{max} the largest eigenvalue of the adjacency matrix \mathbf{A} . The choice of α is important – a large α may make the matrix $\mathbf{I} - \alpha \cdot \mathbf{A}$ ill-conditioned while a small α may make the centrality scores useless since it will assign very similar scores close to β to all nodes. In practice, $\alpha < \frac{1}{\lambda_{max}}$ is often selected, which ensures that the matrix $\mathbf{I} - \alpha \cdot \mathbf{A}$ is invertible and \mathbf{c}_k can be calculated as:

$$\mathbf{c}_k = (\mathbf{I} - \alpha \cdot \mathbf{A})^{-1} \boldsymbol{\beta}.$$

Example 2.26 For the graph shown in Figure 2.1, if we set $\beta = 1$ and $\alpha = \frac{1}{5}$, the Katz centrality score for nodes v_1 and v_5 is 2.16, for nodes v_2 and v_3 is 1.79 and for node v_4 is 1.87.

Betweenness Centrality

The aforementioned centrality scores are based on connections to neighboring nodes. Another way to measure the importance of a node is to check whether it is at an important position in the graph. Specifically, if there are many paths passing through a node, it is at an important position in the graph. Formally, we define the betweenness centrality score for a node v_i as:

$$c_b(v_i) = \sum_{v_s \neq v_i \neq v_t} \frac{\sigma_{st}(v_i)}{\sigma_{st}}, \quad (2.6)$$

where σ_{st} denotes the total number of shortest paths from node v_s to node v_t while $\sigma_{st}(v_i)$ indicates the number of these paths passing through the node v_i . As suggested by Eq. (2.6), we need to compute the summation over all possible pairs of nodes for the betweenness centrality score. Therefore, the magnitude of the betweenness centrality score scales as the size of graph scales. Hence, to make the betweenness centrality score comparable across different graphs, we need to normalize it. One effective way is to divide the betweenness score by the largest possible betweenness centrality score given a graph. In Eq. (2.6), the maximum of the betweenness score can be reached when all the shortest paths between any pair of nodes passing through the node v_i . That is $\frac{\sigma_{st}(v_i)}{\sigma_{st}} = 1, \forall v_s \neq v_i \neq v_t$. There are, in total, $\frac{(N-1)(N-2)}{2}$ pairs of nodes in an undirected graph. Hence, the maximum betweenness centrality score is $\frac{(N-1)(N-2)}{2}$. We then define the normalized betweenness centrality score $c_{nb}(v_i)$ for the node v_i as:

$$c_{nb}(v_i) = \frac{2 \sum_{v_s \neq v_i \neq v_t} \frac{\sigma_{st}(v_i)}{\sigma_{st}}}{(N-1)(N-2)},$$

Example 2.27 For the graph shown in Figure 2.1, the betweenness centrality score for nodes v_1 and v_5 is $\frac{3}{2}$, and their normalized betweenness score is $\frac{1}{4}$. The betweenness centrality score for nodes v_2 and v_3 is $\frac{1}{2}$, and their normalized betweenness score is $\frac{1}{12}$. The betweenness centrality score for node v_4 is 0 and its normalized score is also 0.

2.4 Spectral Graph Theory

Spectral graph theory studies the properties of a graph through analyzing the eigenvalues and eigenvectors of its Laplacian matrix. In this section, we introduce the Laplacian matrix of a graph and then discuss its key properties, eigenvalues, and eigenvectors.

2.4.1 Laplacian Matrix

In this subsection, we introduce the Laplacian matrix of a graph, which is another matrix representation for graphs in addition to the adjacency matrix.

Definition 2.28 (Laplacian Matrix) For a given graph $\mathcal{G} = \{\mathcal{V}, \mathcal{E}\}$ with \mathbf{A} as its adjacency matrix, its Laplacian matrix is defined as:

$$\mathbf{L} = \mathbf{D} - \mathbf{A}, \tag{2.7}$$

where \mathbf{D} is a diagonal degree matrix $\mathbf{D} = \text{diag}(d(v_1), \dots, d(v_N))$.

Another definition of the Laplacian matrix is a normalized version of Eq. (2.7).

Definition 2.29 (Normalized Laplacian Matrix) For a given graph $\mathcal{G} = \{\mathcal{V}, \mathcal{E}\}$ with \mathbf{A} as its adjacency matrix, its normalized Laplacian matrix is defined as:

$$\mathbf{L} = \mathbf{D}^{-\frac{1}{2}}(\mathbf{D} - \mathbf{A})\mathbf{D}^{-\frac{1}{2}} = \mathbf{I} - \mathbf{D}^{-\frac{1}{2}}\mathbf{A}\mathbf{D}^{-\frac{1}{2}}. \quad (2.8)$$

Next, we focus on the discussion of the unnormalized Laplacian matrix as defined in Definition 2.28. However, in some later chapters of this book, the normalized Laplacian matrix will also be utilized. Unless specific mention, we refer Laplacian matrix as the unnormalized one defined in Definition 2.28.

Note that the Laplacian matrix is symmetric as both the degree matrix \mathbf{D} and the adjacency matrix \mathbf{A} are symmetric. Let \mathbf{f} denote a vector where its i -th element $\mathbf{f}[i]$ is associated with node v_i . Multiplying \mathbf{L} with \mathbf{f} , we can get a new vector \mathbf{h} as:

$$\begin{aligned} \mathbf{h} &= \mathbf{L}\mathbf{f} \\ &= (\mathbf{D} - \mathbf{A})\mathbf{f} \\ &= \mathbf{D}\mathbf{f} - \mathbf{A}\mathbf{f}. \end{aligned}$$

The i -th element of \mathbf{h} can be represented as:

$$\begin{aligned} \mathbf{h}[i] &= d(v_i) \cdot \mathbf{f}[i] - \sum_{j=1}^N \mathbf{A}_{i,j} \cdot \mathbf{f}[j] \\ &= d(v_i) \cdot \mathbf{f}[i] - \sum_{v_j \in \mathcal{N}(v_i)} \mathbf{A}_{i,j} \cdot \mathbf{f}[j] \\ &= \sum_{v_j \in \mathcal{N}(v_i)} (\mathbf{f}[i] - \mathbf{f}[j]). \end{aligned} \quad (2.9)$$

As informed by Eq. (2.9), $\mathbf{h}[i]$ is the summation of the differences between node v_i and its neighbors $\mathcal{N}(v_i)$. We next calculate $\mathbf{f}^T \mathbf{L}\mathbf{f}$ as below:

$$\begin{aligned} \mathbf{f}^T \mathbf{L}\mathbf{f} &= \sum_{v_i \in \mathcal{V}} \mathbf{f}[i] \sum_{v_j \in \mathcal{N}(v_i)} (\mathbf{f}[i] - \mathbf{f}[j]) \\ &= \sum_{v_i \in \mathcal{V}} \sum_{v_j \in \mathcal{N}(v_i)} (\mathbf{f}[i] \cdot \mathbf{f}[i] - \mathbf{f}[i] \cdot \mathbf{f}[j]) \\ &= \sum_{v_i \in \mathcal{V}} \sum_{v_j \in \mathcal{N}(v_i)} \left(\frac{1}{2} \mathbf{f}[i] \cdot \mathbf{f}[i] - \mathbf{f}[i] \cdot \mathbf{f}[j] + \frac{1}{2} \mathbf{f}[j] \cdot \mathbf{f}[j] \right) \\ &= \frac{1}{2} \sum_{v_i \in \mathcal{V}} \sum_{v_j \in \mathcal{N}(v_i)} (\mathbf{f}[i] - \mathbf{f}[j])^2. \end{aligned} \quad (2.10)$$

Thus, $\mathbf{f}^T \mathbf{L}\mathbf{f}$ is the sum of the squares of the differences between adjacent nodes.

In other words, it measures how different the values of adjacent nodes are. It is easy to verify that $\mathbf{f}^T \mathbf{L} \mathbf{f}$ is always non-negative for any possible choice of a real vector \mathbf{f} , which indicates that the Laplacian matrix is positive semi-definite.

2.4.2 The Eigenvalues and Eigenvectors of the Laplacian Matrix

In this subsection, we discuss main properties of eigenvalues and eigenvectors of the Laplacian matrix.

Theorem 2.30 *For a graph $\mathcal{G} = (\mathcal{V}, \mathcal{E})$, the eigenvalues of its Laplacian matrix \mathbf{L} are non-negative.*

Proof Suppose that λ is an eigenvalue of the Laplacian matrix \mathbf{L} and \mathbf{u} is the corresponding normalized eigenvector. According to the definition of eigenvalues and eigenvectors, we have $\lambda \mathbf{u} = \mathbf{L} \mathbf{u}$. Note that \mathbf{u} is a unit non-zero vector and we have $\mathbf{u}^T \mathbf{u} = 1$. Then,

$$\lambda = \lambda \mathbf{u}^T \mathbf{u} = \mathbf{u}^T \lambda \mathbf{u} = \mathbf{u}^T \mathbf{L} \mathbf{u} \geq 0$$

□

For a graph \mathcal{G} with N nodes, there are, in total, N eigenvalues/eigenvectors (with multiplicity). According to Theorem 2.30, all the eigenvalues are non-negative. Furthermore, there always exists an eigenvalue that equals to 0. Let us consider the vector $\mathbf{u}_1 = \frac{1}{\sqrt{N}}(1, \dots, 1)$. Using Eq. (2.9), we can easily verify that $\mathbf{L} \mathbf{u}_1 = \mathbf{0} = \mathbf{0} \mathbf{u}_1$, which indicates that \mathbf{u}_1 is an eigenvector corresponding to the eigenvalue 0. For convenience, we arrange these eigenvalues in non-decreasing order as $0 = \lambda_1 \leq \lambda_2 \leq \dots \leq \lambda_N$. The corresponding normalized eigenvectors are denoted as $\mathbf{u}_1, \dots, \mathbf{u}_N$.

Theorem 2.31 *Given a graph \mathcal{G} , the number of 0 eigenvalues of its Laplacian matrix \mathbf{L} (the multiplicity of the 0 eigenvalue) equals to the number of connected components in the graph.*

Proof Suppose that there are K connected components in the graph \mathcal{G} . We can partition the set of nodes \mathcal{V} into K disjoint subsets $\mathcal{V}_1, \dots, \mathcal{V}_K$. We first show that there exist at least K orthogonal eigenvectors corresponding to the eigenvalue 0. Construct K vectors $\mathbf{u}_1, \dots, \mathbf{u}_K$ such that $\mathbf{u}_i[j] = \frac{1}{\sqrt{|\mathcal{V}_i|}}$ if $v_j \in \mathcal{V}_i$ and 0 otherwise. We have that $\mathbf{L} \mathbf{u}_i = \mathbf{0}$ for $i = 1, \dots, K$, which indicates that all the K vectors are the eigenvectors of \mathbf{L} corresponding to eigenvalue 0. Furthermore, it is easy to validate that $\mathbf{u}_i^T \mathbf{u}_j = 0$ if $i \neq j$, which means that these K eigenvectors are orthogonal to each other. Hence, the multiplicity of the 0 eigenvalue is at least K . We next show that there are at most K orthogonal

eigenvectors corresponding to the eigenvalue 0. Assume that there exists another eigenvector \mathbf{u}^* corresponding to the eigenvalue 0, which is orthogonal to all the K aforementioned eigenvectors. As \mathbf{u}^* is non-zero, there must exist an element in \mathbf{u}^* that is non-zero. Let us assume that the element is $\mathbf{u}^*[d]$ associated with node $v_d \in \mathcal{V}_i$. Furthermore, according to Eq.(2.10), we have

$$\mathbf{u}^{*T} \mathbf{L} \mathbf{u}^* = \frac{1}{2} \sum_{v_i \in \mathcal{V}} \sum_{v_j \in \mathcal{N}(v_i)} (\mathbf{u}^*[i] - \mathbf{u}^*[j])^2.$$

To ensure $\mathbf{u}^{*T} \mathbf{L} \mathbf{u}^* = 0$, the values of nodes in the same component must be the same. It indicates that all nodes in \mathcal{V}_i have the same value $\mathbf{u}^*[d]$ as node v_d . Hence, $\mathbf{u}_i^T \mathbf{u}^* > 0$. It means \mathbf{u}^* is not orthogonal to \mathbf{u}_i , which leads to a contradiction. Therefore, there is no more eigenvector corresponding to the eigenvalue 0 beyond the K vectors we have constructed. \square

2.5 Graph Signal Processing

In many real-world graphs, there are often features or attributes associated with nodes. This kind of graph-structured data can be treated as graph signals, which captures both the structure information (or connectivity between nodes) and data (or attributes at nodes). A graph signal consists of a graph $\mathcal{G} = \{\mathcal{V}, \mathcal{E}\}$, and a mapping function f defined in the graph domain, which maps the nodes to real values. Mathematically, the mapping function can be represented as:

$$f : \mathcal{V} \rightarrow \mathbb{R}^{N \times d},$$

where d is the dimension of the value (vector) associated with each node. Without loss of generality, in this section, we set $d = 1$ and denote the mapped values for all nodes as $\mathbf{f} \in \mathbb{R}^N$ with $\mathbf{f}[i]$ corresponding to node v_i .

Example 2.32 A graph signal is shown in Figure 2.3, where the color of a node represents its associated value with smaller values tending toward blue and larger values tending toward red.

A graph is smooth if the values in connected nodes are similar. A smooth graph signal is with low frequency, as the values change slowly across the graph via the edges. The Laplacian matrix quadratic form in Eq. (2.10) can be utilized to measure the smoothness (or the frequency) of a graph signal \mathbf{f} as it is the summation of the square of the difference between all pairs of connected nodes. Specifically, when a graph signal \mathbf{f} is smooth, $\mathbf{f}^T \mathbf{L} \mathbf{f}$ is small. The value $\mathbf{f}^T \mathbf{L} \mathbf{f}$ is called as the smoothness (or the frequency) of the signal \mathbf{f} .

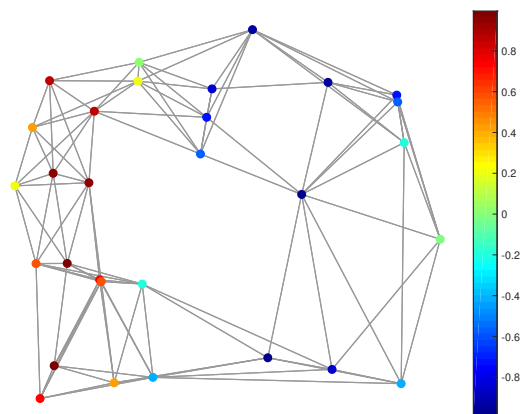

Figure 2.3 A one-dimensional graph signal

In the classical signal processing setting, a signal can be denoted in two domains, i.e., the time domain and the frequency domain. Similarly, the graph signal can also be represented in two domains, i.e., the spatial domain, which we just introduced, and the spectral domain (or frequency domain). The spectral domain of graph signals is based on the Graph Fourier Transform. It is built upon the spectral graph theory that we have introduced in the previous section.

2.5.1 Graph Fourier Transform

The classical Fourier Transform (Bracewell, n.d.)

$$\hat{f}(\xi) = \langle f(t), \exp(-2\pi i t \xi) \rangle = \int_{-\infty}^{\infty} f(t) \exp(-2\pi i t \xi) dt$$

decomposes a signal $f(t)$ into a series of complex exponentials $\exp(-2\pi i t \xi)$ for any real number ξ , where ξ can be viewed as the frequency of the corresponding exponential. These exponentials are the eigenfunctions of the one-dimensional Laplace operator (or the second order differential operator) as we

have

$$\begin{aligned}\nabla(\exp(-2\pi i t \xi)) &= \frac{\partial^2}{\partial t^2} \exp(-2\pi i t \xi) \\ &= \frac{\partial}{\partial t} (-2\pi i \xi) \exp(-2\pi i t \xi) \\ &= -(2\pi i \xi)^2 \exp(-2\pi i t \xi).\end{aligned}$$

Analogously, the Graph Fourier Transform for a graph signal \mathbf{f} on graph \mathcal{G} can be represented as:

$$\hat{\mathbf{f}}[l] = \langle \mathbf{f}, \mathbf{u}_l \rangle = \sum_{i=1}^N \mathbf{f}[i] \mathbf{u}_l[i], \quad (2.11)$$

where \mathbf{u}_l is the l -th eigenvector of the Laplacian matrix \mathbf{L} of the graph. The corresponding eigenvalue λ_l represents the frequency or the smoothness of the eigenvector \mathbf{u}_l . The vector $\hat{\mathbf{f}}$ with $\hat{\mathbf{f}}[l]$ as its l -th element is the Graph Fourier Transform of \mathbf{f} . The eigenvectors are the graph Fourier basis of the graph \mathcal{G} , and $\hat{\mathbf{f}}$ consists of the graph Fourier coefficients corresponding to these basis for a signal \mathbf{f} . The Graph Fourier Transform of \mathbf{f} can be also denoted in the matrix form as:

$$\hat{\mathbf{f}} = \mathbf{U}^T \mathbf{f} \quad (2.12)$$

where the l -th column of the matrix \mathbf{U} is \mathbf{u}_l .

As suggested by the following equation:

$$\mathbf{u}_l^T \mathbf{L} \mathbf{u}_l = \lambda_l \cdot \mathbf{u}_l^T \mathbf{u}_l = \lambda_l,$$

the eigenvalue λ_l measures the smoothness of the corresponding eigenvector \mathbf{u}_l . Specifically, the eigenvectors associated with small eigenvalues vary slowly across the graph. In other words, the values of such eigenvector at connected nodes are similar. Thus, these eigenvectors are smooth and change with low frequency across the graph. However, the eigenvectors corresponding to large eigenvalues may have very different values on two nodes, even if connected. An extreme example is the first eigenvector \mathbf{u}_1 associated with the eigenvalue 0 – it is constant over all the nodes, which indicates that its value does not change across the graph. Hence, it is extremely smooth and has an extremely low frequency 0. These eigenvectors are the graph Fourier basis for the graph \mathcal{G} , and their corresponding eigenvalues indicate their frequencies. The Graph Fourier Transform, as shown in Eq. (2.12) can be regarded as a process to decompose an input signal \mathbf{f} into graph Fourier basis with different frequencies. The obtained coefficients $\hat{\mathbf{f}}$ denote how much the corresponding graph Fourier basis contributes to the input signal.

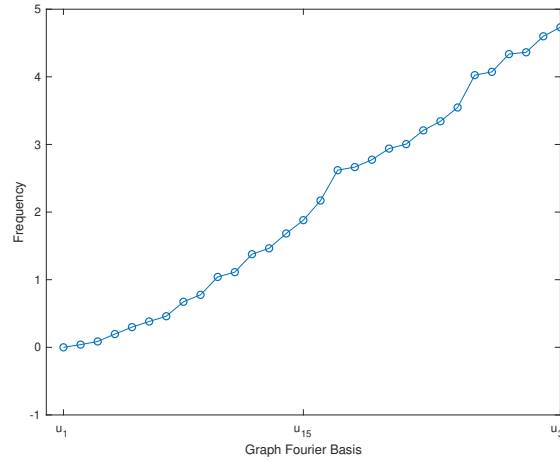

Figure 2.4 Frequencies of graph Fourier basis

Example 2.33 Figure 2.4 shows the frequencies of the graph Fourier basis of the graph shown in Figure 2.3. Note that the frequency of \mathbf{u}_1 is 0.

The graph Fourier coefficients $\hat{\mathbf{f}}$ are the representation of the signal \mathbf{f} in the spectral domain. There is also the Inverse Graph Fourier Transform, which can transform the spectral representation $\hat{\mathbf{f}}$ to the spatial representation \mathbf{f} as:

$$\mathbf{f}[i] = \sum_{l=1}^N \hat{f}[l] \mathbf{u}_l[i].$$

This process can also be represented in the matrix form as follows:

$$\mathbf{f} = \mathbf{U}\hat{\mathbf{f}}.$$

In summary, a graph signal can be denoted in two domains, i.e., the spatial domain and the spectral domain. The representations in the two domains can be transformed to each other via the Graph Fourier Transform and the Inverse Graph Fourier Transform, respectively.

Example 2.34 Figure 2.5 shows a graph signal in both the spatial and spectral domains. Specifically, Figure 2.5a shows the graph signal in the spatial domain and Figure 2.5b illustrates the same graph signal in the spectral domain. In Figure 2.5b, the x-axis is the graph Fourier basis and the y-axis indicates the corresponding graph Fourier coefficients.

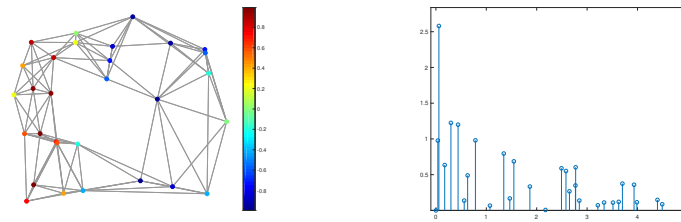

(a) A graph signal in the spatial domain (b) A graph signal in the spectral domain

Figure 2.5 Representations of a graph signal in both spatial and spectral Domains

2.6 Complex Graphs

In the earlier sections, we introduced simple graphs and their fundamental properties. However, graphs in real-world applications are much more complicated. In this section, we briefly describe popular complex graphs with formal definitions.

2.6.1 Heterogeneous Graphs

The simple graphs we have discussed are homogeneous. They only have one type of nodes as well as a single type of edges. However, in many real-world applications, we want to model multiple types of relations between multiple types of nodes. As shown in Figure 2.6, in an academic network describing publications and citations, there are three types of nodes, including authors, papers, and venues. There are also various kinds of edges denoting different relations between the nodes. For example, there exist edges describing the citation relations between papers or edges denoting the authorship relations between authors and papers. Next, we formally define heterogeneous graphs.

Definition 2.35 (Heterogeneous Graphs) A heterogeneous graph \mathcal{G} consists of a set of nodes $\mathcal{V} = \{v_1, \dots, v_N\}$ and a set of edges $\mathcal{E} = \{e_1, \dots, e_M\}$ where each node and each edge are associated with a type. Let \mathcal{T}_n denote the set of node types and \mathcal{T}_e indicate the set of edge types. There are two mapping functions $\phi_n : \mathcal{V} \rightarrow \mathcal{T}_n$ and $\phi_e : \mathcal{E} \rightarrow \mathcal{T}_e$ that map each node and each edge to their types, respectively.

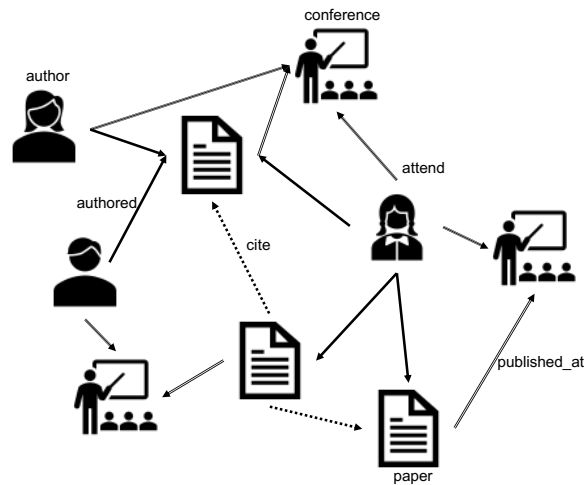

Figure 2.6 A heterogeneous academic graph

2.6.2 Bipartite Graphs

In a bipartite graph $\mathcal{G} = \{\mathcal{V}, \mathcal{E}\}$, its node set \mathcal{V} can be divided into two disjoint subsets \mathcal{V}_1 and \mathcal{V}_2 where every edge in \mathcal{E} connects a node in \mathcal{V}_1 to a node in \mathcal{V}_2 . Bipartite graphs are widely used to capture interactions between different objects. For example, as shown in Figure 2.7, in many e-commerce platforms such as Amazon, the click history of users can be modeled as a bipartite graph where the users and items are the two disjoint node sets, and users' click behaviors form the edges between them. Next, we formally define bipartite graphs.

Definition 2.36 (Bipartite Graph) Given a graph $\mathcal{G} = \{\mathcal{V}, \mathcal{E}\}$, it is bipartite if and only if $\mathcal{V} = \mathcal{V}_1 \cup \mathcal{V}_2$, $\mathcal{V}_1 \cap \mathcal{V}_2 = \emptyset$ and $v_e^1 \in \mathcal{V}_1$ while $v_e^2 \in \mathcal{V}_2$ for all $e = (v_e^1, v_e^2) \in \mathcal{E}$.

2.6.3 Multi-dimensional Graphs

In many real-world graphs, multiple relations can simultaneously exist between a pair of nodes. One example of such graph can be found at the popular video-sharing site YouTube, where users are viewed as nodes. YouTube users can subscribe to each other, which is considered as one relation. Users can be connected via other relations such as “sharing” or “commenting” videos from other users. Another example is from e-commerce sites such as Amazon,

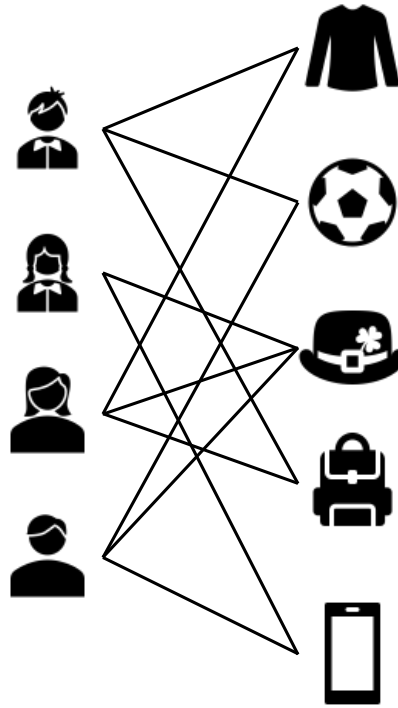

Figure 2.7 An e-commerce bipartite graph

where users can interact with items through various types of behaviors such as “click”, “purchase” and “comment”. These graphs with multiple relations can be naturally modeled as multi-dimensional graphs by considering each type of relations as one dimension.

Definition 2.37 (Multi-dimensional graph) A multi-dimensional graph consists of a set of N nodes $\mathcal{V} = \{v_1, \dots, v_N\}$ and D sets of edges $\{\mathcal{E}_1, \dots, \mathcal{E}_D\}$. Each edge set \mathcal{E}_d describes the d -th type of relations between the nodes in the corresponding d -th dimension. These D types of relations can also be expressed by D adjacency matrices $\mathbf{A}^{(1)}, \dots, \mathbf{A}^{(D)}$. In the dimension d , its corresponding adjacency matrix $\mathbf{A}^{(d)} \in \mathbb{R}^{N \times N}$ describes the edges \mathcal{E}_d between nodes in \mathcal{V} . Specifically, the i, j -th element of $\mathbf{A}^{(d)}$, denoted as $\mathbf{A}_{i,j}^{(d)}$, equals to 1 only when there is an edge between nodes v_i and v_j in the dimension d (or $(v_i, v_j) \in \mathcal{E}_d$), otherwise 0.

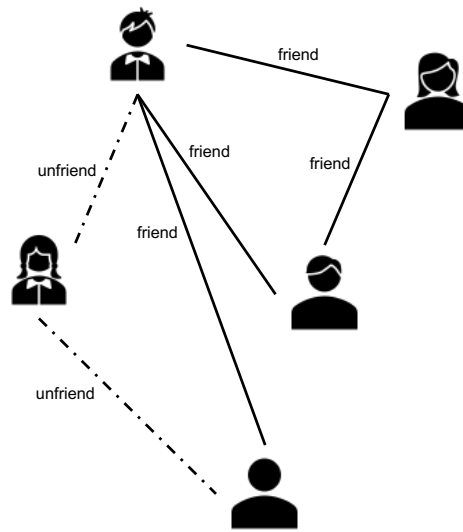

Figure 2.8 An illustrative signed graph

2.6.4 Signed Graphs

Signed graphs, which contain both positive and negative edges, have become increasingly ubiquitous with the growing popularity of the online social networks. Examples of signed graphs are from online social networks such as Facebook and Twitter, where users can block or unfollow other users. The behaviour of “block” can be viewed as negative edges between users. Meanwhile, the behaviour of “unfriend” can also be treated as negative edges. An illustrative example of a signed graph is shown in Figure 2.8, where users are nodes and “unfriend” and “friend” relations are the “negative” and “positive” edges, respectively. Next, we give the formal definition of signed graphs.

Definition 2.38 (Signed Graphs) Let $\mathcal{G} = \{\mathcal{V}, \mathcal{E}^+, \mathcal{E}^-\}$ be a signed graph, where $\mathcal{V} = \{v_1, \dots, v_N\}$ is the set of N nodes while $\mathcal{E}^+ \subset \mathcal{V} \times \mathcal{V}$ and $\mathcal{E}^- \subset \mathcal{V} \times \mathcal{V}$ denote the sets of positive and negative edges, respectively. Note that an edge can only be either positive or negative, i.e., $\mathcal{E}^+ \cap \mathcal{E}^- = \emptyset$. These positive and negative edges between nodes can also be described by a signed adjacency matrix \mathbf{A} , where $\mathbf{A}_{i,j} = 1$ only when there is a positive edge between node v_i and node v_j , $\mathbf{A}_{i,j} = -1$ denotes a negative edge, otherwise $\mathbf{A}_{i,j} = 0$.

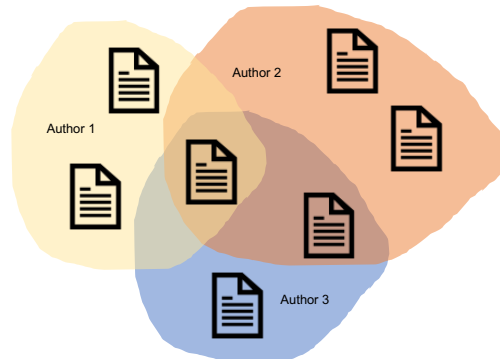

Figure 2.9 An illustrative hypergraph

2.6.5 Hypergraphs

The graphs we introduced so far only encode pairwise information via edges. However, in many real-world applications, relations are beyond pairwise associations. Figure 2.9 demonstrates a hypergraph describing the relations between papers. An specific author can publish more than two papers. Thus, the author can be viewed as a hyperedge connecting multiple papers (or nodes). Compared with edges in simple graphs, hyperedges can encode higher-order relations. The graphs with hyperedges are called as hypergraphs. Next, we give the formal definition of hypergraphs.

Definition 2.39 (Hypergraphs) Let $\mathcal{G} = \{\mathcal{V}, \mathcal{E}, \mathbf{W}\}$ be a hypergraph, where \mathcal{V} is a set of N nodes, \mathcal{E} is a set of hyperedges and $\mathbf{W} \in \mathbb{R}^{|\mathcal{E}| \times |\mathcal{E}|}$ is a diagonal matrix with $\mathbf{W}_{j,j}$ denoting the weight of the hyperedge e_j . The hypergraph \mathcal{G} can be described by an incidence matrix $\mathbf{H} \in \mathbb{R}^{|\mathcal{V}| \times |\mathcal{E}|}$, where $\mathbf{H}_{i,j} = 1$ only when the node v_i is incident to the edge e_j . For a node v_i , its degree is defined as $d(v_i) = \sum_{j=1}^{|\mathcal{E}|} \mathbf{H}_{i,j}$, while the degree for a hyperedge is defined as $d(e_j) = \sum_{i=1}^{|\mathcal{V}|} \mathbf{H}_{i,j}$. Furthermore, we use \mathbf{D}_e and \mathbf{D}_v to denote the diagonal matrices of the edge and node degrees, respectively.

2.6.6 Dynamic Graphs

The graphs mentioned above are static, where the connections between nodes are fixed when observed. However, in many real-world applications, graphs are constantly evolving as new nodes are added to the graph, and new edges are

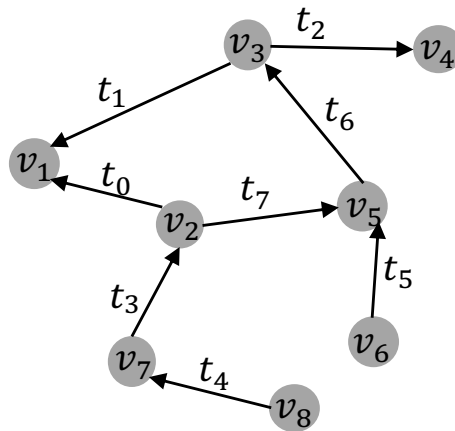

Figure 2.10 An illustrative example of dynamic graphs.

continuously emerging. For example, in online social networks such as Facebook, users can constantly establish friendships with others, and new users can also join Facebook at any time. These kinds of evolving graphs can be denoted as dynamic graphs where each node or edge is associated with a timestamp. An illustrative example of dynamic graphs is shown in Figure 2.10, where each edge is associated with a timestamp, and the timestamp of a node is when the very first edge involves the node. Next, we give a formal definition of dynamic graphs.

Definition 2.40 (Dynamic Graphs) A dynamic graph $\mathcal{G} = \{\mathcal{V}, \mathcal{E}\}$, consists of a set of nodes $\mathcal{V} = \{v_1, \dots, v_N\}$ and a set of edges $\mathcal{E} = \{e_1, \dots, e_M\}$ where each node and/or each edge is associated with a timestamp indicating the time it emerged. Specifically, we have two mapping functions ϕ_v and ϕ_e mapping each node and each edge to their emerging timestamps.

In reality, we may not be able to record the timestamp of each node and/or each edge. Instead, we only check from time to time to observe how the graph evolves. At each observation timestamp t , we can record the snapshot of the graph \mathcal{G}_t as the observation. We refer to this kind of dynamic graphs as discrete dynamic graphs, which consist of multiple graph snapshots. We formally define the discrete dynamic graph as follows.

Definition 2.41 (Discrete Dynamic Graphs) A discrete dynamic graph consists of T graph snapshots, which are observed along with the evolution of a dy-

dynamic graph. Specifically, the T graph snapshots can be denoted as $\{\mathcal{G}_0, \dots, \mathcal{G}_T\}$ where \mathcal{G}_0 is the graph observed at time 0.

2.7 Computational Tasks on Graphs

There are a variety of computational tasks proposed for graphs. These tasks can be mainly divided into two categories. One is node-focused tasks, where the entire data is usually represented as one graph with nodes as the data samples. The other is graph-focused tasks, where data often consists of a set of graphs, and each data sample is a graph. In this section, we briefly introduce representative tasks for each group.

2.7.1 Node-focused Tasks

Numerous node-focused tasks have been extensively studied, such as node classification, node ranking, link prediction, and community detection. Next, we discuss two typical tasks, including node classification and link prediction.

Node classification

In many real-world graphs, nodes are associated with useful information, often treated as labels of these nodes. For example, in social networks, such information can be demographic properties of users such as age, gender, and occupation, or users' interests and hobbies. These labels usually help characterize the nodes and can be leveraged for many important applications. For example, in social media such as Facebook, labels related to interests and hobbies can be utilized to recommend relevant items (i.e., news and events) to their users. However, in reality, it is often difficult to get a full set of labels for all nodes. For example, less than 1% of Facebook users provide their complete demographic properties. Hence, we are likely given a graph with only a part of the nodes associated with labels, and we aim to infer the labels for nodes without labels. It motivates the problem of node classification on graphs.

Definition 2.42 (Node classification) Let $\mathcal{G} = \{\mathcal{V}, \mathcal{E}\}$ denote a graph with \mathcal{V} the set of nodes and \mathcal{E} the set of edges. Some of the nodes in \mathcal{V} are associated with labels, and the set of these labeled nodes is represented as $\mathcal{V}_l \subset \mathcal{V}$. The remaining nodes do not have labels, and this set of unlabeled nodes is denoted as \mathcal{V}_u . Specifically, we have $\mathcal{V}_l \cup \mathcal{V}_u = \mathcal{V}$ and $\mathcal{V}_l \cap \mathcal{V}_u = \emptyset$. The goal of the node classification task is to learn a mapping ϕ by leveraging \mathcal{G} and labels of \mathcal{V}_l , which can predict the labels of unlabeled nodes (or $v \in \mathcal{V}_u$).

The above definition is for simple graphs that can be easily extended to graphs with attributes and complex graphs we introduced in Section 2.6.

Example 2.43 (Node Classification in Flickr) Flickr is an image hosting platform that allows users to host their photos. It also serves as an online social community where users can follow each other. Hence, users in Flickr and their connections form a graph. Furthermore, users in Flickr can subscribe to interest groups such as “*Black and White*”, “*The Fog and The Rain*”, and “*Dog World*”. These subscriptions indicate the interests of users and can be used as their labels. A user can subscribe to multiple groups. Hence, each user can be associated with multiple labels. A multi-label node classification problem on graphs can help predict the potential groups that users are interested in, but they have not yet subscribed to. One such dataset on Flickr can be found in (Tang and Liu, 2009).

Link Prediction

In many real-world applications, graphs are not complete but with missing edges. Some of the connections exist. However, they are not observed or recorded, which leads to missing edges in the observed graphs. Meanwhile, many graphs are naturally evolving. In social media such as Facebook, users can continuously become friends with other users. In academic collaboration graphs, a given author can constantly build new collaboration relations with other authors. Inferring or predicting these missing edges can benefit many applications such as friend recommendation (Adamic and Adar, 2003), knowledge graph completion (Nickel et al., 2015), and criminal intelligence analysis (Berlusconi et al., 2016). Next, we give the formal definition of the link prediction problem.

Definition 2.44 (Link Prediction) Let $\mathcal{G} = \{\mathcal{V}, \mathcal{E}\}$ denote a graph with \mathcal{V} as its set of nodes and \mathcal{E} as its set of edges. Let \mathcal{M} denote all possible edges between nodes in \mathcal{V} . Then, we denote the complementary set of \mathcal{E} with respect to \mathcal{M} as $\mathcal{E}' = \mathcal{M}/\mathcal{E}$. The set \mathcal{E}' contains the unobserved edges between the nodes. The goal of the link prediction task is to predict the edges that most likely exist. Specifically, a score can be assigned to each of the edges in \mathcal{E}' . It indicates how likely the edge exists or will emerge in the future.

Note that the definition is stated for simple graphs and can be easily extended to complex graphs we introduced in Section 2.6. For example, for signed graphs, in addition to the existence of an edge, we also want to predict its sign. For hypergraphs, we want to infer hyperedges which describe the relations between multiple nodes.

Example 2.45 (Predicting Emerging Collaborations in DBLP) DBLP is an online computer science bibliography website that hosts a comprehensive list of research papers in computer science. A co-authorship graph can be constructed from the papers in DBLP, where the authors are the nodes, and authors can be considered as connected if they have co-authored at least one paper as recorded in DBLP. Predicting what new collaborations between authors who never co-authored before is an interesting link prediction problem. A large DBLP collaboration dataset for link prediction research can be found in (Yang and Leskovec, 2015).

2.7.2 Graph-focused Tasks

There are numerous graph-focused tasks, such as graph classification, graph matching, and graph generation. Next, we discuss the most representative graph-focused task, i.e., graph classification.

Graph Classification

Node classification treats each node in a graph as a data sample and aims to assign labels to these unlabeled nodes. In some applications, each sample can be represented as a graph. For example, in chemoinformatics, chemical molecules can be denoted as graphs where atoms are the nodes, and chemical bonds between them are the edges. These chemical molecules may have different properties such as solubility and toxicity, which can be treated as their labels. In reality, we may want to predict these properties for newly discovered chemical molecules automatically. This goal can be achieved by the task of graph classification, which aims to predict the labels for unlabeled graphs. Graph classification cannot be carried out by traditional classification due to the complexity of graph structures. Thus, dedicated efforts are desired. Next, we provide a formal definition of graph classification.

Definition 2.46 (Graph Classification) Given a set of labeled graphs $\mathcal{D} = \{(\mathcal{G}_i, y_i)\}$ with y_i as the label of the graph \mathcal{G}_i , the goal of the graph classification task is to learn a mapping function ϕ with \mathcal{D} , which can predict the labels of unlabeled graphs.

In the definition above, we did not specify additional information potentially associated with the graphs. For example, in some scenarios, each node in a graph is associated with certain features that can be utilized for graph classification.

Example 2.47 (Classifying Proteins into Enzymes or Non-enzymes) Proteins

can be represented as graphs, where amino acids are the nodes, and edges between two nodes are formed if they are less than 6\AA apart. Enzymes are a type of proteins which serve as biological catalysts to catalyze biochemical reactions. Given a protein, predicting whether it is an enzyme or not can be treated as a graph classification task where the label for each protein is either enzyme or non-enzyme.

2.8 Conclusion

In this chapter, we briefly introduced the concepts of graphs, the matrix representations of graphs, and the important measures and properties of graphs, including degree, connectivity, and centrality. We then discuss Graph Fourier Transform and graph signal processing, which lay the foundations for spectral based graph neural networks. We introduce a variety of complex graphs. Finally, we discuss representative computational tasks on graphs, including both node-focused and graph-focused tasks.

2.9 Further Reading

We briefly introduce many basic concepts in graphs. There are also other more advanced properties and concepts in graphs such as flow and cut. Furthermore, there are many problems defined on graphs, including graph coloring problem, route problem, network flow problem, and covering problem. These concepts and topics are covered by the books (Bondy *et al.*, n.d.; Newman, 2018). Meanwhile, more spectral properties and theories on graphs can be found in the book (Chung and Graham, 1997). Applications of graphs in different areas can be found in (Borgatti *et al.*, 2009; Nastase *et al.*, 2015; Trinajstić, 2018). The Stanford Large Network Dataset Collection (Leskovec and Krevl, 2014) and the Network Data Repository (Rossi and Ahmed, 2015), host large amounts of graph datasets from various areas. The python libraries *networkx* (Hagberg *et al.*, 2008), *graph-tool* (Peixoto, 2014), and SNAP (Leskovec and Sosič, 2016) can be used to analyze and visualize graph data. The *Graph Signal Processing Toolbox* (Perraudin *et al.*, 2014) can be employed to perform graph signal processing.

3

Foundations of Deep Learning

3.1 Introduction

Machine learning is the research field of allowing computers to learn to act appropriately from sample data without being explicitly programmed. Deep learning is a class of machine learning algorithms that is built upon artificial neural networks. In fact, most of the vital building components of deep learning have existed for decades, while deep learning only gains its popularity in recent years. The idea of artificial neural networks dates back to 1940s when McCulloch-Pitts Neuron (McCulloch and Pitts, 1943) was first introduced. This linear model can recognize inputs from two categories by linearly aggregating information from inputs and then making the decision. Later on, the perceptron (Rosenblatt, 1958) was developed, which can learn its parameters given training samples. The research of neural networks revived in the 1980s. One of the breakthroughs during this period is the successful use of the back-propagation algorithm (Rumelhart et al., 1986; Le Cun and Fogelman-Soulié, 1987) to train deep neural network models. Note that the back-propagation algorithm has many predecessors dating to the 1960s and was first mentioned by Werbos to train neural networks (Werbos, 1994). The back-propagation algorithm is still the dominant algorithm to train deep models in the modern ages of deep learning. Deep learning research revived and gained unprecedented attention with the availability of “big data” and powerful computational resources in recent years. The emerging of fast GPUs allows us to train deep models with immense size while the increasingly large data ensures that these models can generalize well. These two advantages lead to the tremendous success of deep learning techniques in various research areas and result in immense real-world impact. Deep neural networks have outperformed state-of-the-art traditional methods by a large margin in multiple applications. Deep learning has significantly advanced the performance of the

image recognition task. The ImageNet Large-Scale Visual Recognition Challenge (ILSVRC) is the largest contest in image recognition, which is held each year between 2010 and 2017. In 2012, the deep convolutional neural network (CNN) won this challenge for the first time by a large margin, reducing top-5 error rate from 26.1% to 15.3% (Krizhevsky et al., 2012). Since then, the deep convolutional neural networks (CNNs) have consistently won the competition, which further pushed the error rate down to 3.57% (He et al., 2016). Deep learning has also dramatically improved the performance of speech recognition systems (Dahl et al., 2010; Deng et al., 2010; Seide et al., 2011). The introduction of deep learning techniques to speech recognition leads to a massive drop in error rates, which have stagnated for years. The deep learning techniques have massively accelerated the research field of Natural Language Processing (NLP). Recurrent Neural Networks such as LSTM (Hochreiter and Schmidhuber, 1997) have been broadly used in sequence-to-sequence tasks such as machine translation (Sutskever et al., 2014; Bahdanau et al., 2014) and dialogue systems (Vinyals and Le, 2015). As the research of “deep learning on graphs” has its root in deep learning, understanding some basic deep learning techniques is essential. Hence, in this chapter, we briefly introduce fundamental deep learning techniques, including feedforward neural networks, convolutional neural networks, recurrent neural networks, and autoencoders. They will serve as the foundations for deep learning on graphs. Though we focus on basic deep models in this chapter, we will extend our discussion to advanced deep models such as variational autoencoders and generative adversarial networks in the later chapters.

3.2 Feedforward Networks

Feedforward networks are the basis for many important deep learning techniques. A feedforward network is to approximate a certain function $f^*(\mathbf{x})$ using given data. For example, for the classification task, an ideal classifier $f^*(\mathbf{x})$ maps an input \mathbf{x} to a target category y . In this case, a feedforward network is supposed to find a mapping $f(\mathbf{x}|\Theta)$ such that it can approximate the ideal classifier $f^*(\mathbf{x})$ well. Specifically, the goal of training the feedforward network is to learn the values of the parameters Θ that can result in the best approximation to $f^*(\mathbf{x})$.

In feedforward networks, the information \mathbf{x} flows from the input, through some intermediate computations, and finally to the output y . The intermediate computational operations are in the form of networks, which can typically be represented as the composition of several functions. For example, the feedfor-

ward network shown in Figure 3.1 has four functions $f^{(1)}, f^{(2)}, f^{(3)}, f^{(4)}$ connected in a chain and $f(\mathbf{x}) = f^{(4)}(f^{(3)}(f^{(2)}(f^{(1)}(\mathbf{x})))$. In the feedforward network shown in Figure 3.1, $f^{(1)}$ is the first layer, $f^{(2)}$ is the second layer, $f^{(3)}$ is the third layer and the final layer $f^{(4)}$ is the output layer. The number of computational layers in the network defines the depth of the network. During the training of the neural network, we try to push the output $f(\mathbf{x})$ to be close to the ideal output, i.e., $f^*(\mathbf{x})$ or y . During the training process, the results from the output layer are directly guided by the training data. In contrast, all the intermediate layers do not obtain direct supervision from the training data. Thus, to approximate the ideal function $f^*(\mathbf{x})$ well, the learning algorithm decides the intermediate layers' parameters using the indirect supervision signal passing back from the output layer. Since no desired output is given for the intermediate layers from the training data during the training procedure, these intermediate layers are called hidden layers. As discussed before, each layer of

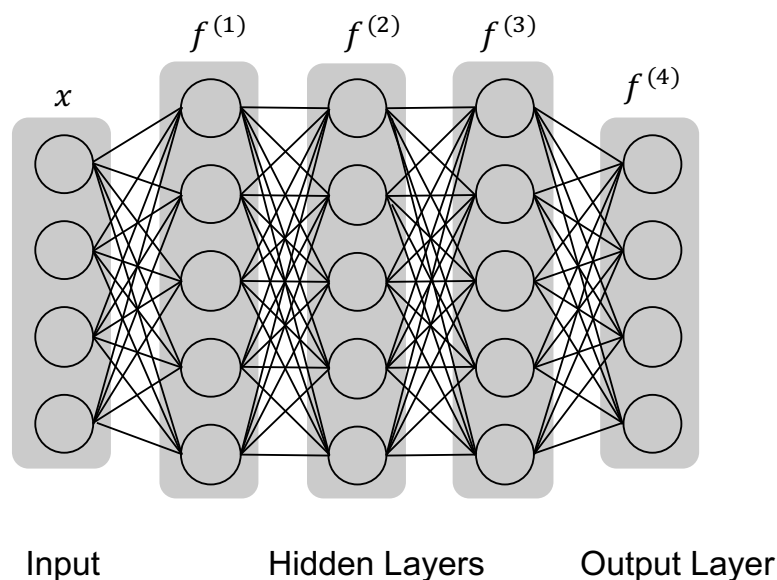

Figure 3.1 An illustrative example of feedforward networks

the neural network can be viewed as a vector-valued function, where both the input and output are vectors. The elements in the layer can be treated as nodes (or units). Thus, each layer can be considered as a set of vector-to-scalar functions where each node is a function. The networks are called neural networks as Neuroscience loosely inspires them. The operation in a node loosely mimics

what happens on a neuron in the brain, activated when it encounters sufficient stimuli. A node gathers and transforms information from all the nodes in the previous layer and then passes it through an activation function, which determines to what extent the information can pass through to the next layer. The operation of gathering and transforming information is typically linear, while the activation function adds non-linearity to the neural network, which largely improves its approximation capability.

3.2.1 The Architecture

In a fully connected feedforward neural network, nodes in consecutive layers form a complete bipartite graph, i.e., a node in one layer is connected to all nodes in the other layer. A general view of this architecture is demonstrated in Figure 3.1. Next we introduce the details of the computation involved in the neural network. To start, we focus on a single node in the first layer. The input of the neural network is a vector \mathbf{x} where we use x_i to denote its i -th element. All these elements can be viewed as nodes in the input layer. A node in the second layer (or the one after the input layer) is connected to all nodes in the input layer. These connections between the nodes in the input layer and an arbitrary node in the second layer are illustrated in Figure 3.2. The operations in one node consist of two parts: 1) combining the elements of

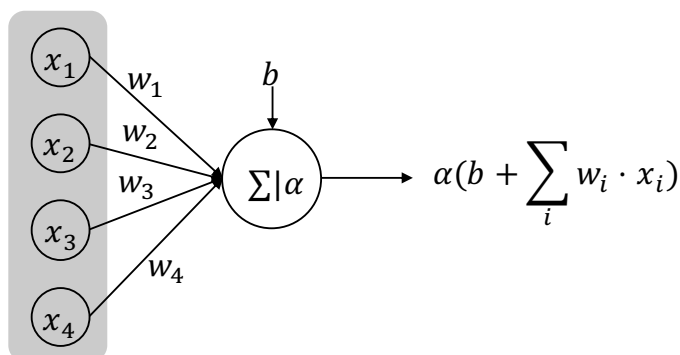

Figure 3.2 Operations in one node

the input linearly with various weights (or w_i); 2) passing the value obtained in the previous step through an activation function. Mathematically, it can be

represented as

$$h = \alpha(b + \sum_{i=1}^4 \mathbf{w}_i \cdot \mathbf{x}_i),$$

where b is a bias term and $\alpha(\cdot)$ is an activation function, which will be introduced in next section. We now generalize the operation to an arbitrary hidden layer. Assume that in the k -th layer of the neural network, we have $N^{(k)}$ nodes and the output of the layer can be represented as $\mathbf{h}^{(k)}$ with $\mathbf{h}_i^{(k)}$ denoting its i -th element. Then, to compute $\mathbf{h}_j^{(k+1)}$ in the $(k+1)$ -th layer, the following operation is conducted:

$$\mathbf{h}_j^{(k+1)} = \alpha(b_j^{(k)} + \sum_{i=1}^{N^{(k)}} \mathbf{W}_{ji}^{(k)} \mathbf{h}_i^{(k)}). \quad (3.1)$$

Note that we use $\mathbf{W}_{ji}^{(k)}$ to denote the weight corresponding to the connection between $\mathbf{h}_i^{(k)}$ and $\mathbf{h}_j^{(k+1)}$ and $b_j^{(k)}$ is the bias term for calculating $\mathbf{h}_j^{(k+1)}$. The operations to calculate all the elements in the $(k+1)$ -th layer can be summarized in the matrix form as:

$$\mathbf{h}^{(k+1)} = \alpha(\mathbf{b}^{(k)} + \mathbf{W}^{(k)} \mathbf{h}^{(k)}),$$

where $\mathbf{W}^{(k)} \in \mathbb{R}^{N^{(k+1)} \times N^{(k)}}$ contains all weights and its j, i -th element is $\mathbf{W}_{ji}^{(k)}$ in Eq. (3.1) and $\mathbf{b}^{(k)}$ consists of all bias terms. Specifically, for the input layer, we have $\mathbf{h}^{(0)} = \mathbf{x}$. Recall that we use $f^{(k+1)}$ to represent the operation of the $(k+1)$ -th layer in the neural network; thus we have

$$\mathbf{h}^{(k+1)} = f^{(k+1)}(\mathbf{h}^{(k)}) = \alpha(\mathbf{b}^{(k)} + \mathbf{W}^{(k)} \mathbf{h}^{(k)}).$$

Note that the introduced operations are typical for hidden layers. The output layer usually adopts a similar structure, but different activation functions to transform the obtained information. We next introduce activation functions and the design of the output layer.

3.2.2 Activation Functions

An activation function decides whether or to what extent the input signal should pass. The node (or neuron) is activated if there is information passing through it. As introduced in the previous section, the operations of a neural network are linear without activation functions. The activation function introduces the non-linearity into the neural network that can improve its approximation capability. In the following, we introduce some commonly used activation functions.

Rectifier

Rectifier is one of the most commonly used activation functions. As shown in Figure 3.3, it is similar to linear functions, and the only difference is that the rectifier outputs 0 on the negative half of its domain. In the neural network, the units employed this activation function are called as Rectifier Linear Units (ReLU). The rectifier activation function is linear (identity) for all positive input values and 0 for all negative values. Mathematically, it is defined as:

$$\text{ReLU}(z) = \max\{0, z\}.$$

At each layer, only a few of the units are activated, which ensures efficient computation. One drawback of the rectified linear unit is that its gradient is 0 on the negative half of the domain. Hence if the unit is not activated, no supervision information can be passed back for training that unit. Some generalizations of ReLU have been proposed to overcome this drawback. Instead of setting the negative input to 0, LeakyReLU (Maas et al., 2013) performs a linear transformation with a small slope to the negative values as shown in Figure 3.4a. More specifically, LeakyReLU can be mathematically represented as:

$$\text{LeakyReLU}(z) = \begin{cases} 0.01z & z < 0 \\ z & z \geq 0, \end{cases}$$

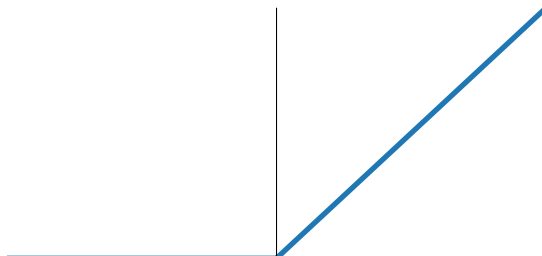

Figure 3.3 ReLU

Another generalization of ReLU is the exponential linear unit (ELU). It still has the identity transform for the positive values but it adopts an exponential transform for the negative values as shown in Figure 3.4b. Mathematically, the ELU activation function can be represented as:

$$\text{ELU}(z) = \begin{cases} c \cdot \exp(z - 1) & z < 0 \\ z & z \geq 0, \end{cases}$$

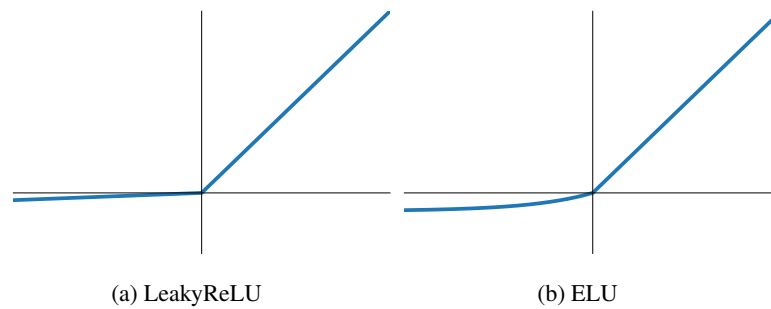

Figure 3.4 Generalizations of ReLU

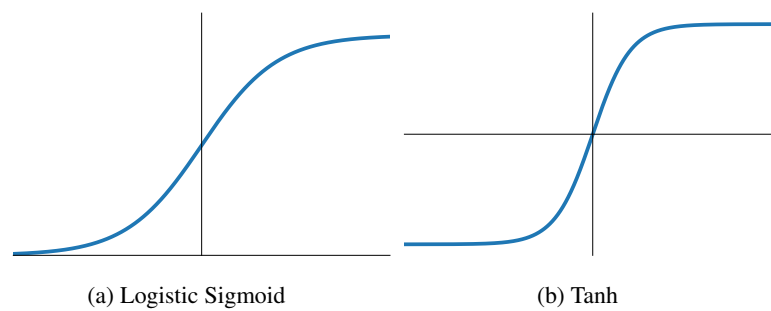

Figure 3.5 Logistic sigmoid and hyperbolic tangent

where c is a positive constant controlling the slope of the exponential function for the negative values.

Logistic Sigmoid and Hyperbolic Tangent

Prior to the ReLU, logistic sigmoid and the hyperbolic tangent functions are the most commonly adopted activation functions. The sigmoid activation function can be mathematically represented as follows:

$$\sigma(z) = \frac{1}{1 + \exp(-z)}$$

As shown in Figure 3.5a, the sigmoid function maps the input into the range of 0 to 1. Specifically, the more negative the input is, the closer the output is to 0 and the more positive the input is, the closer the output is to 1.

The hyperbolic tangent activation function is highly related to the sigmoid function with the following relation:

$$\tanh(z) = \frac{2}{1 + \exp(-2z)} - 1 = 2 \cdot \sigma(2z) - 1.$$

As shown in Figure 3.5b, the hyperbolic tangent function maps the input into the range of -1 to 1 . Specifically, the more negative the input is, the closer the output is to -1 and the more positive the input is, the closer the output is to 1 .

These two activation functions face the same saturation issue (Nwankpa et al., 2018). They saturate when the input z is a huge positive number or a very negative number. They are only sensitive to values that are close to 0. The phenomenon of the widespread saturation makes gradient-based training very difficult, as the gradient will be around 0 when z is either very positive or very negative. For this reason, these two activation functions are becoming less popular in feedforward networks.

3.2.3 Output Layer and Loss Function

The choice of the output layer and loss function varies according to the applications. Next, we introduce some commonly used output units and loss functions.

In regression tasks, a neural network needs to output continuous values. A simple way to achieve this is to perform an affine transformation (or an affinity) without the non-linear activation. Given input features (or features from previous layers) $\mathbf{h} \in \mathbb{R}^{d_{in}}$, a layer of linear units outputs a vector $\hat{\mathbf{y}} \in \mathbb{R}^{d_{ou}}$ as:

$$\hat{\mathbf{y}} = \mathbf{W}\mathbf{h} + \mathbf{b},$$

where $\mathbf{W} \in \mathbb{R}^{d_{ou} \times d_{in}}$ and $\mathbf{b} \in \mathbb{R}^{d_{ou}}$ are the parameters to be learned. For a single sample, we can use a simple squared loss function to measure the difference between the predicted value $\hat{\mathbf{y}}$ and the ground truth \mathbf{y} as follows:

$$\ell(\mathbf{y}, \hat{\mathbf{y}}) = (\mathbf{y} - \hat{\mathbf{y}})^2.$$

For classification tasks, the neural network needs to tell the classes of given samples. Instead of directly producing a discrete output indicating the predicted labels of a given sample, we usually produce a discrete probability distribution over the labels. Different output layers and loss functions are used depending on whether the prediction is binary or multi-way. Next, we discuss the details in these two scenarios.

Binary Targets

For the binary classification task, we assume that a sample is labeled as either 0 or 1. Then, to perform the prediction, we first need a linear layer to project the input (results from previous layers) into a single value. Following this, a sigmoid function is applied to map this value into the range of 0 to 1, which indicates the probability of the sample being predicted as label 1. In summary,

this process can be modeled as:

$$\hat{y} = \sigma(\mathbf{W}\mathbf{h} + b),$$

where $\mathbf{h} \in \mathbb{R}^{d_{in}}$ and $\mathbf{W} \in \mathbb{R}^{1 \times d_{in}}$. Specifically, \hat{y} denotes the probability of predicting the input sample with label 1 while $1 - \hat{y}$ indicates the probability for label 0. With the output \hat{y} , we can employ the cross-entropy loss to measure the difference between the ground truth and the prediction as:

$$\ell(y, \hat{y}) = -y \cdot \log(\hat{y}) - (1 - y) \cdot \log(1 - \hat{y}).$$

During the inference, an input sample is predicted with label 1 if the predicted $\hat{y} > 0.5$ and with label 0, otherwise.

Categorical Targets

For the n -class classification task, we assume that the ground truth is denoted as integers between 0 and $n - 1$. Thus, we use a one-hot vector $\mathbf{y} \in \{0, 1\}^n$ to indicate the label where $y_i = 1$ indicates that the sample is labeled as $i - 1$. To perform the prediction, we first need a linear layer to transform the input \mathbf{h} to a n -dimensional vector $\mathbf{z} \in \mathbb{R}^n$ as:

$$\mathbf{z} = \mathbf{W}\mathbf{h} + \mathbf{b},$$

where $\mathbf{W} \in \mathbb{R}^{n \times d_{in}}$ and $\mathbf{b} \in \mathbb{R}^n$. We then apply the softmax function to normalize \mathbf{z} into a discrete probability distribution over the classes as:

$$\hat{y}_i = \text{softmax}(\mathbf{z})_i = \frac{\exp(\mathbf{z}_i)}{\sum_j \exp(\mathbf{z}_j)}, i = 1, \dots, n$$

where \mathbf{z}_i denotes the i -th element of the vector \mathbf{z} while \hat{y}_i is the i -th element of the output of the softmax function. Specifically, \hat{y}_i indicates the probability of the input sample being predicted with label $i - 1$. With the predicted $\hat{\mathbf{y}}$, we can employ the cross-entropy loss to measure the difference between the ground truth and the prediction as:

$$\ell(\mathbf{y}, \hat{\mathbf{y}}) = - \sum_{i=0}^{n-1} y_i \log(\hat{y}_i).$$

During the inference, an input sample is predicted with label $i - 1$ if \hat{y}_i is the largest among all output units.

3.3 Convolutional Neural Networks

Convolutional Neural Networks (CNNs) are a popular family of neural networks. They are best known for processing regular grid-like data such as images. They are similar to the feedforward neural networks in many aspects. They also consist of neurons that have trainable weights and bias. Each neuron receives and transforms some information from previous layers. The difference is that some of the neurons in CNNs may have different designs from the ones we introduced for feedforward networks. More specifically, the convolution operation is proposed to design some of the neurons. The layers with the convolution operation are called the convolutional layers. The convolution operation typically only involves a small number of neurons in the previous layers, which enforces sparse connections between layers. Another vital operation in CNNs is the pooling operation, which summarizes the output of nearby neurons as the new output. The layers consist of the pooling operations are called the pooling layers. In this section, we first introduce the convolution operation and convolutional layers, then discuss the pooling layers and finally present an overall framework of CNNs.

3.3.1 The Convolution Operation and Convolutional Layer

In general, the convolution operation is a mathematical operation on two real functions to produce a third function (Widder and Hirschman, 2015). The convolution operation between two functions $f()$ and $g()$ can be defined as:

$$(f * g)(t) = \int_{-\infty}^{\infty} f(\tau)g(t - \tau)d\tau.$$

As an example of motivation, let us consider a continuous signal $f(t)$, where t denotes time and $f(t)$ is the corresponding value at time t . Suppose that the signal is somewhat noisy. To obtain a less noisy signal, we would like to average the value at time t with its nearby values. Furthermore, values corresponding to time that is closer to t may be more similar to that at time t and thus they should contribute more. Hence, we would like to take a weighted average over a few values that are close to time t as its new value. This can be modeled as a convolution operation between the signal $f(t)$ and a weight function $w(c)$, where c represents the closeness to the target t . The smaller c is, the larger the value of $w(c)$ is. The signal after the convolution operation can be represented as:

$$s(t) = (f * w)(t) = \int_{-\infty}^{\infty} f(\tau)w(t - \tau)d\tau.$$

Note that to ensure that the operation does a weighted average, $w(c)$ is constrained to integrate to 1, which makes $w(c)$ a probability density function. In general, the convolution operation is not necessary to be a weighted average operation and the function $w(t)$ does not need to meet these requirements.

In practice, data is usually discrete with fixed intervals. For example, the signal $f(t)$ may only be sampled at integer values of time t . Assuming $f()$ and $w()$ in the previous example are both defined on integer values of time t , then the convolution can be written as:

$$s(t) = (f * w)(t) = \sum_{\tau=-\infty}^{\infty} f(\tau)w(t - \tau).$$

We further consider that in most of the cases, the function $w()$ is only non-zero within a small window. In other words, only local information contributes to the new value of a target position. Suppose that the window size is $2n + 1$, i.e., $w(c) = 0$ for $c < n$ and $c > n$, then the convolution can be further modified as:

$$(f * w)(t) = \sum_{\tau=t-n}^{t+n} f(\tau)w(t - \tau).$$

In the case of neural networks, t can be considered as the indices of the units in the input layer. The function $w()$ is called as a kernel or a filter. The convolution operation can be represented as a sparsely connected graph. The convolutional layers can be explained as sliding the kernel over the input layer and calculating the output correspondingly. An example of the layers consisting of the convolution operation can be found in Figure 3.6.

Example 3.1 Figure 3.6 shows a convolutional layer, where the input and output have the same size. To maintain the size of the output layer, the input layer is padded with two additional units (the dashed circles) with a value 0. The kernel of the convolution operation is shown on the right of the figure. For simplicity, the nonlinear activation function is not shown in the figure. In this example, $n = 1$, and the kernel function is defined only at 3 nearby locations.

In the practical machine learning scenario, we often deal with data with more than one dimension such as images. The convolution operation can be extended to data with high dimensions. For example, for a 2-dimensional image I , the convolution operation can be performed with a 2-dimensional kernel K as:

$$S(i, j) = (I * K)(i, j) = \sum_{\tau=i-n}^{i+n} \sum_{\gamma=j-n}^{j+n} I(\tau, \gamma)K(i - \tau, j - \gamma).$$

Next, we discuss some key properties of the convolutional layer. Without the loss of generality, we consider the convolutional layer for single-dimensional

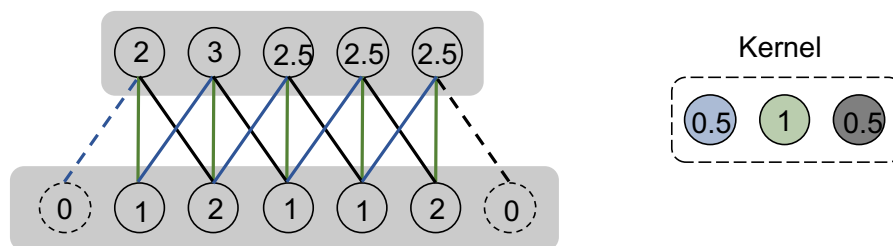

Figure 3.6 An example of a convolutional layer

data. These properties can also be applied to high dimensional data. Convolutional layers mainly have three key properties including *sparse connections*, *parameter sharing* and *equivariant representation*.

Sparse Connection

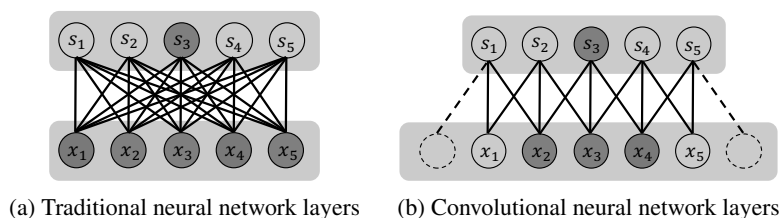

Figure 3.7 Dense and sparse connectivity

In traditional neural network layers, the interactions between the input and the output units can be described by a matrix. Each element of this matrix defines an independent parameter for the interaction between each input unit and each output unit. However, the convolutional layers usually have sparse connections between layers when the kernel is only non-zero on a limited number of input units. A comparison between the traditional neural network layers and the convolutional neural network layers is demonstrated in Figure 3.7. In this figure, we highlight one output unit s_3 and the corresponding input units that affect s_3 . Clearly, in the densely connected layers, a single output unit is affected by all the input units. However, in the convolutional neural network layers, the output unit s_3 is only affected by 3 input units x_2 , x_3 and x_4 , which are called as the *receptive field* of s_3 . One of the major advantages of the sparse connectivity is that it can largely improve the computational efficiency. If there are N input and M output units, there are $N \times M$ parameters in the traditional neural network layers. The time complexity for a single computation

pass of this layer is $O(N \times M)$. While the convolutional layers with the same number of input and output units only have $K \times M$ parameters (we do not consider parameter sharing here, which will be discussed in the next subsection), when its kernel size is K . Correspondingly, the time complexity is reduced to $O(K \times M)$. Typically, the kernel size K is much smaller than the number of input units N . In other words, the computation of convolutional neural networks is much more efficient than that of traditional neural networks.

Parameters Sharing

As aforementioned, there are $K \times M$ parameters in the convolutional layers. However, this number can be further reduced due to *parameter sharing* in the convolutional layers. *Parameter sharing* refers to sharing the same set of parameters when performing the calculation for different output units. In the convolutional layers, the same kernel is used to calculate the values of all the output units. This process naturally leads to parameter sharing. An illustrative example is shown in Figure 3.8, where connections with the same color share the same parameter. In this example, we have a kernel size of 3, which results in 3 parameters. In general, for convolutional layers with the kernel size of K , there are K parameters. Comparing with $N \times M$ parameters in the traditional neural network layers, K is much smaller, and consequently, the requirement for memory is much lower.

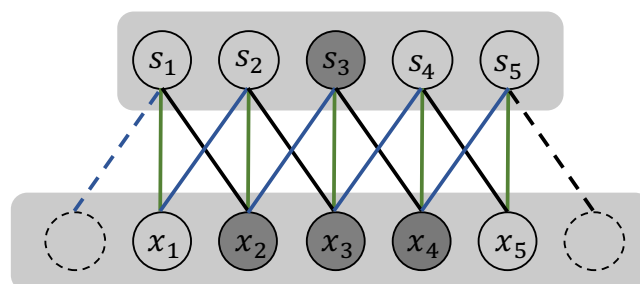

Figure 3.8 Parameter sharing

Equivariant Representation

The parameter sharing mechanism naturally introduces another important property of CNNs, called as *equivariant* to translation. A function is said to be equivariant if the output changes in the same way as the input changes. More specifically, a function $f()$ is equivariant to another function $g()$ if $f(g(x)) = g(f(x))$. In the case of the convolution operation, it is not difficult to verify that

it is equivariant to translation functions such as shifts. For example, if we shift the input units in Figure 3.8 to the right by 1 unit, we can still find the same output pattern that is also shifted to the right by 1 unit. This property is important in many applications where we care more about whether a certain feature appears than where it appears. For example, when recognizing whether an image contains a cat or not, we care whether there are some important features in the image indicating the existence of a cat instead of where these features locate in the image. The property of *equivariant* to translation of CNNs is crucial to their success in the area of image classification (Krizhevsky et al., 2012; He et al., 2016).

3.3.2 Convolutional Layers in Practice

In practice, when we discuss convolution in CNNs, we do not refer to the exact convolution operation as it is defined mathematically. The convolutional layers used in practice differ slightly from the definition. Typically, the input is not only a grid of real values. Instead, it is a grid of vector-valued input. For example, in a colored image consisting of $N \times N$ pixels, three values are associated with each pixel, representing the intensity of red, green and blue, respectively. Each color denotes a *channel* of the input image. Generally, the i -th *channel* of the input image consists of the i -th element of the vectors at all positions of the input. The length of the vector at each position (e.g., pixel in the case of image) is the number of *channels*. Hence, the convolution typically involves three dimensions, while it only “slides” in two dimensions (i.e., it does not slide in the dimension of channels). Furthermore, in typical convolutional layers, multiple distinct kernels are applied in parallel to extract features from the input layer. Consequently, the output layer is also multi-channel, where the results for each kernel correspond to each output channel. Let us consider an input image I with L channels. The convolution operation with P kernels can be formulated as:

$$S(i, j, p) = (I * K_p)(i, j) = \sum_{l=1}^L \sum_{\tau=i-n}^{i+n} \sum_{\gamma=j-n}^{j+n} I(\tau, \gamma, l) K_p(i - \tau, j - \gamma, l), p = 1, \dots, P \quad (3.2)$$

where K_p is the p -th kernel with $(2n + 1)^2 \cdot L$ parameters. The output clearly consists of P channels.

In many cases, to further reduce the computation complexity, we can regularly skip some positions when sliding the kernel over the input. The convolution can be only performed every s positions, where the number s is usually

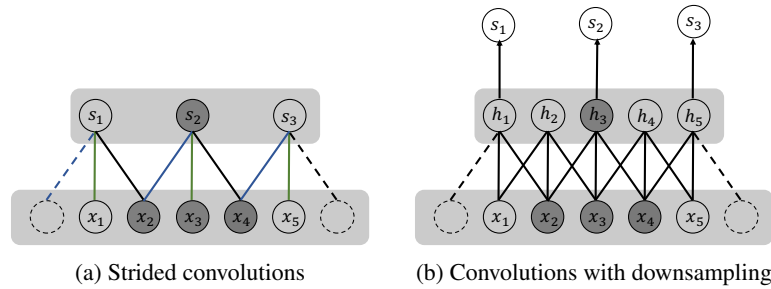

Figure 3.9 Strided convolutions can be viewed as convolutions with downsampling.

called the *stride*. We call the convolutions with stride as strided convolutions. An illustrative example of strided convolutions is illustrated in Figure 3.9a, where the stride is $s = 2$. The strided convolution can be also viewed as a downsampling over the results of the regular convolution as shown in Figure 3.9b. The strided convolution with stride s can be represented as:

$$S(i, j, p) = \sum_{l=1}^L \sum_{\tau=i-n}^{i+n} \sum_{j=\gamma-n}^{\gamma+n} I(\tau, \gamma, l) K_p((i-1) \cdot s + 1 - \tau, (j-1) \cdot s + 1 - \gamma, l).$$

When stride is $s = 1$, the strided convolution operation is equivalent to the non-strided convolution operation as described in Eq. (3.2). As mentioned before, zero padding is usually applied to the input to maintain the size of the output. The size of padding, the size of receptive field (or the size of kernel) and the stride determine the size of the output when the input size is fixed. More specifically, consider a 1-D input with size N . Suppose that the padding size is Q , the size of the receptive field is F and the size of stride is s , the size of the output O can be calculated with the following formulation:

$$O = \frac{N - F + 2Q}{s} + 1. \tag{3.3}$$

Example 3.2 The input size of the strided convolution shown in Figure 3.9a is $N = 5$. Its kernel size is $F = 3$. Clearly, the size of zero-padding is $Q = 1$. Together with stride $s = 2$, we can calculate the output size using Eq. (3.3):

$$O = \frac{N - F + 2Q}{s} + 1 = \frac{5 - 3 + 2 \times 1}{2} + 1 = 3.$$

3.3.3 Non-linear Activation Layer

Similar to feedforward neural networks, nonlinear activation is applied to every unit after the convolution operation. The activation function widely used in CNNs is the ReLU. The process of applying the non-linear activation is also called the *detector* stage or the *detector* layer.

3.3.4 Pooling Layer

A *pooling* layer is usually followed after the convolution layer and the detector layer. The pooling function summarizes the statistic of a local neighborhood to denote this neighborhood in the resulting output. Hence, the width and height of the data is reduced after the pooling layer. However, the depth (the number of channels) of the data does not change. The commonly used pooling operations include max pooling and average pooling as demonstrated in Figure 3.10. These pooling operations take a 2×2 local neighborhood as input and produce a single value based on them. As the names indicate, the max pooling operation takes the maximum value in the local neighborhood as the output while the average pooling takes the average value of the local neighborhood as its output.

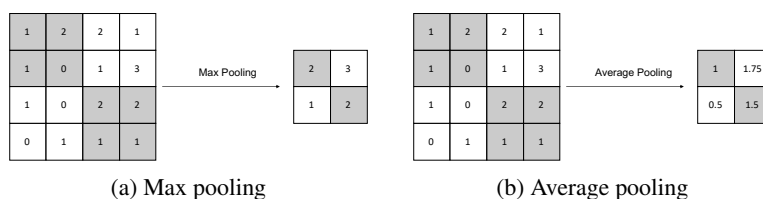

Figure 3.10 Pooling methods in CNNs

3.3.5 An Overall CNN Framework

With the convolution and pooling operations introduced, we now introduce an overall framework of convolutional neural networks with classification as the downstream task. As shown in Figure 3.11, the overall framework for classification can be roughly split into two components – the feature extraction component and the classification component. The feature extraction component, which consists of convolution and pooling layers, extracts features from the input. While the classification component is built upon fully connected

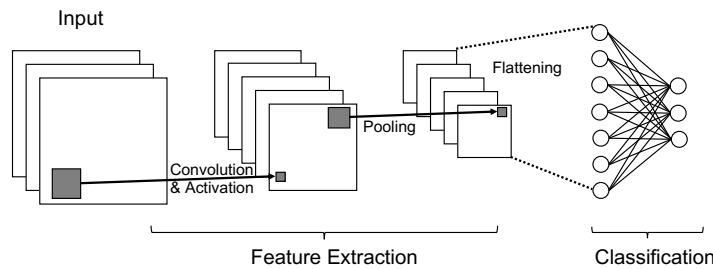

Figure 3.11 An overall framework of convolutional neural networks

feedforward neural networks. A flattening operation connects these two components. It flattens the feature matrices in multiple channels extracted by the feature extraction component to a single feature vector, which is served as the input to the classification component. Note that in Figure 3.11, only a single convolutional layer, and a single pooling layer are illustrated. However, in practice, we usually stack multiple convolutional and pooling layers. Similarly, in the classification component, the feedforward neural networks can consist of multiple fully connected layers.

3.4 Recurrent Neural Networks

Many tasks, such as speech recognition, machine translation, and sentiment classification, need to handle sequential data, where each data sample is represented as a sequence of values. Given a sentence (a sequence of words) in one language, machine translation aims to translate it into another language. Thus, both the input and output are sequences. Sentiment classification predicts the sentiment of a given sentence or document where the input is a sequence, and the output is a value to indicate the sentiment class. We may try to use standard neural network models to deal with sequential data, where each element in the sequence can be viewed as an input unit in the input layer. However, this strategy is not sufficient for sequential data due to two main reasons. First, standard network models often have fixed input and output size; however, sequences (either input or output) can have different lengths for different data samples. Second and more importantly, standard network models do not share parameters to deal with input from different positions of the sequence. For example, in language-related tasks, given two sentences of “I went to the Yellow Stone National park last summer” and “Last summer, I went to the Yellow Stone Na-

tional park”, we expect the model to figure out that the time is “last summer” in both sentences, although it appears in different positions of the sentences. A natural way to achieve this is the idea of parameter sharing as similar to CNNs. The recurrent neural networks (RNNs) have been introduced to solve these two challenges. RNNs are to recurrently apply the same functions to each element of the sequence one by one. Since all positions in the sequence are processed using the same functions, parameter sharing is naturally realized among different positions. Meanwhile, the same functions can be repeatedly applied regardless of the length of the sequence, which can inherently handle sequences with varied lengths.

3.4.1 The Architecture of Traditional RNNs

A sequence with the length n can be denoted as $(\mathbf{x}^{(1)}, \mathbf{x}^{(2)}, \dots, \mathbf{x}^{(n)})$. As shown in Figure 3.12, the traditional RNN model takes one element of the sequence at a time and processes it with a block of neural networks. The block of neural networks often takes not only the element but also the information flowed from the previous block as input. As a result, the information in the early positions of the sequence can flow through the entire sequence. The blocks of neural networks are identical. The RNN model in Figure 3.12 has an output $\mathbf{y}^{(i)}$ at each position i , which is not mandatory for RNN models.

The block of neural networks has two inputs and also produces two outputs. We use $\mathbf{y}^{(i)}$ to denote the output and $\mathbf{h}^{(i)}$ to denote the information flowing to the next position. To process the first element, $\mathbf{h}^{(0)}$ is often initialized as $\mathbf{0}$. The procedure for dealing with the i -th element can be formulated as:

$$\begin{aligned}\mathbf{h}^{(i)} &= \alpha_h(\mathbf{W}_{hh} \cdot \mathbf{h}^{(i-1)} + \mathbf{W}_{hx} \mathbf{x}^{(i-1)} + \mathbf{b}_h) \\ \mathbf{y}^{(i)} &= \alpha_y(\mathbf{W}_{yh} \mathbf{h}^{(i)} + \mathbf{b}_y),\end{aligned}$$

where \mathbf{W}_{hh} , \mathbf{W}_{hx} , and \mathbf{W}_{yh} are the matrices to perform linear transformations; \mathbf{b}_h and \mathbf{b}_y are the bias terms; and $\alpha_h()$ and $\alpha_y()$ are two activation functions.

When dealing with sequential data, it is crucial to capture the long-term dependency in the sequence. For example, in language modeling, two words that appear far away in the sentence can be tightly related. However, it turns out that the traditional RNN model is not good at capturing long-term dependency. The main issue is that the gradients propagated over many stages tend to either vanish or explode. Both phenomena cause problems for the training procedure. The gradient explosion will damage the optimization process, while the vanishing gradient makes the guidance information in the later positions challenging to affect the computations in the earlier positions. To solve these issues, gated RNN models have been proposed. The Long short-term

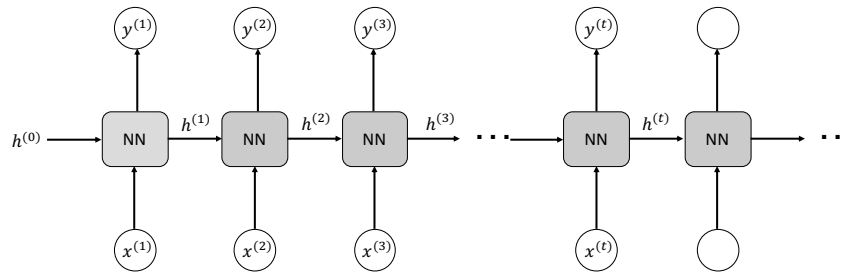

Figure 3.12 The architecture of traditional RNNs

memory (LSTM) (Hochreiter and Schmidhuber, 1997) and gated recurrent unit (GRU) (Cho et al., 2014a) are two representative gated RNN models.

3.4.2 Long Short-Term Memory

The overall structure of the LSTM is the same as that of the traditional RNN model. It also has the chain structure with identical neural network blocks applying to the elements of the sequence. The key difference is that a set of gating units are utilized to control the information flow in LSTM. As shown in Figure 3.13, the information flowing through consecutive positions in a sequence includes the *cell state* $C^{(t-1)}$ and the *hidden state* $h^{(t-1)}$. The cell state serves as the information from the previous states that are propagated to the next position, and the hidden state helps decide how the information should be propagated. The hidden state $h^{(t)}$ also serves as the output of this position if necessary e.g., in sequence to sequence applications .

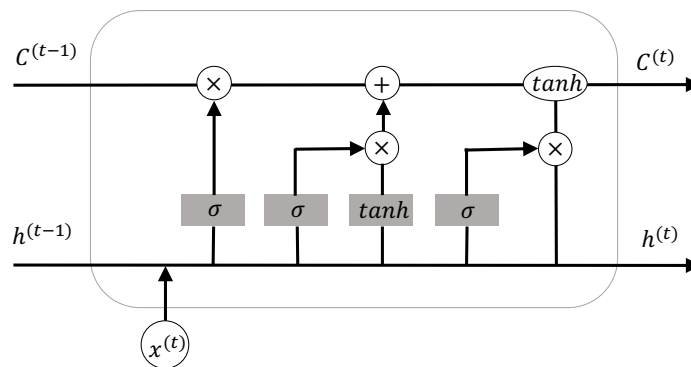

Figure 3.13 A block of LSTM

The first step of the LSTM is to decide what information from previous cell state we are going to discard. The decision is made by a *forget gate*. The forget gate considers the previous hidden state $\mathbf{h}^{(t-1)}$ and the new input $\mathbf{x}^{(t)}$ and outputs a value between 0 to 1 for each of the elements in the cell state $\mathbf{C}^{(t-1)}$. The corresponding value of each element controls how the information in each element is discarded. The outputs can be summarized as a vector \mathbf{f}_t , which has the same dimension as the cell state $\mathbf{C}^{(t-1)}$. More specifically, the forget gate can be formulated as:

$$\mathbf{f}_t = \sigma(\mathbf{W}_f \cdot \mathbf{x}^{(t)} + \mathbf{U}_f \cdot \mathbf{h}^{(t-1)} + \mathbf{b}_f),$$

where \mathbf{W}_f and \mathbf{U}_f are the parameters, \mathbf{b}_f is the bias term, and $\sigma()$ is the sigmoid activation function, which maps values to the range between 0 and 1.

The next step is to determine what information from the new input $\mathbf{x}^{(t)}$ should be stored in the new cell state. Similar to the *forget gate*, an *input gate* is designed to make the decision. The *input gate* is formulated as:

$$\mathbf{i}_t = \sigma(\mathbf{W}_i \cdot \mathbf{x}^{(t)} + \mathbf{U}_i \cdot \mathbf{h}^{(t-1)} + \mathbf{b}_i).$$

The input information $\mathbf{x}^{(t)}$ is processed by a few layers of neural networks to generate candidate values $\tilde{\mathbf{C}}^{(t)}$, which are used to update the cell state. The process of generating $\tilde{\mathbf{C}}^{(t)}$ is as:

$$\tilde{\mathbf{C}}^{(t)} = \tanh(\mathbf{W}_c \cdot \mathbf{x}^{(t)} + \mathbf{U}_c \cdot \mathbf{h}^{(t-1)} + \mathbf{b}_c).$$

Then, we generate the new cell state $\mathbf{C}^{(t)}$ by combining the old cell state $\mathbf{C}^{(t-1)}$ and the new candidate cell $\tilde{\mathbf{C}}^{(t)}$ as:

$$\mathbf{C}^{(t)} = \mathbf{f}_t \odot \mathbf{C}^{(t-1)} + \mathbf{i}_t \odot \tilde{\mathbf{C}}^{(t)},$$

where the notation \odot denotes the Hadamard product, i.e., element-wise multiplication.

Finally we need to generate the hidden state $\mathbf{h}^{(t)}$, which can flow to the next position and serve as the output for this position at the same time if necessary. The hidden state is based on the updated cell state $\mathbf{C}^{(t)}$ with an *output gate* determining which parts of the cell state to be preserved. The output gate is formulated in the same way as the forget gate and the input gate as:

$$\mathbf{o}_t = \sigma(\mathbf{W}_o \cdot \mathbf{x}^{(t)} + \mathbf{U}_o \cdot \mathbf{h}^{(t-1)} + \mathbf{b}_o).$$

The new hidden state $\mathbf{h}^{(t)}$ is then generated as follows:

$$\mathbf{h}^{(t)} = \mathbf{o}_t \odot \tanh(\mathbf{C}^{(t)}).$$

The entire process of the LSTM is shown in the Figure 3.13 and can be summarized as:

$$\begin{aligned}
 \mathbf{f}_t &= \sigma(\mathbf{W}_f \cdot \mathbf{x}^{(t)} + \mathbf{U}_f \cdot \mathbf{h}^{(t-1)} + \mathbf{b}_f) \\
 \mathbf{i}_t &= \sigma(\mathbf{W}_i \cdot \mathbf{x}^{(t)} + \mathbf{U}_i \cdot \mathbf{h}^{(t-1)} + \mathbf{b}_i) \\
 \mathbf{o}_t &= \sigma(\mathbf{W}_o \cdot \mathbf{x}^{(t)} + \mathbf{U}_o \cdot \mathbf{h}^{(t-1)} + \mathbf{b}_o) \\
 \tilde{\mathbf{C}}^{(t)} &= \tanh(\mathbf{W}_c \cdot \mathbf{x}^{(t)} + \mathbf{U}_c \cdot \mathbf{h}^{(t-1)} + \mathbf{b}_c) \\
 \mathbf{C}^{(t)} &= \mathbf{f}_t \odot \mathbf{C}^{(t-1)} + \mathbf{i}_t \odot \tilde{\mathbf{C}}^{(t)} \\
 \mathbf{h}^{(t)} &= \mathbf{o}_t \odot \tanh(\mathbf{C}^{(t)}).
 \end{aligned} \tag{3.4}$$

For convenience, we summarize the block of neural networks in LSTM for processing the t -th position described in Eq. (3.4) as:

$$\mathbf{C}^{(t)}, \mathbf{h}^{(t)} = \text{LSTM}(\mathbf{x}^{(t)}, \mathbf{C}^{(t-1)}, \mathbf{h}^{(t-1)}). \tag{3.5}$$

3.4.3 Gated Recurrent Unit

The gated recurrent unit (GRU) as shown in Figure 3.14 can be viewed as a variant of the LSTM where the forget gate and the input gate are combined as the *update gate* and the cell state and the hidden state are merged as the same one. These changes lead to a simpler gated RNN model which is formulated as:

$$\begin{aligned}
 \mathbf{z}_t &= \sigma(\mathbf{W}_z \cdot \mathbf{x}^{(t)} + \mathbf{U}_z \cdot \mathbf{h}^{(t-1)} + \mathbf{b}_z) \\
 \mathbf{r}_t &= \sigma(\mathbf{W}_r \cdot \mathbf{x}^{(t)} + \mathbf{U}_r \cdot \mathbf{h}^{(t-1)} + \mathbf{b}_r) \\
 \tilde{\mathbf{h}}^{(t)} &= \tanh(\mathbf{W} \cdot \mathbf{x}^{(t)} + \mathbf{U} \cdot (\mathbf{r}_t \odot \mathbf{h}^{(t-1)}) + \mathbf{b}) \\
 \mathbf{h}^{(t)} &= (\mathbf{1} - \mathbf{z}_t) \odot \tilde{\mathbf{h}}^{(t)} + \mathbf{z}_t \odot \mathbf{h}^{(t-1)},
 \end{aligned} \tag{3.6}$$

where \mathbf{z}_t is the update gate and \mathbf{r}_t is the reset gate. For convenience, we summarize the process in Eq. (3.6) as:

$$\mathbf{h}^{(t)} = \text{GRU}(\mathbf{x}^{(t)}, \mathbf{h}^{(t-1)}). \tag{3.7}$$

3.5 Autoencoders

An autoencoder can be viewed as a neural network that tries to reproduce the input as its output. Specifically, it has an intermediate hidden representation \mathbf{h} , which describes a *code* to denote the input. An autoencoder consists of two

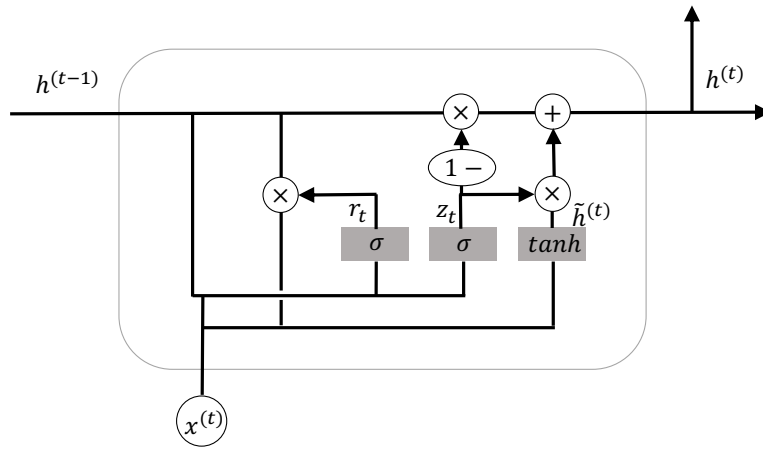

Figure 3.14 A block of GRU

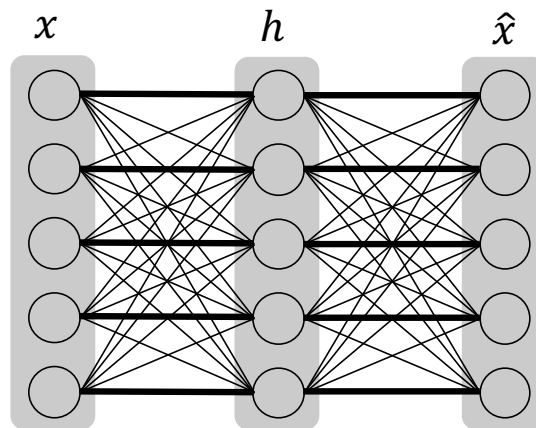

Figure 3.15 An autoencoder memorizes the input to the output. The bold connection indicates the memorization from the input to the output and the other connections are not used (with weights 0) in the autoencoder.

components: 1) an encoder $\mathbf{h} = f(\mathbf{x})$, which encodes the input \mathbf{x} into a code \mathbf{h} , and 2) a decoder which aims to reconstruct \mathbf{x} from the code \mathbf{h} . The decoder can be represented as $\hat{\mathbf{x}} = g(\mathbf{h})$. If an autoencoder works perfectly in reproducing the input, it is not especially useful. Instead, autoencoders are to approximately reproduce the input by including some restrictions. More specifically, they compress necessary information of the input in the hidden code \mathbf{h} to re-

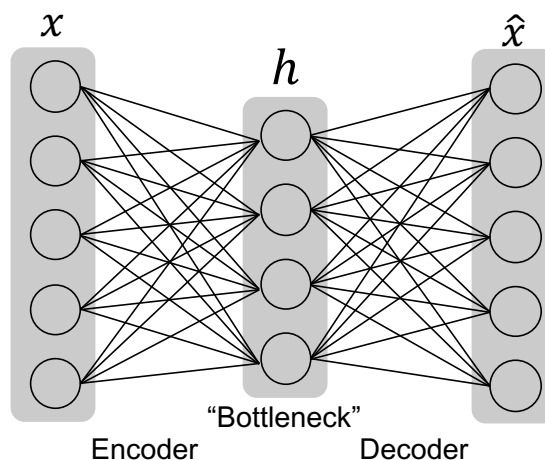

Figure 3.16 A general framework of autoencoder

produce satisfactory output. A general framework of autoencoders is shown in Figure 3.16. The input \mathbf{x} is pushed through a “bottleneck”, which controls the information can be preserved in the code \mathbf{h} . Then, a decoder network utilizes the code \mathbf{h} to output $\hat{\mathbf{x}}$ which reconstructs the input \mathbf{x} . The network of an autoencoder can be trained by minimizing the reconstruction error:

$$\ell(\mathbf{x}, \hat{\mathbf{x}}) = \ell(\mathbf{x}, g(f(\mathbf{x}))), \quad (3.8)$$

where $\ell(\mathbf{x}, \hat{\mathbf{x}})$ measures the difference between \mathbf{x} and $\hat{\mathbf{x}}$. For example, we can use the mean squared error as ℓ . The design of the “bottleneck” is important for autoencoders. Ideally, as shown in Figure 3.15, without a “bottleneck”, an autoencoder can simply learn to memorize the input and pass it through the decoder to reproduce it, which can render the autoencoder useless. There are different ways to design the “bottleneck” (i.e. adding constraints to the autoencoder). A natural way is to constrain the number of dimensions of the code \mathbf{h} , which leads to the *undercomplete autoencoder*. We can also add a regularizer term to discourage memorization between input and output, which leads to *regularized autoencoder*.

3.5.1 Undercomplete Autoencoders

Constraining the number of dimensions in the *code* \mathbf{h} to be smaller than the input \mathbf{x} is a simple and natural way to design the “bottleneck”. An autoen-

coder with code dimension smaller than the input dimension is called an “undercomplete” autoencoder. An illustrative example of an “undercomplete” autoencoder is shown in Figure 3.16, where both the encoder and decoder only contain a single layer of networks and the hidden layer has fewer units than the input layer. By minimizing the reconstruction error, the model can preserve the most important features of the input in the hidden code.

3.5.2 Regularized Autoencoders

We can also make the autoencoder deeper by stacking more layers for both the encoder and decoder. For deep autoencoders, we must be careful about their capacity. Autoencoders may fail to learn anything useful if the encoder and decoder are given too much capacity. To prevent the autoencoder learning an identity function, we can include a regularization term in the loss function of the autoencoder as:

$$\ell(\mathbf{x}, g(f(\mathbf{x}))) + \eta \cdot \Omega(\mathbf{h}), \quad (3.9)$$

where $\Omega(\mathbf{h})$ is the regularization term applied to code \mathbf{h} and η is a hyperparameter controlling the impact of the regularization term.

In (Olshausen and Field, 1997), L_1 norm of the code \mathbf{h} is adopted as the regularization term as follows:

$$\Omega(\mathbf{h}) = \|\mathbf{h}\|_1. \quad (3.10)$$

The L_1 norm based regularization term enforces the code \mathbf{h} to be sparse. In this case, the autoencoder is also named as a *sparse autoencoder*.

Another way to enforce the sparsity in the code is to constraint the neurons in the code \mathbf{h} to be inactive most of the time. Here by “inactive”, we mean that the value of a neuron in \mathbf{h} is in a low level. We use \mathbf{h} to denote the hidden code so far, which doesn’t explicitly show what input leads to this code. Hence, to explicitly express the relation, for a given input \mathbf{x} , we use $\mathbf{h}(\mathbf{x})$ to denote its code learned by the autoencoder. Then, the average hidden code over a set of samples $\{\mathbf{x}_{(i)}\}_{i=1}^m$ is as:

$$\bar{\mathbf{h}} = \frac{1}{m} \sum_{i=1}^m \mathbf{h}(\mathbf{x}_{(i)}). \quad (3.11)$$

Then, we would like to enforce each element in the hidden code to be close to a small value ρ . For example, ρ could be set to 0.05. In (Ng *et al.*, n.d.), each element in the hidden code is treated as a Bernoulli random variable with its corresponding value in $\bar{\mathbf{h}}$ as mean. These random variables are constraint to be

close to the Bernoulli random variable with ρ as mean by KL-divergence as follows:

$$\Omega(\mathbf{h}) = \sum_j \left(\rho \log \frac{\rho}{\bar{\mathbf{h}}[j]} + (1 - \rho) \log \frac{1 - \rho}{1 - \bar{\mathbf{h}}[j]} \right). \quad (3.12)$$

The autoencoder with the regularization term in Eq. (3.12) can also be called *sparse autoencoder*. While the regularization term can be applied to *under-complete autoencoder*, it can also work alone to serve as the “bottleneck”. With the regularization terms, the hidden code \mathbf{h} is not necessary to have a smaller dimension than the input.

3.6 Training Deep Neural Networks

In this section, we discuss the training procedure of deep neural networks. We briefly introduce gradient descent and its variants, which are popular approaches to train neural networks. We then detail the backpropagation algorithm, which is an efficient dynamic algorithm to calculate the gradients of the parameters of the neural networks.

3.6.1 Training with Gradient Descent

To train the deep learning models, we need to minimize a loss function \mathcal{L} with respect to the parameters we want to learn. Generally, we denote the loss function as $\mathcal{L}(\mathbf{W})$ where \mathbf{W} denotes all parameters needed to be optimized. Gradient descent and its variants are commonly adopted to minimize the loss function in deep learning. Gradient descent (Cauchy, n.d.) is a first-order iterative optimization algorithm. At each iteration, we update the parameters \mathbf{W} by taking a step towards the direction of the negative gradient as follows:

$$\mathbf{W}' = \mathbf{W} - \eta \cdot \nabla_{\mathbf{W}} \mathcal{L}(\mathbf{W}), \quad (3.13)$$

where $\nabla_{\mathbf{W}} \mathcal{L}(\mathbf{W})$ denotes the gradient, and η is the learning rate, which is a positive scalar determining how much we want to go towards this direction. The learning rate η is commonly fixed to a small constant in deep learning.

The loss function is usually a summation of penalty over a set of training samples. Therefore, we write the loss function as follows:

$$\mathcal{L}(\mathbf{W}) = \sum_{i=1}^{N_s} \mathcal{L}_i(\mathbf{W}), \quad (3.14)$$

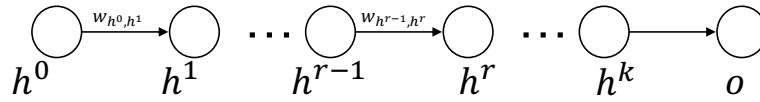

Figure 3.17 A sequence of neurons from consecutive layers

where $\mathcal{L}_i(\mathbf{W})$ is the loss for the i -th sample and N_s denotes the number of samples. In many cases, directly calculating $\nabla_{\mathbf{W}}\mathcal{L}(\mathbf{W})$ over all samples could be both space and time expensive. This where mini-batch gradient descent comes to rescue and is very popular in training deep neural networks. Instead of evaluating the gradient over all training samples, the mini-batch gradient descent method draws a small batch of samples out of the training data and uses them to estimate the gradient. This estimated gradient is then utilized to update the parameters. Specifically, the gradient can be estimated as $\sum_{j \in \mathcal{M}} \nabla_{\mathbf{W}}\mathcal{L}_j(\mathbf{W})$, where \mathcal{M} denotes the set of samples in the minibatch. Other variants of gradient descent have also been developed to train deep neural networks such as Adagrad (Duchi et al., 2011), Adadelata (Zeiler, 2012), and Adam (Kingma and Ba, 2014). They typically have a better convergence than the standard gradient descent methods.

3.6.2 Backpropagation

One crucial step to perform gradient-based optimization is to calculate the gradients with respect to all the parameters. The Backpropagation algorithm provides an efficient way to calculate the gradients using dynamic programming. It consists of two phases: 1) *Forward Phase*: In this phase, the inputs are fed into the deep model and pass through the layers, and the outputs are calculated using the current set of parameters, which are then used to evaluate the value of the loss function; and 2) *Backward Phase*: The goal of this phase is to calculate the gradients of the loss function with respect to the parameters. According to the chain rule, the gradients for all the parameters can be calculated dynamically in a backward direction, starting from the output layer. Next, we detail the backward pass.

Figure 3.17 illustrates a sequence of connected neural units h^0, h^1, \dots, h^k, o from different layers where h^i denotes a unit from the i -th layer with h^0 from the input layer and o from the output layer. Assuming that this is the only path going through the edge (h^{r-1}, h^r) , we can calculate the derivative using the

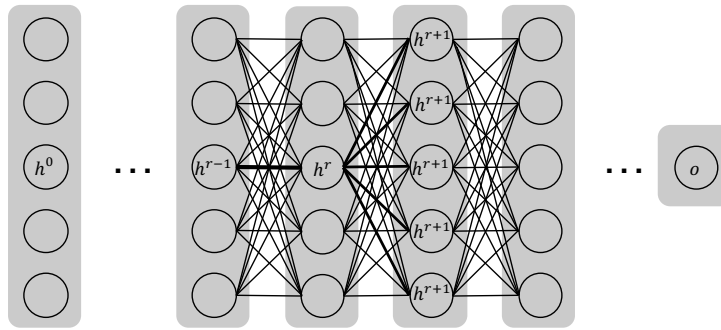

Figure 3.18 Decomposition of paths

chain rule as follows:

$$\frac{\partial \mathcal{L}}{\partial w_{(h^{r-1}, h^r)}} = \frac{\partial \mathcal{L}}{\partial o} \cdot \left[\frac{\partial o}{\partial h^k} \prod_{i=r}^{k-1} \frac{\partial h^{i+1}}{\partial h^i} \right] \cdot \frac{\partial h^r}{\partial w_{(h^{r-1}, h^r)}} \quad \forall r \in 1 \dots k, \quad (3.15)$$

where $w_{(h^{r-1}, h^r)}$ denotes the parameter between the neural units h^{r-1} and h^r .

In multi-layer neural networks, we often have several paths going through the edge (h^{r-1}, h^r) . Hence, we need to sum up the gradients calculated through different paths as follows:

$$\frac{\partial \mathcal{L}}{\partial w_{(h^{r-1}, h^r)}} = \frac{\partial \mathcal{L}}{\partial o} \cdot \underbrace{\left[\sum_{[h^r, h^{r+1}, \dots, h^k, o] \in \mathcal{P}} \frac{\partial o}{\partial h^k} \prod_{i=r}^{k-1} \frac{\partial h^{i+1}}{\partial h^i} \right]}_{\text{Backpropagation computes } \Delta(h^r, o) = \frac{\partial \mathcal{L}}{\partial h^r}}, \quad (3.16)$$

where \mathcal{P} denotes the set of paths starting from h^r to o , which can be extended to pass the edge (h^{r-1}, h^r) . There are two parts on the right hand side of Eq. (3.16), where the second part is trouble-free (will be discussed later) to calculate while the first part (annotated as $\Delta(h^r, o)$) can be calculated recursively. Next, we discuss how to recursively evaluate the first term. Specifically, we have

$$\begin{aligned} \Delta(h^r, o) &= \frac{\partial \mathcal{L}}{\partial o} \cdot \left[\sum_{[h^r, h^{r+1}, \dots, h^k, o] \in \mathcal{P}} \frac{\partial o}{\partial h^k} \prod_{i=r}^{k-1} \frac{\partial h^{i+1}}{\partial h^i} \right] \\ &= \frac{\partial \mathcal{L}}{\partial o} \cdot \left[\sum_{[h^r, h^{r+1}, \dots, h^k, o] \in \mathcal{P}} \frac{\partial o}{\partial h^k} \prod_{i=r+1}^{k-1} \frac{\partial h^{i+1}}{\partial h^i} \cdot \frac{\partial h^{r+1}}{\partial h^r} \right]. \end{aligned} \quad (3.17)$$

As shown in Figure 3.18, we can decompose any path $P \in \mathcal{P}$ into two parts –

the edge (h^r, h^{r+1}) and the remaining path from h^{r+1} to o . Then, we can categorize the paths in \mathcal{P} using the edge (h^r, h^{r+1}) . Specifically, we denote the set of paths in \mathcal{P} that share the same edge (h^r, h^{r+1}) as \mathcal{P}_{r+1} . As all paths in \mathcal{P}_{r+1} share the same first edge (h^r, h^{r+1}) , any path in \mathcal{P}_{r+1} can be characterized by the remaining path (i.e., the path from h^{r+1} to o) besides the first edge. We denote the set of the remaining paths as \mathcal{P}'_{r+1} . Then, we can continue to simplify Eq.(3.17) as follows:

$$\begin{aligned} \Delta(h^r, o) &= \frac{\partial \mathcal{L}}{\partial o} \cdot \left[\sum_{(h^r, h^{r+1}) \in \mathcal{E}} \frac{\partial h^{r+1}}{\partial h^r} \cdot \left[\sum_{[h^{r+1}, \dots, h_k, o] \in \mathcal{P}'_{r+1}} \frac{\partial o}{\partial h_k} \prod_{i=r+1}^{k-1} \frac{\partial h^{i+1}}{\partial h^i} \right] \right] \\ &= \sum_{(h^r, h^{r+1}) \in \mathcal{E}} \frac{\partial h^{r+1}}{\partial h^r} \cdot \frac{\partial \mathcal{L}}{\partial o} \cdot \left[\sum_{[h^{r+1}, \dots, h_k, o] \in \mathcal{P}'_{r+1}} \frac{\partial o}{\partial h_k} \prod_{i=r+1}^{k-1} \frac{\partial h^{i+1}}{\partial h^i} \right] \\ &= \sum_{(h^r, h^{r+1}) \in \mathcal{E}} \frac{\partial h^{r+1}}{\partial h^r} \cdot \Delta(h^{r+1}, o), \end{aligned} \quad (3.18)$$

where \mathcal{E} denotes the set containing all existing edges pointing from the unit h^r to a unit h^{r+1} from the $(r + 1)$ -th layer. Note that, as shown in Figure 3.18, any unit in the $(r + 1)$ -th layer is connected to h^r , hence all units from the $(r + 1)$ -th layer are involved in the first summation in Eq. (3.18). Since each h^{r+1} is from the later layer than h^r , $\Delta(h^{r+1}, o)$ has been evaluated during the previous backpropagation process and can be directly used. We still need to compute $\frac{\partial h^{r+1}}{\partial h^r}$ to complete evaluating Eq. (3.18). To evaluate $\frac{\partial h^{r+1}}{\partial h^r}$, we need to take the activation function into consideration. Let a^{r+1} denote the values of unit h^{r+1} right before the activation function $\alpha()$, that is $h^{r+1} = \alpha(a^{r+1})$. Then, we can use the chain rule to evaluate $\frac{\partial h^{r+1}}{\partial h^r}$ as follows:

$$\frac{\partial h^{r+1}}{\partial h^r} = \frac{\partial \alpha(a^{r+1})}{\partial a^{r+1}} = \frac{\partial \alpha(a^{r+1})}{\partial a^{r+1}} \cdot \frac{\partial a^{r+1}}{\partial h^r} = \alpha'(a^{r+1}) \cdot w_{(h^r, h^{r+1})}, \quad (3.19)$$

where $w_{(h^r, h^{r+1})}$ is the parameter between the two units h^r and h^{r+1} . Then, we can rewrite $\Delta(h^r, o)$ as follows:

$$\Delta(h^r, o) = \sum_{(h^r, h^{r+1}) \in \mathcal{E}} \alpha'(a^{r+1}) \cdot w_{(h^r, h^{r+1})} \cdot \Delta(h^{r+1}, o). \quad (3.20)$$

Now, we return to evaluate the second part of Eq. (3.17) as follows:

$$\frac{\partial h^r}{\partial w_{(h^{r-1}, h^r)}} = \alpha'(a^r) \cdot h^{r-1}. \quad (3.21)$$

With Eq. (3.20) and Eq. (3.21), we can now efficiently evaluate Eq. (3.16) recursively.

3.6.3 Preventing Overfitting

Deep neural networks can easily overfit to the training data due to its extremely high model capacity. In this section, we introduce some practical techniques to prevent neural networks from overfitting.

Weight Regularization

A common technique to prevent models from overfitting in machine learning is to include a regularization term on model parameters into the loss function. The regularization term constrains the model parameters to be relatively small that generally enables the model to generalize better. Two commonly adopted regularizers are the L_1 and L_2 norm of the model parameters.

Dropout

Dropout is an effective technique to prevent overfitting (Srivastava et al., 2014). The idea of dropout is to randomly ignore some units in the networks during each batch of the training procedure. There is a hyper-parameter called *dropout rate* p controlling the probability of neglecting each unit. Then, in each iteration, we randomly determine which neurons in the network to drop according to the probability p . Instead of using the entire network, the remaining neurons and network structure are then used to perform the calculation and prediction for this iteration. Note that the dropout technique is usually only utilized in the training procedure; in other words, the full network is always used to perform predictions during the inference procedure.

Batch Normalization

Batch normalization (Ioffe and Szegedy, 2015) was initially introduced to solve the problem of the internal covariate shift. It can also help mitigate overfitting. Batch normalization is to normalize the activation from the previous layer before feeding them into the next layer. Specifically, during the training procedure, if a mini-batch training procedure is adopted, this normalization is conducted by subtracting the batch mean and dividing the batch standard deviation. During the inference stage, we use the population statistics to perform the normalization.

3.7 Conclusion

In this chapter, we introduced a variety of basic deep architectures, including feedforward networks, convolutional neural networks, recurrent neural networks, and autoencoders. We then discussed gradient-based methods and the

backpropagation algorithm for training deep modes. Finally, we reviewed some practical techniques to prevent overfitting during the training procedure of these architectures.

3.8 Further Reading

To better understand deep learning and neural networks, proper knowledge on linear algebra, probability and optimization is necessary. There are quite a few high quality books on these topics such as *Linear algebra* (Hoffman and Kunze, n.d.), *An Introduction to Probability Theory and Its Applications* (Feller, 1957), *Convex Optimization* (Boyd et al., 2004) and *Linear Algebra and Optimization for Machine Learning* (Aggarwal, 2018). These topics are also usually briefly introduced in machine learning books such as *Pattern Recognition and Machine Learning* (Bishop, 2006). There are dedicated books providing more detailed knowledge and content on deep neural networks such as *Deep Learning* (Goodfellow et al., 2016) and *Neural Networks and Deep Learning: A Textbook* (Aggarwal, 2018). In addition, various deep neural network models can be easily constructed with libraries and platforms such as Tensorflow (Abadi et al., 2015) and Pytorch (Paszke et al., 2017).

PART TWO

METHODS

4

Graph Embedding

4.1 Introduction

Graph embedding aims to map each node in a given graph into a low-dimensional vector representation (or commonly known as node embedding) that typically preserves some key information of the node in the original graph. A node in a graph can be viewed from two domains: 1) the original graph domain, where nodes are connected via edges (or the graph structure); and 2) the embedding domain, where each node is represented as a continuous vector. Thus, from this two-domain perspective, graph embedding targets on mapping each node from the graph domain to the embedding domain so that the information in the graph domain can be preserved in the embedding domain. Two key questions naturally arise: 1) what information to preserve? and 2) how to preserve this information? Different graph embedding algorithms often provide different answers to these two questions. For the first question, many types of information have been investigated such as node's neighborhood information (Perozzi et al., 2014; Tang et al., 2015; Grover and Leskovec, 2016), node's structural role (Ribeiro et al., 2017), node status (Ma et al., 2017; Lai et al., 2017; Gu et al., 2018) and community information (Wang et al., 2017c). There are various methods proposed to answer the second question. While the technical details of these methods vary, most of them share the same idea, which is to reconstruct the graph domain information to be preserved by using the node representations in the embedding domain. The intuition is those good node representations should be able to reconstruct the information we desire to preserve. Therefore, the mapping can be learned by minimizing the reconstruction error. We illustrate an overall framework in Figure 4.1 to summarize the general process of graph embedding. As shown in Figure 4.1, there are four key components in the general framework as:

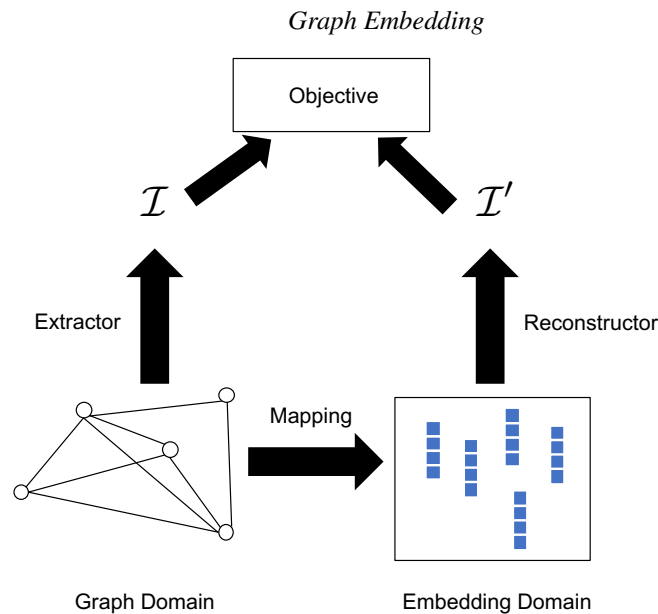

Figure 4.1 A general framework for graph embedding

- A mapping function, which maps the node from the graph domain to the embedding domain.
- An information extractor, which extracts the key information \mathcal{I} we want to preserve from the graph domain.
- A reconstructor to construct the extracted graph information \mathcal{I} using the embeddings from the embedding domain. Note that the reconstructed information is denoted as \mathcal{I}' as shown in Figure 4.1.
- An objective based on the extracted information \mathcal{I} and the reconstructed information \mathcal{I}' . Typically, we optimize the objective to learn all parameters involved in the mapping and/or reconstructor.

In this chapter, we introduce representative graph embedding methods, which preserve different types of information in the graph domain, based on the general framework in Figure 4.1. Furthermore, we introduce graph embedding algorithms designed specifically for complex graphs, including heterogeneous graphs, bipartite graphs, multi-dimensional graphs, signed graphs, hypergraphs, and dynamic graphs.

4.2 Graph Embedding on Simple Graphs

In this section, we introduce graph embedding algorithms for simple graphs that are static, undirected, unsigned, and homogeneous, as introduced in Chapter 2.2. We organize algorithms according to the information they attempt to preserve, including node co-occurrence, structural role, node status, and community structure.

4.2.1 Preserving Node Co-occurrence

One of the most popular ways to extract node co-occurrence in a graph is via performing random walks. Nodes are considered similar to each other if they tend to co-occur in these random walks. The mapping function is optimized so that the learned node representations can reconstruct the “similarity” extracted from random walks. One representative network embedding algorithm preserving node co-occurrence is DeepWalk (Perozzi et al., 2014). Next, we first introduce the DeepWalk algorithm under the general framework by detailing its mapping function, extractor, reconstructor, and objective. Then, we present more node co-occurrence preserving algorithms such as node2vec (Grover and Leskovec, 2016) and LINE (Tang et al., 2015).

Mapping Function

A direct way to define the mapping function $f(v_i)$ is using a look-up table. It means that we retrieve node v_i 's embedding \mathbf{u}_i given its index i . Specifically, the mapping function is implemented as:

$$f(v_i) = \mathbf{u}_i = \mathbf{e}_i^\top \mathbf{W}, \quad (4.1)$$

where $\mathbf{e}_i \in \{0, 1\}^N$ with $N = |\mathcal{V}|$ is the one-hot encoding of the node v_i . In particular, \mathbf{e}_i contains a single element $\mathbf{e}_i[i] = 1$ and all other elements are 0. $\mathbf{W}^{N \times d}$ is the embedding parameters to be learned where d is the dimension of the embedding. The i -th row of the matrix \mathbf{W} denotes the representation (or the embedding) of node v_i . Hence, the number of parameters in the mapping function is $N \times d$.

Random Walk Based Co-occurrence Extractor

Given a starting node $v^{(0)}$ in a graph \mathcal{G} , we randomly walk to one of its neighbors. We repeat this process from the node until T nodes are visited. This random sequence of visited nodes is a random walk of length T on the graph. We formally define a random walk as follows.

Definition 4.1 (Random Walk) Let $\mathcal{G} = \{\mathcal{V}, \mathcal{E}\}$ denote a connected graph. We now consider a random walk starting at node $v^{(0)} \in \mathcal{V}$ on the graph G . Assume that at the t -th step of the random walk, we are at node $v^{(t)}$ and then we proceed the random walk by choosing the next node according to the following probability:

$$p(v^{(t+1)}|v^{(t)}) = \begin{cases} \frac{1}{d(v^{(t)})}, & \text{if } v^{(t+1)} \in \mathcal{N}(v^{(t)}) \\ 0, & \text{otherwise,} \end{cases}$$

where $d(v^{(t)})$ denotes the degree of node $v^{(t)}$ and $\mathcal{N}(v^{(t)})$ is the set of neighbors of $v^{(t)}$. In other words, the next node is randomly selected from the neighbors of the current node following a uniform distribution.

We use a random walk generator to summarize the above process as below:

$$\mathcal{W} = \text{RW}(\mathcal{G}, v^{(0)}, T),$$

where $\mathcal{W} = (v^{(0)}, \dots, v^{(T-1)})$ denotes the generated random walk where $v^{(0)}$ is the starting node and T is the length of the random walk.

Random walks have been employed as a similarity measure in various tasks such as content recommendation (Fouss et al., 2007) and community detection (Andersen et al., 2006). In DeepWalk, a set of short random walks is generated from a given graph, and then node co-occurrence is extracted from these random walks. Next, we detail the process of generating the set of random walks and extracting co-occurrence from them.

To generate random walks that can capture the information of the entire graph, each node is considered as a starting node to generate γ random walks. Therefore, there are $N \cdot \gamma$ random walks in total. This process is shown in Algorithm 1. The input of the algorithm includes a graph \mathcal{G} , the length T of the random walk, and the number of random walks γ for each starting node. From line 4 to line 8 in Algorithm 1, we generate γ random walks for each node in \mathcal{V} and add these random walks to \mathcal{R} . In the end, \mathcal{R} , which consists of $N \cdot \gamma$ generated random walks, is the output of the algorithm.

Algorithm 1: Generating Random Walks

```

1 Input:  $\mathcal{G} = \{\mathcal{V}, \mathcal{E}\}, T, \gamma$ 
2 Output:  $\mathcal{R}$ 
3 Initialization:  $\mathcal{R} \leftarrow \emptyset$ 
4 for  $i$  in  $\text{range}(1, \gamma)$  do
5     for  $v \in \mathcal{V}$  do
6          $\mathcal{W} \leftarrow RW(\mathcal{G}, v^{(0)}, T)$ 
7          $\mathcal{R} \leftarrow \mathcal{R} \cup \{\mathcal{W}\}$ 
8     end
9 end

```

These random walks can be treated as sentences in an “artificial language” where the set of nodes \mathcal{V} is its vocabulary. The Skip-gram algorithm (Mikolov et al., 2013) in language modeling tries to preserve the information of the sentences by capturing the co-occurrence relations between words in these sentences. For a given center word in a sentence, those words within a certain distance w away from the center word are treated as its “context”. Then the center word is considered to be co-occurred with all words in its “context”. The Skip-gram algorithm aims to preserve such co-occurrence information. These concepts are adopted to the random walks to extract co-occurrence relations between nodes (Perozzi et al., 2014). Specifically, we denote the co-occurrence of two nodes as a tuple (v_{con}, v_{cen}) , where v_{cen} denotes the center node and v_{con} indicates one of its context nodes. The process of extracting the co-occurrence relations between nodes from the random walks is shown in Algorithm 2. For each random walk $\mathcal{W} \in \mathcal{R}$, we iterate over the nodes in the random walk (line 5). For each node $v^{(i)}$, we add $(v^{(i-j)}, v^{(i)})$ and $(v^{(i+j)}, v^{(i)})$ into the list of co-occurrence \mathcal{I} for $j = 1, \dots, w$ (from line 6 to line 9). Note that for the cases where $i - j$ or $i + j$ is out of the range of the random walk, we simply ignore them. For a given center node, we treat all its “context” nodes equally regardless of the distance between them. In (Cao et al., 2015), the “context” nodes are treated differently according to their distance to the center node.

Algorithm 2: Extracting Co-occurrence

```

1 Input:  $\mathcal{R}, w$ 
2 Output:  $\mathcal{I}$ 
3 Initialization:  $\mathcal{I} \leftarrow []$ 
4 for  $\mathcal{W}$  in  $\mathcal{R}$  do
5     for  $v^{(i)} \in \mathcal{W}$  do
6         for  $j$  in  $\text{range}(1, w)$  do
7              $\mathcal{I}.\text{append}((v^{(i-j)}, v^{(i)}))$ 
8              $\mathcal{I}.\text{append}((v^{(i+j)}, v^{(i)}))$ 
9         end
10    end
11 end

```

Reconstructor and Objective

With the mapping function and the node co-occurrence information, we discuss the process of reconstructing the co-occurrence information using the representations in the embedding domain. To reconstruct the co-occurrence information, we try to infer the probability of observing the tuples in \mathcal{I} . For any given tuple $(v_{con}, v_{cen}) \in \mathcal{I}$, there are two roles of nodes, i.e., the center node v_{cen} and the context node v_{con} . A node can play both roles, i.e., the center node and the context node of other nodes. Hence, two mapping functions are employed to generate two node representations for each node corresponding to its two roles. They can be formally stated as:

$$\begin{aligned}
 f_{cen}(v_i) &= \mathbf{u}_i = \mathbf{e}_i^\top \mathbf{W}_{cen} \\
 f_{con}(v_i) &= \mathbf{v}_i = \mathbf{e}_i^\top \mathbf{W}_{con}.
 \end{aligned}$$

For a tuple (v_{con}, v_{cen}) , the co-occurrence relation can be explained as observing v_{con} in the context of the center node v_{cen} . With the two mapping functions f_{cen} and f_{con} , the probability of observing v_{con} in the context of v_{cen} can be modeled using a softmax function as follows:

$$p(v_{con}|v_{cen}) = \frac{\exp(f_{con}(v_{con})^\top f_{cen}(v_{cen}))}{\sum_{v \in \mathcal{V}} \exp(f_{con}(v)^\top f_{cen}(v_{cen}))}, \quad (4.2)$$

which can be regarded as the reconstructed information from the embedding domain for the tuple (v_{con}, v_{cen}) . For any given tuple (v_{con}, v_{cen}) , the reconstructor Rec can return the probability in Eq. (4.2) that is summarized as:

$$Rec((v_{con}, v_{cen})) = p(v_{con}|v_{cen}).$$

If we can accurately infer the original graph information of \mathcal{I} from the embedding domain, the extracted information \mathcal{I} can be considered as well-reconstructed. To achieve the goal, the *Rec* function should return high probabilities for extracted tuples in the \mathcal{I} , while low probabilities for randomly generated tuples. We assume that these tuples in the co-occurrence \mathcal{I} are independent to each other as that in the Skip-gram algorithm (Mikolov et al., 2013). Hence, the probability of reconstructing \mathcal{I} can be modeled as follows:

$$\mathcal{I}' = \text{Rec}(\mathcal{I}) = \prod_{(v_{con}, v_{cen}) \in \mathcal{I}} p(v_{con}|v_{cen}), \quad (4.3)$$

There may exist duplicate tuples in \mathcal{I} . To remove these duplicates in Eq. (4.3), we re-formulate it as follows:

$$\prod_{(v_{con}, v_{cen}) \in \text{set}(\mathcal{I})} p(v_{con}|v_{cen})^{\#(v_{con}, v_{cen})}, \quad (4.4)$$

where $\text{set}(\mathcal{I})$ denotes the set of unique tuples in \mathcal{I} without duplicates and $\#(v_{con}, v_{cen})$ is the frequency of tuples (v_{con}, v_{cen}) in \mathcal{I} . Therefore, the tuples that are more frequent in \mathcal{I} contribute more to the overall probability in Eq. (4.4). To ensure better reconstruction, we need to learn the parameters of the mapping functions such that Eq. (4.4) can be maximized. Thus, the node embeddings \mathbf{W}_{con} and \mathbf{W}_{cen} (or parameters of the two mapping functions) can be learned by minimizing the following objective:

$$\mathcal{L}(\mathbf{W}_{con}, \mathbf{W}_{cen}) = - \sum_{(v_{con}, v_{cen}) \in \text{set}(\mathcal{I})} \#(v_{con}, v_{cen}) \cdot \log p(v_{con}|v_{cen}), \quad (4.5)$$

where the objective is the negative logarithm of Eq. (4.4).

Speeding Up the Learning Process

In practice, calculating the probability in Eq. (4.2) is computationally unfeasible due to the summation over all nodes in the denominator. To address this challenge, two main techniques have been employed – one is hierarchical softmax, and the other is negative sampling (Mikolov et al., 2013).

Hierarchical Softmax

In the hierarchical softmax, nodes in a graph \mathcal{G} are assigned to the leaves of a binary tree. A toy example of the binary tree for hierarchical softmax is shown in Figure 4.2 where there are 8 leaf nodes, i.e., there are 8 nodes in the original graph \mathcal{G} . The probability $p(v_{con}|v_{cen})$ can now be modeled through the path to node v_{con} in the binary tree. Given the path to the node v_{con} identified by a sequence of tree nodes $(p^{(0)}, p^{(1)}, \dots, p^{(H)})$ with $p^{(0)} = b_0$ (the root) and

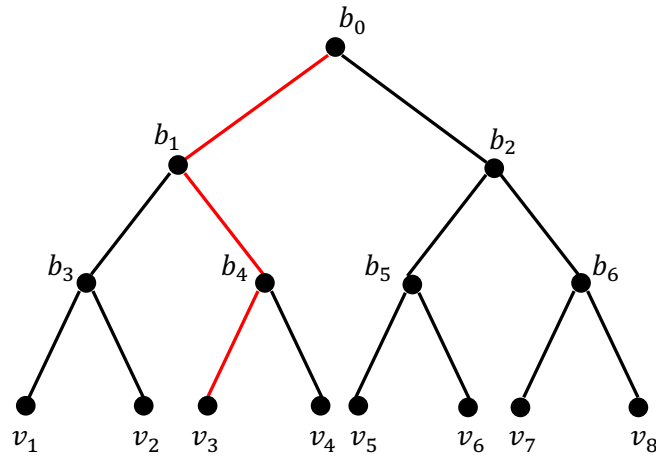

Figure 4.2 An illustrative example of hierarchical softmax. The path to node v_3 is highlighted in red.

$p^{(H)} = v_{con}$, the probability can be obtained as:

$$p(v_{con}|v_{cen}) = \prod_{h=1}^H p_{path}(p^{(h)}|v_{cen}),$$

where $p_{path}(p^{(h)}|v_{cen})$ can be modeled as a binary classifier that takes the center node representation $f(v_{cen})$ as input. Specifically, for each internal node, a binary classifier is built to determine the next node for the path to proceed.

We use the root node b_0 to illustrate the binary classifier where we are calculating the probability $p(v_3|v_8)$ (i.e. $(v_{con}, v_{cen}) = (v_3, v_8)$) for the toy example shown in Figure 4.2. At the root node b_0 , the probability of proceeding to the left node can be computed as:

$$p(left|b_0, v_8) = \sigma(f_b(b_0)^\top f(v_8)),$$

where f_b is a mapping function for the internal nodes, f is the mapping function for the leaf nodes (or nodes in graph \mathcal{G}) and σ is the sigmoid function. Then the probability of the right node at b_0 can be calculated as

$$p(right|b_0, v_8) = 1 - p(left|b_0, v_8) = \sigma(-f_b(b_0)^\top f(v_8)).$$

Hence, we have

$$p_{path}(b_1|v_8) = p(left|b_0, v_8).$$

Note that the embeddings of the internal nodes can be regarded as the parameters of the binary classifiers, and the input of these binary classifiers is the embedding of the center node in (v_{con}, v_{cen}) . By using the hierarchical softmax instead of the conventional softmax in Eq. (4.2), the computational cost can be hugely reduced from $O(|\mathcal{V}|)$ to $O(\log |\mathcal{V}|)$. Note that in the hierarchical softmax, we do not learn two mapping functions for nodes in \mathcal{V} any more. Instead, we learn a mapping function f for nodes in \mathcal{V} (or leaf nodes in the binary tree) and a mapping function f_b for the internal nodes in the binary tree.

Example 4.2 (Hierarchical Softmax) Assume that (v_3, v_8) is a tuple describing co-occurrence information between nodes v_3 and v_8 with v_3 the context node and v_8 the center node in a given graph \mathcal{G} and the binary tree of hierarchical softmax for this graph is shown in Figure 4.2. The probability of observing v_3 in the context of v_8 , i.e., $p(v_3|v_8)$, can be computed as follows:

$$\begin{aligned} p(v_3|v_8) &= p_{path}(b_1|v_8) \cdot p_{path}(b_4|v_8) \cdot p_{path}(v_3|v_8) \\ &= p(left|b_0, v_8) \cdot p(right|b_1, v_8) \cdot p(left|b_4, v_8). \end{aligned}$$

Negative Sampling

Another popular approach to speed up the learning process is negative sampling (Mikolov et al., 2013). It is simplified from Noise Contrastive Estimation (NCE) (Gutmann and Hyvärinen, 2012) that has been shown to approximately maximize the log probability of the softmax. However, our ultimate goal is to learn high quality node representations instead of maximizing the probabilities. It is reasonable to simplify NCE as long as the learned node representations retain good quality. Hence, the following modifications are made to NCE and Negative Sampling are defined as follows. For each tuple (v_{con}, v_{cen}) in \mathcal{I} , we sample k nodes that do not appear in the “context” of the center node v_{cen} to form the negative sample tuples. With these negative sample tuples, we define Negative Sampling for (v_{con}, v_{cen}) by the following objective:

$$\log \sigma(f_{con}(v_{con})^\top f_{cen}(v_{cen})) + \sum_{i=1}^k E_{v_n \sim P_n(v)} \left[\log \sigma(-f_{con}(v_n)^\top f_{cen}(v_{cen})) \right], \quad (4.6)$$

where the probability distribution $P_n(v)$ is the noise distribution to sample the negative tuples that is often set to $P_n(v) \sim d(v)^{3/4}$ as suggested in (Mikolov et al., 2013; Tang et al., 2015). By maximizing Eq. (4.6), the probabilities between the nodes in the true tuples from \mathcal{I} are maximized while these between the sample nodes in the negative tuples are minimized. Thus, it tends to ensure that the learned node representations preserve the co-occurrence information.

The objective in Eq. (4.6) is used to replace $\log p(v_{con}|v_{cen})$ in Eq. (4.5) that results in the following overall objective:

$$\begin{aligned} \mathcal{L}(\mathbf{W}_{con}, \mathbf{W}_{cen}) = & \sum_{(v_{con}, v_{cen}) \in \text{set}(\mathcal{I})} \#(v_{con}, v_{cen}) \cdot (\log \sigma(f_{con}(v_{con})^\top f_{cen}(v_{cen}))) \\ & + \sum_{i=1}^k E_{v_n \sim P_n(v)} [\log \sigma(-f_{con}(v_n)^\top f_{cen}(v_{cen}))]. \end{aligned} \quad (4.7)$$

By using negative sampling instead of the conventional softmax, the computational cost can be hugely reduced from $O(|\mathcal{V}|)$ to $O(k)$.

Training Process in Practice

We have introduced the overall objective function in Eq. (4.5) and two strategies to improve the efficiency of calculating the loss function. The node representations can now be learned by optimizing the objective in Eq. (4.5) (or its alternatives). However, in practice, instead of evaluating the entire objective function over the whole set of \mathcal{I} and performing gradient descent based updates, the learning process is usually done in a batch-wise way. Specifically, after generating each random walk \mathcal{W} , we can extract its corresponding co-occurrence information $\mathcal{I}_{\mathcal{W}}$. Then, we can formulate an objective function based on $\mathcal{I}_{\mathcal{W}}$ and evaluate the gradient based on this objective function to perform the updates for the involved node representations.

Other Co-occurrence Preserving Methods

There are some other methods that aim to preserve co-occurrence information such as node2vec (Grover and Leskovec, 2016) and LINE (second-order) (Tang et al., 2015). They are slightly different from DeepWalk but can still be fitted to the general framework in Figure 4.1. Next, we introduce these methods with the focus on their differences from DeepWalk.

node2vec

node2vec (Grover and Leskovec, 2016) introduces a more flexible way to explore the neighborhood of a given node through the biased-random walk, which is used to replace the random walk in DeepWalk to generate \mathcal{I} . Specifically, a second-order random walk with two parameters p and q is proposed. It is defined as follows:

Definition 4.3 Let $\mathcal{G} = \{\mathcal{V}, \mathcal{E}\}$ denote a connected graph. We consider a random walk starting at node $v^{(0)} \in \mathcal{V}$ in the graph G . Assume that the random walk has just walked from the node $v^{(t-1)}$ to node $v^{(t)}$ and now resides at the

node $v^{(t)}$. The walk needs to decide which node to go for the next step. Instead of choosing $v^{(t+1)}$ uniformly from the neighbors of $v^{(t)}$, a probability to sample is defined based on both $v^{(t)}$ and $v^{(t-1)}$. In particular, an unnormalized “probability” to choose the next node is defined as follows:

$$\alpha_{pq}(v^{(t+1)}|v^{(t-1)}, v^{(t)}) = \begin{cases} \frac{1}{p} & \text{if } \text{dis}(v^{(t-1)}, v^{(t+1)}) = 0 \\ 1 & \text{if } \text{dis}(v^{(t-1)}, v^{(t+1)}) = 1 \\ \frac{1}{q} & \text{if } \text{dis}(v^{(t-1)}, v^{(t+1)}) = 2 \end{cases} \quad (4.8)$$

where $\text{dis}(v^{(t-1)}, v^{(t+1)})$ measures the length of the shortest path between node $v^{(t-1)}$ and $v^{(t+1)}$. The unnormalized “probability” in Eq. (4.8) can then be normalized as a probability to sample the next node $v^{(t+1)}$.

Note that the random walk based on this normalized probability is called second-order random walk as it considers both the previous node $v^{(t-1)}$ and the current node $v^{(t)}$ when deciding the next node $v^{(t+1)}$. The parameter p controls the probability to revisit the node $v^{(t-1)}$ immediately after stepping to node $v^{(t)}$ from node $v^{(t-1)}$. Specifically, a smaller p encourages the random walk to revisit while a larger p ensures the walk to less likely backtrack to visited nodes. The parameter q allows the walk to differentiate the “inward” and “outward” nodes. When $q > 1$, the walk is biased to nodes that are close to node $v^{(t-1)}$, and when $q < 1$, the walk tends to visit nodes that are distant from node $v^{(t-1)}$. Therefore, by controlling the parameters p and q , we can generate random walks with different focuses. After generating the random walks according to the normalized version of the probability in Eq. (4.8), the remaining steps of node2vec are the same as DeepWalk.

LINE

The objective of LINE (Tang et al., 2015) with the second order proximity can be expressed as follows:

$$- \sum_{(v_{con}, v_{cen}) \in \mathcal{E}} (\log \sigma(f_{con}(v_{con})^\top f_{cen}(v_{cen}))) + \sum_{i=1}^k E_{v_n \sim P_n(v)} [\log \sigma(-f_{con}(v_n)^\top f_{cen}(v_{cen}))], \quad (4.9)$$

where \mathcal{E} is the set of edges in the graph \mathcal{G} . Comparing Eq. (4.9) with Eq. (4.7), we can find that the major difference is that LINE adopts \mathcal{E} instead of \mathcal{I} as the information to be reconstructed. In fact, \mathcal{E} can be viewed as a special case of \mathcal{I} where the length of the random walk is set to 1.

A Matrix Factorization View

In (Qiu et al., 2018b), it is shown that these aforementioned network embedding methods can be viewed from a matrix factorization perspective. For example, we have the following theorem for DeepWalk.

Theorem 4.4 ((Qiu et al., 2018b)) *In the matrix form, DeepWalk with negative sampling for a given graph \mathcal{G} is equivalent to factoring the following matrix:*

$$\log \left(\frac{\text{vol}(\mathcal{G})}{T} \left(\sum_{r=1}^T \mathbf{P}^r \right) \mathbf{D}^{-1} \right) - \log(k),$$

where $\mathbf{P} = \mathbf{D}^{-1} \mathbf{A}$ with \mathbf{A} the adjacency matrix of graph \mathcal{G} and \mathbf{D} its corresponding degree matrix, T is the length of random walk, $\text{vol}(\mathcal{G}) = \sum_{i=1}^{|\mathcal{V}|} \sum_{j=1}^{|\mathcal{V}|} \mathbf{A}_{i,j}$ and k is the number of negative samples.

Actually, the matrix factorization form of DeepWalk can be also fitted into the general framework introduced in above. Specifically, the information extractor is

$$\log \left(\frac{\text{vol}(\mathcal{G})}{T} \left(\sum_{r=1}^T \mathbf{P}^r \right) \mathbf{D}^{-1} \right).$$

The mapping function is the same as that introduced for DeepWalk, where we have two mapping functions, $f_{cen}()$ and $f_{con}()$. The parameters for these two mapping functions are \mathbf{W}_{cen} and \mathbf{W}_{con} , which are also the two sets of node representations for the graph \mathcal{G} . The reconstructor, in this case, can be represented in the following form: $\mathbf{W}_{con} \mathbf{W}_{cen}^T$. The objective function can then be represented as follows:

$$\mathcal{L}(\mathbf{W}_{con}, \mathbf{W}_{cen}) = \left\| \log \left(\frac{\text{vol}(\mathcal{G})}{T} \left(\sum_{r=1}^T \mathbf{P}^r \right) \mathbf{D}^{-1} \right) - \log(b) - \mathbf{W}_{con} \mathbf{W}_{cen}^T \right\|_F^2.$$

The embeddings \mathbf{W}_{con} and \mathbf{W}_{cen} can thus be learned by minimizing this objective. Similarly, LINE and node2vec can also be represented in the matrix form (Qiu et al., 2018b).

4.2.2 Preserving Structural Role

Two nodes close to each other in the graph domain (e.g., nodes d and e in Figure 4.3) tend to co-occur in many random walks. Therefore, the co-occurrence preserving methods are likely to learn similar representations for these nodes in the embedding domain. However, in many real-world applications, we want

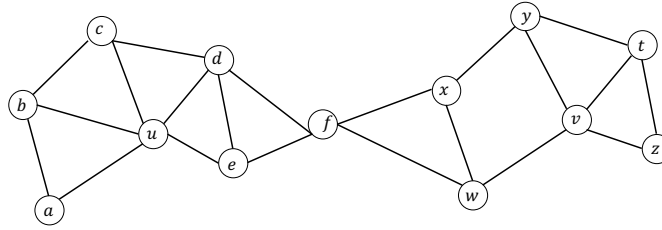

Figure 4.3 An illustration of two nodes that share similar structural role

to embed the nodes u and v in Figure 4.3 to be close in the embedding domain since they share a similar structural role. For example, if we want to differentiate hubs from non-hubs in airport networks, we need to project the hub cities, which are likely to be apart from each other but share a similar structural role, into similar representations. Therefore, it is vital to develop graph embedding methods that can preserve structural roles.

The method `struc2vec` is proposed to learn node representations that can preserve structural identity (Ribeiro et al., 2017). It has the same mapping function as DeepWalk while it extracts structural role similarity from the original graph domain. In particular, a degree-based method is proposed to measure the pairwise structural role similarity, which is then adopted to build a new graph. Therefore, the edge in the new graph denotes structural role similarity. Next, the random walk based algorithm is utilized to extract co-occurrence relations from the new graph. Since `struc2vec` shares the same mapping and reconstructor functions as Deepwalk, we only detail the extractor of `struc2vec`. It includes the structural similarity measure, the built new graph, and the biased random walk to extract the co-occurrence relations based on the new graph.

Measuring Structural Role Similarity

Intuitively, the degree of nodes can indicate their structural role similarity. In other words, two nodes with similar degree can be considered as structurally similar. Furthermore, if their neighbors also have similar degree, these nodes can be even more similar. Based on this intuition, a hierarchical structural similarity measure is proposed in (Ribeiro et al., 2017). We use $R_k(v)$ to denote the set of nodes that are k -hop away from the node v . We order the nodes in $R_k(v)$ according to their degree to the degree sequence $s(R_k(v))$. Then, the structural distance $g_k(v_1, v_2)$ between two nodes v_1 and v_2 considering their k -hop neighborhoods can be recursively defined as follows:

$$g_k(v_1, v_2) = g_{k-1}(v_1, v_2) + \text{dis}(s(R_k(v_1)), s(R_k(v_2))),$$

where $\text{dis}(s(R_k(v_1)), s(R_k(v_2))) \geq 0$ measures the distance between the ordered degree sequences of v_1 and v_2 . In other words, it indicates the degree similarity of k -hop neighbors of v_1 and v_2 . Note that $g_{-1}(\cdot, \cdot)$ is initialized with 0. Both $\text{dis}(\cdot, \cdot)$ and $g_k(\cdot, \cdot)$ are distance measures. Therefore, the larger they are, more dissimilar the two compared inputs are. The sequences $s(R_k(v_1))$ and $s(R_k(v_2))$ can be of different lengths and their elements are arbitrary integers. Thus, Dynamic Time Warping (DTW) (Sailer, 1978; Salvador and Chan, 2007) is adopted as the distance function $\text{dis}(\cdot, \cdot)$ since it can deal with sequences with different sizes. The DTW algorithm finds the optimal alignment between two sequences such that the sum of the distance between the aligned elements is minimized. The distance between two elements a and b is measured as:

$$l(a, b) = \frac{\max(a, b)}{\min(a, b)} - 1.$$

Note that this distance depends on the ratio between the maximum and minimum of the two elements; thus, it can regard $l(1, 2)$ much different from $l(100, 101)$, which is desired when measuring difference between degrees.

Constructing a Graph Based on Structural Similarity

After obtaining the pairwise structural distance, we can construct a multi-layer weighted graph that encodes the structural similarity between the nodes. Specifically, with k^* as the diameter of the original graph \mathcal{G} , we can build a k^* layer graph where the k -th layer is built upon the weights defined as follows:

$$w_k(u, v) = \exp(-g_k(u, v)).$$

Here, $w_k(u, v)$ denotes the weight of the edge between nodes u and v in the k -th layer of the graph. The connection between nodes u and v is stronger when the distance $g_k(u, v)$ is smaller. Next, we connect different layers in the graph with directed edges. In particular, every node v in the layer k is connected to its corresponding node in the layers $k - 1$ and $k + 1$. We denote the node v in the k -th layer as $v^{(k)}$ and the edge weights between layers are defined as follows

$$\begin{aligned} w(v^{(k)}, v^{(k+1)}) &= \log(\Gamma_k(v) + e), k = 0, \dots, k^* - 1, \\ w(v^{(k)}, v^{(k-1)}) &= 1, k = 1, \dots, k^*, \end{aligned}$$

where

$$\Gamma_k(v) = \sum_{v_j \in \mathcal{V}} \mathbb{1}(w_k(v, v_j) > \bar{w}_k)$$

with $\bar{w}_k = \sum_{(u,v) \in \mathcal{E}_k} w_k(u, v) / \binom{N}{2}$ denoting the average edge weight of the complete graph (\mathcal{E}_k is its set of edges) in the layer k . Thus, $\Gamma_k(v)$ measures the sim-

ilarity of node v to other nodes in the layer k . This design ensures that a node has a strong connection to the next layer if it is very similar to other nodes in the current layer. As a consequence, it is likely to guide the random walk to the next layer to acquire more information.

Biased Random Walks on the Built Graph

A biased random walk algorithm is proposed to generate a set of random walks, which are used to generate co-occurrence tuples to be reconstructed. Assume that the random walk is now at the node u in the layer k , for the next step, the random walk stays at the same layer with the probability q and jumps to another layer with the probability $1 - q$, where q is a hyper-parameter.

If the random walk stays at the same layer, the probability of stepping from the current node u to another node v is computed as follows

$$p_k(v|u) = \frac{\exp(-g_k(v, u))}{Z_k(u)},$$

where $Z_k(u)$ is a normalization factor for the node u in the layer k , which is defined as follows:

$$Z_k(u) = \sum_{(v,u) \in \mathcal{E}_k} \exp(-g_k(v, u)).$$

If the walk decides to walk to another layer, the probabilities to the layer $k + 1$ and to the layer $k - 1$ are calculated as follows:

$$\begin{aligned} p_k(u^{(k)}, u^{(k+1)}) &= \frac{w(u^{(k)}, u^{(k+1)})}{w(u^{(k)}, u^{(k+1)}) + w(u^{(k)}, u^{(k-1)})} \\ p_k(u^{(k)}, u^{(k-1)}) &= 1 - p_k(u^{(k)}, u^{(k+1)}) \end{aligned}$$

We can use this biased random walk to generate the set of random walks where we can extract the co-occurrence relations between nodes. Note that the co-occurrence relations are only extracted between different nodes, but not between the same node from different layers. In other words, the co-occurrence relations are only generated when the random walk takes steps with the same layer. These co-occurrence relations can serve as the information to be reconstructed from the embedding domain as DeepWalk.

4.2.3 Preserving Node Status

Global status of nodes, such as their centrality scores introduced in Section 2.3.3, is one type of important information in graphs. In (Ma et al., 2017), a graph embedding method is proposed to preserve node co-occurrence information and node global status jointly. The method mainly consists of two components: 1)

a component to preserve the co-occurrence information; and 2) a component to keep the global status. The component to preserve the co-occurrence information is the same as Deepwalk that is introduced in Section 4.2.1. Hence, in this section, we focus on the component to preserve the global status information. Instead of preserving global status scores for nodes in the graph, the proposed method aims to preserve their global status ranking. Hence, the extractor calculates the global status scores and then ranks the nodes according to their scores. The reconstructor is utilized to restore the ranking information. Next, we detail the extractor and the reconstructor.

Extractor

The extractor first calculates the global status scores and then obtains the global rank of the nodes. Any of the centrality measurements introduced in Section 2.3.3 can be utilized to calculate the global status scores. After obtaining the global status scores, the nodes can be rearranged in descending order according to the scores. We denote the rearranged nodes as $(v_{(1)}, \dots, v_{(N)})$ where the subscript indicate the rank of the node.

Reconstructor

The reconstructor is to recover the ranking information extracted by the extractor from the node embeddings. To reconstruct the global ranking, the reconstructor in (Ma et al., 2017) aims to preserve relative ranking of all pairs of nodes in $(v_{(1)}, \dots, v_{(N)})$. Assume that the order between a pair of nodes is independent of other pairs in $(v_{(1)}, \dots, v_{(N)})$, then the probability of the global ranking preserved can be modeled by using the node embedding as:

$$p_{global} = \prod_{1 \leq i < j \leq N} p(v_{(i)}, v_{(j)}),$$

where $p(v_{(i)}, v_{(j)})$ is the probability that node $v_{(i)}$ is ranked before $v_{(j)}$ based on their node embeddings. In detail, it is modeled as:

$$p(v_{(i)}, v_{(j)}) = \sigma(\mathbf{w}^T(\mathbf{u}_{(i)} - \mathbf{u}_{(j)})),$$

where $\mathbf{u}_{(i)}$ and $\mathbf{u}_{(j)}$ are the node embeddings for nodes $v_{(i)}$ and $v_{(j)}$ respectively (or outputs of the mapping function for $v_{(i)}$ and $v_{(j)}$), and \mathbf{w} is a vector of parameters to be learned. To preserve the order information, we expect that any ordered pair $(v_{(i)}, v_{(j)})$ should have a high probability to be constructed from the embedding. This can be achieved by minimizing the following objective function:

$$\mathcal{L}_{global} = -\log p_{global}.$$

Note that this objective \mathcal{L}_{global} can be combined with the objective to preserve the co-occurrence information such that the learned embeddings can preserve both the co-occurrence information and the global status.

4.2.4 Preserving Community Structure

Community structure is one of the most prominent features in graphs (Newman, 2006) that has motivated the development of embedding methods to preserve such critical information (Wang et al., 2017c; Li et al., 2018d). A matrix factorization based method is proposed to preserve both node-oriented structure, such as connections and co-occurrence, and community structure (Wang et al., 2017c). Next, we first use the general framework to describe its component to preserve node-oriented structure information, then introduce the component to preserve the community structure information with modularity maximization and finally discuss its overall objective.

Preserving Node-oriented Structure

Two types of node-oriented structure information are preserved (Wang et al., 2017c) – one is pairwise connectivity information, and the other is the similarity between the neighborhoods of nodes. Both types of information can be extracted from the given graph and represented in the form of matrices.

Extractor

The pairwise connection information can be extracted from the graph and be represented as the adjacency matrix \mathbf{A} . The goal of the reconstructor is to reconstruct the pairwise connection information (or the adjacency matrix) of the graph. The neighborhood similarity measures how similar the neighborhoods of two nodes are. For nodes v_i and v_j , their pairwise neighborhood similarity is computed as follows:

$$s_{i,j} = \frac{\mathbf{A}_i \mathbf{A}_j^\top}{\|\mathbf{A}_i\| \|\mathbf{A}_j\|},$$

where \mathbf{A}_i is the i -th row of the adjacency matrix, which denotes the neighborhood information of the node v_i . $s_{i,j}$ is larger when nodes v_i and v_j share more common neighbors and it is 0 if v_i and v_j do not share any neighbors. Intuitively if v_i and v_j share many common neighbors, i.e., $s_{i,j}$ is large, they are likely to co-occur in the random walks described in DeepWalk. Hence, this information has an implicit connection with the co-occurrence. These pairwise neighborhood similarity relations can be summarized in a matrix \mathbf{S} , where the i, j -th element is $s_{i,j}$. In summary, the extracted information can be denoted by

two matrices \mathbf{A} and \mathbf{S} .

Reconstructor and Objective

The reconstructor aims to recover these two types of extracted information in the form of \mathbf{A} and \mathbf{S} . To reconstruct them simultaneously, it first linearly combines them as follows:

$$\mathbf{P} = \mathbf{A} + \eta \cdot \mathbf{S},$$

where $\eta > 0$ controls the importance of the neighborhood similarity. Then, the matrix \mathbf{P} is reconstructed from the embedding domain as $\mathbf{W}_{con} \mathbf{W}_{cen}^T$, where \mathbf{W}_{con} and \mathbf{W}_{cen} are the parameters of two mapping functions f_{con} and f_{cen} . They have the same design as DeepWalk. The objective can be formulated as follows:

$$\mathcal{L}(\mathbf{W}_{con}, \mathbf{W}_{cen}) = \|\mathbf{P} - \mathbf{W}_{con} \mathbf{W}_{cen}^T\|_F^2,$$

where $\|\cdot\|_F$ denotes the Frobenius norm of a matrix.

Preserving the Community Structure

In a graph, a community consists of a set of nodes, which are densely connected. There often exist multiple communities in a graph. The task of community detection is to assign nodes in a graph into different communities. One popular community detection method is based on modularity maximization (Newman, 2006). Specifically, assuming that we are given a graph with 2 communities with known node-community assignment, the modularity can be defined as:

$$Q = \frac{1}{2 \cdot \text{vol}(\mathcal{G})} \sum_{ij} \left(\mathbf{A}_{i,j} - \frac{d(v_i)d(v_j)}{\text{vol}(\mathcal{G})} \right) h_i h_j,$$

where $d(v_i)$ is the degree of node v_i , $h_i = 1$ if node v_i belongs to the first community, otherwise, $h_i = -1$ and $\text{vol}(\mathcal{G}) = \sum_{v_i \in \mathcal{V}} d(v_i)$. In fact, $\frac{d(v_i)d(v_j)}{\text{vol}(\mathcal{G})}$ approximates the expected number of edges between nodes v_i and v_j in a randomly generated graph. The randomly generated graph has the same set of nodes, the same node degree and the same number of edges as \mathcal{G} ; however, its edges are randomly placed between nodes. Hence, the modularity Q is defined based on the difference between the fraction of observed edges that fall within communities in the original graph and the corresponding expected fraction in the randomly generated graph. A positive modularity Q suggests the possible presence of community structure and often a larger modularity Q indicates better community structures discovered (Newman, 2006). Hence, to detect good

communities, we can maximize the modularity Q by finding the proper community assignments. Furthermore, the modularity Q can be written in a matrix form as :

$$Q = \frac{1}{2 \cdot \text{vol}(\mathcal{G})} \mathbf{h}^T \mathbf{B} \mathbf{h},$$

where $\mathbf{h} \in \{-1, 1\}^N$ is the community assignment vector with the i -th element $\mathbf{h}[i] = h_i$ and $\mathbf{B} \in \mathbb{R}^{N \times N}$ is defined as :

$$\mathbf{B}_{i,j} = \mathbf{A}_{i,j} - \frac{d(v_i)d(v_j)}{\text{vol}(\mathcal{G})}.$$

The definition of the modularity can be extended to $m > 2$ communities. In detail, the community assignment vector \mathbf{h} can be generalized as a matrix $\mathbf{H} \in \{0, 1\}^{N \times m}$ where each column of \mathbf{H} represents a community. The i -th row of the matrix \mathbf{H} is a one-hot vector indicating the community of node v_i , where only one element of this row is 1 and others are 0. Therefore, we have $\text{tr}(\mathbf{H}^T \mathbf{H}) = N$, where $\text{tr}(\mathbf{X})$ denotes the trace of a matrix \mathbf{X} . After discarding some constants, the modularity for a graph with m communities can be defined as: $Q = \text{tr}(\mathbf{H}^T \mathbf{B} \mathbf{H})$. The assignment matrix \mathbf{H} can be learned by maximizing the modularity Q as:

$$\max_{\mathbf{H}} Q = \text{tr}(\mathbf{H}^T \mathbf{B} \mathbf{H}), \quad \text{s.t. } \text{tr}(\mathbf{H}^T \mathbf{H}) = N.$$

Note that \mathbf{H} is a discrete matrix which is often relaxed to be a continuous matrix during the optimization process.

The Overall Objective

To jointly preserve the node-oriented structure information and the community structure information, another matrix \mathbf{C} is introduced to reconstruct the indicator matrix \mathbf{H} together with \mathbf{W}_{cen} . As a result, the objective of the entire framework is as:

$$\min_{\mathbf{W}_{con}, \mathbf{W}_{cen}, \mathbf{H}, \mathbf{C}} \|\mathbf{P} - \mathbf{W}_{con} \mathbf{W}_{cen}^T\|_F^2 + \alpha \|\mathbf{H} - \mathbf{W}_{cen} \mathbf{C}^T\|_F^2 - \beta \cdot \text{tr}(\mathbf{H}^T \mathbf{B} \mathbf{H}),$$

$$\text{s.t. } \mathbf{W}_{con} \geq 0, \mathbf{W}_{cen} \geq 0, \mathbf{C} \geq 0, \text{tr}(\mathbf{H}^T \mathbf{H}) = N.$$

where the term $\|\mathbf{H} - \mathbf{W}_{cen} \mathbf{C}^T\|_F^2$ connects the community structure information with the node representations, the non-negative constraints are added as non-negative matrix factorization is adopted by (Wang et al., 2017c) and the hyperparameters α and β control the balance among three terms.

4.3 Graph Embedding on Complex Graphs

In previous sections, we have discussed graph embedding algorithms for simple graphs. However, as shown in Section 2.6, real-world graphs present much more complicated patterns, resulting in numerous types of complex graphs. In this section, we introduce embedding methods for these complex graphs.

4.3.1 Heterogeneous Graph Embedding

In heterogeneous graphs, there are different types of nodes. In (Chang et al., 2015), a framework HNE was proposed to project different types of nodes in the heterogeneous graph into a common embedding space. To achieve this goal, a distinct mapping function is adopted for each type. Nodes are assumed to be associated with node features that can have different forms (e.g., images or texts) and dimensions. Thus, different deep models are employed for each type of nodes to map the corresponding features into the common embedding space. For example, if the associated feature is in the form of images, CNNs are adopted as the mapping function. HNE aims to preserve the pairwise connections between nodes. Thus, the extractor in HNE extracts node pairs with edges as the information to be reconstructed, which can be naturally denoted by the adjacency matrix \mathbf{A} . Hence, the reconstructor is to recover the adjacency matrix \mathbf{A} from the node embeddings. Specifically, given a pair of nodes (v_i, v_j) and their embeddings $\mathbf{u}_i, \mathbf{u}_j$ learned by the mapping functions, the probability of the reconstructed adjacency element $\tilde{\mathbf{A}}_{i,j} = 1$ is computed as follows:

$$p(\tilde{\mathbf{A}}_{i,j} = 1) = \sigma(\mathbf{u}_i^\top \mathbf{u}_j),$$

where σ is the sigmoid function. Correspondingly,

$$p(\tilde{\mathbf{A}}_{i,j} = 0) = 1 - \sigma(\mathbf{u}_i^\top \mathbf{u}_j).$$

The goal is to maximize the probability such that the reconstructed adjacency matrix $\tilde{\mathbf{A}}$ is close to the original adjacency matrix \mathbf{A} . Therefore, the objective is modeled by the cross-entropy as follows:

$$-\sum_{i,j=1}^N (\mathbf{A}_{i,j} \log p(\tilde{\mathbf{A}}_{i,j} = 1) + (1 - \mathbf{A}_{i,j}) \log p(\tilde{\mathbf{A}}_{i,j} = 0)). \quad (4.10)$$

The mapping functions can be learned by minimizing the objective in Eq. (4.10) where the embeddings can be obtained. In heterogeneous graphs, different types of nodes and edges carry different semantic meanings. Thus, for heterogeneous network embedding, we should not only care about the structural correlations between nodes but also their semantic correlations. `metapath2vec` (Dong

et al., 2017) is proposed to capture both correlations between nodes. Next, we detail the `metapath2vec` (Dong et al., 2017) algorithm including its extractor, reconstructor and objective. Note that the mapping function in `metapath2vec` is the same as `DeepWalk`.

Meta-path based Information Extractor

To capture both the structural and semantic correlations, meta-path based random walks are introduced to extract the co-occurrence information. Specifically, meta-paths are employed to constrain the decision of random walks. Next, we first introduce the concept of meta-paths and then describe how to design the meta-path based random walk.

Definition 4.5 (Meta-path Schema) Given a heterogeneous graph \mathcal{G} as defined in Definition 2.35, a meta-path schema ψ is a meta-template in \mathcal{G} denoted as $A_1 \xrightarrow{R_1} A_2 \xrightarrow{R_2} \dots \xrightarrow{R_l} A_{l+1}$, where $A_i \in \mathcal{T}_n$ and $R_i \in \mathcal{T}_e$ denote certain types of nodes and edges, respectively. The meta path schema defines a composite relation between nodes from type A_1 to type A_{l+1} where the relation can be denoted as $R = R_1 \circ R_2 \circ \dots \circ R_{l-1} \circ R_l$. An instance of a meta-path schema ψ is a meta-path, where each node and edge in the path follows the corresponding types in the schema.

Meta-path schema can be used to guide the random walks. A meta-path-based random walk is a randomly generated instance of a given meta-path schema ψ . The formal definition of a meta-path based random walk is given below:

Definition 4.6 Given a meta-path schema $\psi : A_1 \xrightarrow{R_1} A_2 \xrightarrow{R_2} \dots \xrightarrow{R_l} A_{l+1}$, the transition probability of a random walk guided by ψ can be computed as:

$$p(v^{(t+1)}|v^{(t)}, \psi) = \begin{cases} \frac{1}{|\mathcal{N}_{t+1}^{R_t}(v^{(t)})|}, & \text{if } v^{(t+1)} \in \mathcal{N}_{t+1}^{R_t}(v^{(t)}), \\ 0, & \text{otherwise,} \end{cases}$$

where $v^{(t)}$ is a node of type A_t , corresponding to the position of A_t in the meta-path schema. $\mathcal{N}_{t+1}^{R_t}(v^{(t)})$ denotes the set of neighbors of $v^{(t)}$ which have the node type A_{t+1} and connect to $v^{(t)}$ through edge type R_t . It can be formally defined as:

$$\mathcal{N}_{t+1}^{R_t}(v^{(t)}) = \{v_j \mid v_j \in \mathcal{N}(v^{(t)}) \text{ and } \phi_n(v_j) = A_{t+1} \text{ and } \phi_e(v^{(t)}, v_j) = R_t\}.$$

where $\phi_n(v_j)$ is a function to retrieve the type of node v_j and $\phi_e(v^{(t)}, v_j)$ is a function to retrieve the type of edge $(v^{(t)}, v_j)$ as introduced in Definition 2.35.

Then, we can generate random walks under the guidance of various meta-path schemas from which co-occurrence pairs can be extracted in the same way as that in Section 4.2.1. Likewise, we denote tuples extracted from the random walks in the form of (v_{con}, v_{cen}) as \mathcal{I} .

Reconstructor

There are two types of reconstructors proposed in (Dong et al., 2017). The first one is the same as that for DeepWalk (or Eq. (4.2)) in Section 4.2.1. The other reconstructor is to define a multinomial distribution for each type of nodes instead of a single distribution over all nodes as Eq. (4.2). For a node v_j with type nt , the probability of observing v_j given v_i can be computed as follows:

$$p(v_j|v_i) = \frac{\exp(f_{con}(v_j)^\top f_{cen}(v_i))}{\sum_{v \in \mathcal{V}_{nt}} \exp(f_{con}(v)^\top f_{cen}(v_i))},$$

where \mathcal{V}_{nt} is a set consisting of all nodes with type $nt \in \mathcal{T}_n$. We can adopt either of the two reconstructors and then construct the objective in the same way as that of DeepWalk in Section 4.2.1.

4.3.2 Bipartite Graph Embedding

As defined in Definition 2.36, in bipartite graphs, there are two disjoint sets of nodes \mathcal{V}_1 and \mathcal{V}_2 , and no edges are existing within these two sets. For convenience, we use \mathcal{U} and \mathcal{V} to denote these two disjoint sets. In (Gao et al., 2018b), a bipartite graph embedding framework BiNE is proposed to capture the relations between the two sets and the relations within each set. Especially, two types of information are extracted: 1) the set of edges \mathcal{E} , which connect the nodes from the two sets, and 2) the co-occurrence information of nodes within each set. The same mapping function as DeepWalk is adopted to map the nodes in the two sets to the node embeddings. We use \mathbf{u}_i and \mathbf{v}_i to denote the embeddings for nodes $u_i \in \mathcal{U}$ and $v_i \in \mathcal{V}$, respectively. Next, we introduce the information extractor, reconstructor and the objective for BiNE.

Information Extractor

Two types of information are extracted from the bipartite graph. One is the edges between the nodes from the two node sets, denoted as \mathcal{E} . Each edge $e \in \mathcal{E}$ can be represented as $(u_{(e)}, v_{(e)})$ with $u_{(e)} \in \mathcal{U}$ and $v_{(e)} \in \mathcal{V}$. The other is the co-occurrence information within each node set. To extract the co-occurrence information in each node set, two homogeneous graphs with \mathcal{U}

and \mathcal{V} as node sets are induced from the bipartite graph, respectively. Specifically, if two nodes are 2-hop neighbors in the original graph, they are connected in the induced graphs. We use $\mathcal{G}_{\mathcal{U}}$ and $\mathcal{G}_{\mathcal{V}}$ to denote the graphs induced for node sets \mathcal{V} and \mathcal{U} , respectively. Then, the co-occurrence information can be extracted from the two graphs in the same way as DeepWalk. We denote the extracted co-occurrence information as $\mathcal{I}_{\mathcal{U}}$ and $\mathcal{I}_{\mathcal{V}}$, respectively. Therefore, the information to be reconstructed includes the set of edges \mathcal{E} and the co-occurrence information for \mathcal{U} and \mathcal{V} .

Reconstructor and Objective

The reconstructor to recover the co-occurrence information in \mathcal{U} and \mathcal{V} from the embeddings is the same as that for DeepWalk. We denote the two objectives for re-constructing $\mathcal{I}_{\mathcal{U}}$ and $\mathcal{I}_{\mathcal{V}}$ as $\mathcal{L}_{\mathcal{U}}$ and $\mathcal{L}_{\mathcal{V}}$, respectively. To recover the set of edges \mathcal{E} , we model the probability of observing the edges based on the embeddings. Specifically, given a node pair (u_i, v_j) with $u_i \in \mathcal{U}$ and $v_j \in \mathcal{V}$, we define the probability that there is an edge between the two nodes in the original bipartite graph as:

$$p(u_i, v_j) = \sigma(\mathbf{u}_i^\top \mathbf{v}_j),$$

where σ is the sigmoid function. The goal is to learn the embeddings such that the probability for the node pairs of edges in \mathcal{E} can be maximized. Thus, the objective is defined as

$$\mathcal{L}_{\mathcal{E}} = - \sum_{(u_i, v_j) \in \mathcal{E}} \log p(u_i, v_j).$$

The final objective of BiNE is as follows:

$$\mathcal{L} = \mathcal{L}_{\mathcal{E}} + \eta_1 \mathcal{L}_{\mathcal{U}} + \eta_2 \mathcal{L}_{\mathcal{V}},$$

where η_1 and η_2 are the hyperparameters to balance the contributions for different types of information.

4.3.3 Multi-dimensional Graph Embedding

In a multi-dimensional graph, all dimensions share the same set of nodes, while having their own graph structures. For each node, we aim to learn (1) a general node representation, which captures the information from all the dimensions and (2) a dimension specific representation for each dimension, which focuses more on the corresponding dimension (Ma et al., 2018d). The general representations can be utilized to perform general tasks such as node classification which requires the node information from all dimensions. Meanwhile,

the dimension-specific representation can be utilized to perform dimension-specific tasks such as link prediction for a certain dimension. Intuitively, for each node, the general representation and the dimension-specific representation are not independent. Therefore, it is important to model their dependence. To achieve this goal, for each dimension d , we model the dimension-specific representation $\mathbf{u}_{d,i}$ for a given node v_i as

$$\mathbf{u}_{d,i} = \mathbf{u}_i + \mathbf{r}_{d,i}, \quad (4.11)$$

where \mathbf{u}_i is the general representation and $\mathbf{r}_{d,i}$ is the representation capturing information only in the dimension d without considering the dependence. To learn these representations, we aim to reconstruct the co-occurrence relations in different dimensions. Specifically, we optimize mapping functions for \mathbf{u}_i and $\mathbf{r}_{d,i}$ by reconstructing the co-occurrence relations extracted from different dimensions. Next, we introduce the mapping functions, the extractor, the reconstructor and the objective for the multi-dimensional graph embedding.

The mapping functions

The mapping function for the general representation is denoted as $f()$, while the mapping function for a specific dimension d is $f_d()$. Note that all the mapping functions are similar to that in DeepWalk. They are implemented as looking-up tables as follows

$$\begin{aligned} \mathbf{u}_i &= f(v_i) = \mathbf{e}_i^\top \mathbf{W}, \\ \mathbf{r}_{d,i} &= f_d(v_i) = \mathbf{e}_i^\top \mathbf{W}_d, d = 1 \dots, D, \end{aligned}$$

where D is the number of dimensions in the multi-dimensional graph.

Information Extractor

We extract co-occurrence relations for each dimension d as \mathcal{I}_d using the co-occurrence extractor introduced in Section 4.2.1. The co-occurrence information of all dimensions is the union of that for each dimension as follows:

$$\mathcal{I} = \cup_{d=1}^D \mathcal{I}_d.$$

The Reconstructor and Objective

We aim to learn the mapping functions such that the probability of the co-occurrence \mathcal{I} can be well reconstructed. The reconstructor is similar to that in DeepWalk. The only difference is that the reconstructor is now applied to the extracted relations from different dimensions. Correspondingly, the objective

can be stated as follows:

$$\min_{\mathbf{w}, \mathbf{W}_1, \dots, \mathbf{W}_D} - \sum_{d=1}^D \sum_{(v_{con}, v_{cen}) \in \mathcal{I}_d} \#(v_{con}, v_{cen}) \cdot \log p(v_{con}|v_{cen}), \quad (4.12)$$

where $\mathbf{W}, \mathbf{W}_1, \dots, \mathbf{W}_D$ are the parameters of the mapping functions to be learned. Note that in (Ma et al., 2018d), for a given node, the same representation is used for both the center and the context representations.

4.3.4 Signed Graph Embedding

In signed graphs, there are both positive and negative edges between nodes, as introduced in Definition 2.38. Structural balance theory is one of the most important social theories for signed graphs. A signed graph embedding algorithm SiNE based on structural balance theory is proposed (Wang et al., 2017b). As suggested by balance theory (Cygan et al., 2012), nodes should be closer to their “friends” (or nodes with positive edges) than their “foes” (or nodes with negative edges). For example, in Figure 4.4, v_j and v_k can be regarded as the “friend” and “foe” of v_i , respectively. SiNE aims to map “friends” closer than “foes” in the embedding domain, i.e., mapping v_j closer than v_k to v_i . Hence, the information to preserve by SiNE is the relative relations between “friends” and “foes”. Note that the mapping function in SiNE is the same as that in DeepWalk. Next, we first describe the information extractor and then introduce the reconstructor.

Information Extractor

The information to preserve can be represented as a triplet (v_i, v_j, v_k) as shown in Figure 4.4, where nodes v_i and v_j are connected by a positive edge while nodes v_i and v_k are connected by a negative edge. Let \mathcal{I}_1 denote a set of these triplets in a signed graph, which can be formally defined as:

$$\mathcal{I}_1 = \left\{ (v_i, v_j, v_k) \mid \mathbf{A}_{i,j} = 1, \mathbf{A}_{i,k} = -1, v_i, v_j, v_k \in \mathcal{V} \right\},$$

where \mathbf{A} is the adjacency matrix of the signed graph as defined in Definition 2.38. In the triplet (v_i, v_j, v_k) , the node v_j is supposed to be more similar to v_i than the node v_k according to balance theory. For a given node v , we define its 2-hop subgraph as the subgraph formed by the node v , nodes that are within 2-hops of v and all the edges between these nodes. In fact, the extracted information \mathcal{I}_1 does not contain any information for a node v whose 2-hop subgraph has only positive or negative edges. In this case, all triplets involving v contain edges with the same sign as illustrated in Figure 4.5. Thus, we need

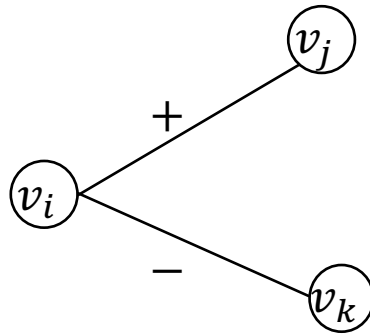
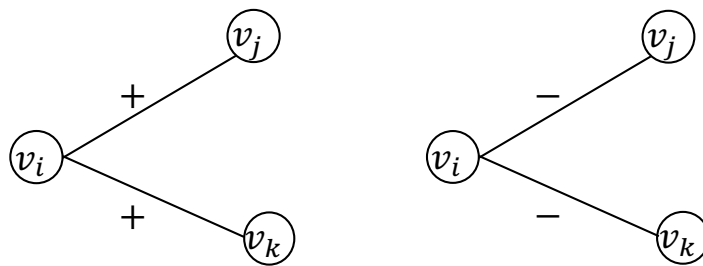

Figure 4.4 A triplet consists of a positive edge and a negative edge



(a) A triplet with only positive edges

(b) A triplet with only negative edges

Figure 4.5 Triplets with edges of the same sign

to specify the information to preserve for these nodes in order to learn their representations.

It is evident that the cost of forming negative edges is higher than that of forming positive edges (Tang et al., 2014b). Therefore, in social networks, many nodes have only positive edges in their 2-hop subgraphs while very few have only negative edges in their 2-hop subgraphs. Hence, we only consider to handle nodes whose 2-hop subgraphs have only positive edges, while a similar strategy can be applied to deal with the other type of nodes. To effectively capture the information for these nodes, we introduce a virtual node v_0 and then create negative edges between the virtual node v_0 and each of these nodes. In this way, such triplet (v_i, v_j, v_k) as shown in Figure 4.5a can be split into two triplets (v_i, v_j, v_0) and (v_i, v_k, v_0) as shown in Figure 4.6. Let \mathcal{I}_0 denote all these edges involving the virtual node v_0 . The information we extract can be denoted as $\mathcal{I} = \mathcal{I}_1 \cup \mathcal{I}_0$.

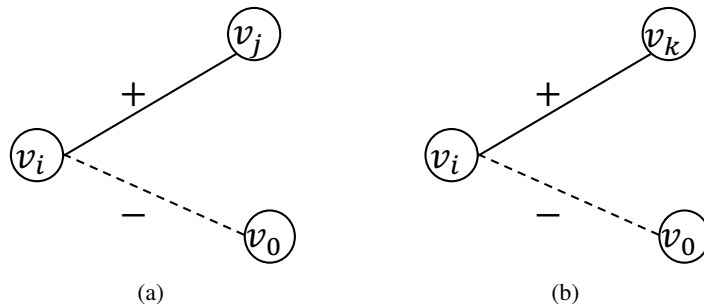

Figure 4.6 Expanding triplet in Figure 4.5a with a virtual node

Reconstructor

To reconstruct the information of a given triplet, we aim to infer the relative relations of the triplet based on the node embeddings. For a triplet (v_i, v_j, v_k) , the relative relation between v_i, v_j and v_k can be mathematically reconstructed using their embeddings as follows:

$$s(f(v_i), f(v_j)) - (s(f(v_i), f(v_k)) + \delta) \quad (4.13)$$

where $f()$ is the same mapping function as that in Eq.(4.1). The function $s(\cdot, \cdot)$ measures the similarity between two given node representations, which is modeled with feedforward neural networks. Eq. (4.13) larger than 0 suggests that v_i is more similar to v_j than v_k . The parameter δ is a threshold to regulate the difference between the two similarities. For example, a larger δ means that v_i and v_j should be much more similar with each other than v_i and v_k to make Eq. (4.13) larger than 0. For any triplet (v_i, v_j, v_k) in \mathcal{I} , we expect Eq.(4.13) to be larger than 0 such that the relative information can be preserved, i.e., v_i and v_j connected with a positive edge are more similar than v_i and v_k connected with a negative edge.

The Objective

To ensure that the information in \mathcal{I} can be preserved by node representations, we need to optimize the mapping function such that Eq.(4.13) can be larger than 0 for all triplets in \mathcal{I} . Hence, the objective function can be defined as

follows:

$$\begin{aligned} \min_{\mathbf{W}, \Theta} \frac{1}{|\mathcal{I}_0| + |\mathcal{I}_1|} [& \sum_{(v_i, v_j, v_k) \in \mathcal{I}_1} \max(0, s(f(v_i), f(v_k)) + \delta - s(f(v_i), f(v_j))) \\ & + \sum_{(v_i, v_j, v_0) \in \mathcal{I}_0} \max(0, s(f(v_i), f(v_0)) + \delta_0 - s(f(v_i), f(v_j))) \\ & + \alpha(R(\Theta) + \|\mathbf{W}\|_F^2)] \end{aligned}$$

where \mathbf{W} is the parameters of the mapping function, Θ denotes the parameters of $s(\cdot, \cdot)$ and $R(\Theta)$ is the regularizer on the parameters. Note that, we use different parameters δ and δ_0 for \mathcal{I}_1 and \mathcal{I}_0 to flexibly distinguish the triplets from the two sources.

4.3.5 Hypergraph Embedding

In a hypergraph, a hyperedge captures relations between a set of nodes, as introduced in Section 2.6.5. In (Tu et al., 2018), a method DHNE is proposed to learn node representations for hypergraphs by utilizing the relations encoded in hyperedges. Specifically, two types of information are extracted from hyperedges that are reconstructed by the embeddings. One is the proximity described directly by hyperedges. The other is the co-occurrence of nodes in hyperedges. Next, we introduce the extractor, the mapping function, the reconstructor and the objective of DHNE.

Information Extractor

Two types of information are extracted from the hypergraph. One is the hyperedges. The set of hyperedges denoted as \mathcal{E} directly describes the relations between nodes. The other type is the hyperedge co-occurrence information. For a pair of nodes v_i and v_j , the frequency they co-occur in hyperedges indicates how strong their relation is. The hyperedge co-occurrence between any pair of nodes can be extracted from the incidence matrix \mathbf{H} as follows:

$$\mathbf{A} = \mathbf{H}\mathbf{H}^\top - \mathbf{D}_v$$

where \mathbf{H} is the incidence matrix and \mathbf{D}_v is the diagonal node degree matrix as introduced in Definition 2.39. The i, j -th element $\mathbf{A}_{i,j}$ indicates the number of times that nodes v_i and v_j co-occur in hyperedges. For a node v_i , the i -th row of \mathbf{A} describes its co-occurrence information with all nodes in the graph (or the global information of node v_i). In summary, the extracted information includes the set of hyperedges \mathcal{E} and the global co-occurrence information \mathbf{A} .

The Mapping Function

The mapping function is modeled with multi-layer feed forward networks with the global co-occurrence information as the input. Specifically, for node v_i , the process can be stated as:

$$\mathbf{u}_i = f(\mathbf{A}_i; \Theta),$$

where f denotes the feedforward networks with Θ as its parameters.

Reconstructor and Objective

There are two reconstructors to recover the two types of extracted information, respectively. We first describe the reconstructor to recover the set of hyperedges \mathcal{E} and then introduce the reconstructor for the co-occurrence information \mathbf{A} . To recover the hyperedge information from the embeddings, we model the probability of a hyperedge existing between any given set of nodes $\{v_{(1)}, \dots, v_{(k)}\}$ and then aim to maximize the probability for those hyperedges in \mathcal{E} . For convenience, in (Tu et al., 2018), all hyperedges are assumed to have a set of k nodes. The probability that a hyperedge exists in a given set of nodes $\mathcal{V}^i = \{v_{(1)}^i, \dots, v_{(k)}^i\}$ is defined as:

$$p(1|\mathcal{V}^i) = \sigma(g([\mathbf{u}_{(1)}^i, \dots, \mathbf{u}_{(k)}^i]))$$

where $g()$ is a feedforward network that maps the concatenation of the node embeddings to a single scalar and $\sigma()$ is the sigmoid function that transforms the scalar to the probability. Let R^i denote the variable to indicate whether there is a hyperedge between the nodes in \mathcal{V}^i in the hypergraph where $R^i = 1$ denotes that there is an hyperedge while $R^i = 0$ means no hyperedge. Then the objective is modeled based on cross-entropy as:

$$\mathcal{L}_1 = - \sum_{\mathcal{V}^i \in \mathcal{E} \cup \mathcal{E}'} R^i \log p(1|\mathcal{V}^i) + (1 - R^i) \log(1 - p(1|\mathcal{V}^i)),$$

where \mathcal{E}' is a set of negative “hyperedges” that are randomly generated to serve as negative samples. Each of the negative “hyperedge” $\mathcal{V}^i \in \mathcal{E}'$ consists of a set of k randomly sampled nodes.

To recover the global co-occurrence information \mathbf{A}_i for node v_i , a feedforward network, which takes the embedding \mathbf{u}_i as input, is adopted as:

$$\tilde{\mathbf{A}}_i = f_{re}(\mathbf{u}_i; \Theta_{re}),$$

where $f_{re}()$ is the feedforward network to reconstruct the co-occurrence information with Θ_{re} as its parameters. The objective is then defined with least

square as:

$$\mathcal{L}_2 = \sum_{v_i \in \mathcal{V}} \|\mathbf{A}_i - \tilde{\mathbf{A}}_i\|_2^2.$$

The two objectives are then combined to form the objective for the entire network embedding framework as:

$$\mathcal{L} = \mathcal{L}_1 + \eta \mathcal{L}_2,$$

where η is a hyperparameter to balance the two objectives.

4.3.6 Dynamic Graph Embedding

In dynamic graphs, edges are associated with timestamps which indicate their emerging time as introduced in Section 2.6.6. It is vital to capture the temporal information when learning the node representations. In (Nguyen et al., 2018), temporal random walk is proposed to generate random walks that capture temporal information in the graph. The generated temporal random walks are then employed to extract the co-occurrence information to be reconstructed. Since its mapping function, reconstructor and objective are the same as those in DeepWalk, we mainly introduce the temporal random walk and the corresponding information extractor.

Information Extractor

To capture both the temporal and the graph structural information, the temporal random walk is introduced in (Nguyen et al., 2018). A valid temporal random walk consists of a sequence of nodes connected by edges with non-decreasing time stamps. To formally introduce temporal random walks, we first define the set of temporal neighbors for a node v_i at a given time t as:

Definition 4.7 (Temporal Neighbors) For a node $v_i \in \mathcal{V}$ in a dynamic graph \mathcal{G} , its temporal neighbors at time t are those nodes connected with v_i after time t . Formally, it can be expressed as follows:

$$\mathcal{N}_{(t)}(v_i) = \{v_j | (v_i, v_j) \in \mathcal{E} \text{ and } \phi_e((v_i, v_j)) \geq t\}$$

where $\phi_e((v_i, v_j))$ is the temporal mapping function. It maps a given edge to its associated time as defined in Definition 2.40.

The temporal random walks can then be stated as follows:

Definition 4.8 (Temporal Random Walks) Let $\mathcal{G} = \{\mathcal{V}, \mathcal{E}, \phi_e\}$ be a dynamic graph where ϕ_e is the temporal mapping function for edges. We consider a temporal random walk starting from a node $v^{(0)}$ with $(v^{(0)}, v^{(1)})$ as its first edge.

Assume that at the k -th step, it just proceeds from node $v^{(k-1)}$ to node $v^{(k)}$ and now we choose the next node from the temporal neighbors $\mathcal{N}_{(\phi_e((v^{(k-1)}, v^{(k)})))}(v^{(k)})$ of node $v^{(k)}$ with the following probability:

$$p(v^{(k+1)}|v^{(k)}) = \begin{cases} pre(v^{(k+1)}) & \text{if } v^{(k+1)} \in \mathcal{N}_{(\phi_e((v^{(k-1)}, v^{(k)})))}(v^{(k)}) \\ 0, & \text{otherwise,} \end{cases}$$

where $pre(v^{(k+1)})$ is defined below where nodes with smaller time gaps to the current time are chosen with higher probability:

$$pre(v^{(k+1)}) = \frac{\exp[\phi_e((v^{(k-1)}, v^{(k)})) - \phi_e((v^{(k)}, v^{(k+1)})]}{\sum_{v^{(j)} \in \mathcal{N}_{(\phi_e((v^{(k-1)}, v^{(k)})))}(v^{(k)})} \exp[\phi_e((v^{(k-1)}, v^{(k)})) - \phi_e((v^{(k)}, v^{(j)})]}.$$

A temporal random walk naturally terminates itself if there are no temporal neighbors to proceed. Hence, instead of generating random walks of fixed length as DeepWalk, we generate temporal random walks with length between the window size w for co-occurrence extraction and a pre-defined length T . These random walks are leveraged to generate the co-occurrence pairs, which are reconstructed with the same reconstructor as DeepWalk.

4.4 Conclusion

In this chapter, we introduce a general framework and a new perspective to understand graph embedding methods in a unified way. It mainly consists of four components including: 1) a mapping function, which maps nodes in a given graph to their embeddings in the embedding domain; 2) an information extractor, which extracts information from the graphs; 3) a reconstructor, which utilizes the node embeddings to reconstruct the extracted information; and 4) an objective, which often measures the difference between the extracted and reconstructed information. The embeddings can be learned by optimizing the objective. Following the general framework, we categorize graph embedding methods according to the information they aim to preserve including co-occurrence based, structural role based, global status based and community based methods and then detail representative algorithms in each group. Besides, under the general framework, we also introduce representative embedding methods for complex graphs, including heterogeneous graphs, bipartite graphs, multi-dimensional graphs, signed graphs, hypergraphs, and dynamic graphs.

4.5 Further Reading

There are embedding algorithms preserving the information beyond what we have discussed above. In (Rossi et al., 2018), motifs are extracted and are preserved in node representations. A network embedding algorithm to preserve asymmetric transitivity information is proposed in (Ou et al., 2016) for directed graphs. In (Bourigault et al., 2014), node representations are learned to model and predict information diffusion. For complex graphs, we only introduce the most representative algorithms. However, there are more algorithms for each type of complex graphs including heterogeneous graphs (Chen and Sun, 2017; Shi et al., 2018a; Chen et al., 2019b), bipartite graphs (Wang et al., 2019j; He et al., 2019), multi-dimensional graphs (Shi et al., 2018b), signed graphs (Yuan et al., 2017; Wang et al., 2017a), hypergraphs (Baytas et al., 2018) and dynamic graphs (Li et al., 2017a; Zhou et al., 2018b). Besides, there are quite a few surveys on graph embedding (Hamilton et al., 2017b; Goyal and Ferrara, 2018; Cai et al., 2018; Cui et al., 2018)

5

Graph Neural Networks

5.1 Introduction

Graph Neural Networks (GNNs) are a set of methods that aim to apply deep neural networks to graph-structured data. The classical deep neural networks cannot be easily generalized to graph-structured data as the graph structure is not a regular grid. The investigation of graph neural networks can date back to the early of the 21st century, when the first GNN model (Scarselli et al., 2005, 2008) was proposed for both node- and graph-focused tasks. When deep learning techniques gained enormous popularity in many areas, such as computer vision and natural language processing, researchers started to dedicate more efforts to this research area.

Graph neural networks can be viewed as a process of representation learning on graphs. For node-focused tasks, GNNs target on learning good features for each node such that node-focused tasks can be facilitated. For graph-focused tasks, they aim to learn representative features for the entire graph where learning node features is typically an intermediate step. The process of learning node features usually leverages both the input node features and the graph structure. More specifically, this process can be summarized as follows:

$$\mathbf{F}^{(\text{of})} = h(\mathbf{A}, \mathbf{F}^{(\text{if})}) \quad (5.1)$$

where $\mathbf{A} \in \mathbb{R}^{N \times N}$ denotes the adjacency matrix of the graph with N nodes (i.e., the graph structure) and $\mathbf{F}^{(\text{if})} \in \mathbb{R}^{N \times d_{\text{if}}}$ and $\mathbf{F}^{(\text{of})} \in \mathbb{R}^{N \times d_{\text{of}}}$ denote the input and output feature matrices where d_{if} and d_{of} are their dimensions, respectively. In this book, we generally refer to the process that takes node features and graph structure as input and outputs a new set of node features as *graph filtering* operation. The superscripts (or subscripts) “if” and “of” in Eq. (5.1) denote *the input of filtering* and *the output of filtering*, respectively. Correspondingly, the operator $h(\cdot, \cdot)$ is called as a *graph filter*. Figure 5.1 illustrates a typical

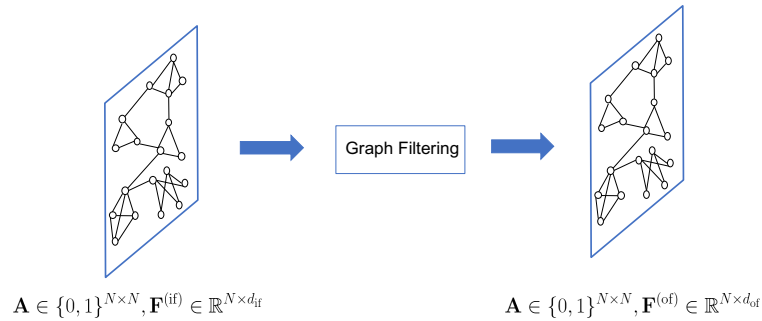

Figure 5.1 Graph filtering operation

graph filtering process where the filtering operation does not change the graph structure, but it only refines the node features.

For node-focused tasks, the graph filtering operation is sufficient, and multiple graph filtering operations are usually stacked consecutively to generate final node features. However, other operations are necessary for graph-focused tasks to generate the features for the entire graph from the node features. Similar to the classical CNNs, pooling operations are proposed to summarize node features to generate graph-level features. The classical CNNs are applied to data residing on regular grids. However, the graph structure is irregular, which calls for dedicated pooling operations in graph neural networks. Intuitively, pooling operations on graphs should utilize the graph structure information to guide the pooling process. In fact, pooling operations often take a graph as input and then produce a coarsened graph with fewer nodes. Thus, the key to pooling operations is to generate the graph structure (or the adjacency matrix) and the node features for the coarsened graph. In general, as shown in Figure 5.2, a graph pooling operation can be described as follows:

$$\mathbf{A}^{(op)}, \mathbf{F}^{(op)} = \text{pool}(\mathbf{A}^{(ip)}, \mathbf{F}^{(ip)}) \quad (5.2)$$

where $\mathbf{A}^{(ip)} \in \mathbb{R}^{N_{ip} \times N_{ip}}$, $\mathbf{F}^{(ip)} \in \mathbb{R}^{N_{ip} \times d_{ip}}$ and $\mathbf{A}^{(op)} \in \mathbb{R}^{N_{op} \times N_{op}}$, $\mathbf{F}^{(op)} \in \mathbb{R}^{N_{op} \times d_{op}}$ are the adjacency matrices and feature matrices before and after the pooling operation, respectively. Similarly the superscripts (or subscripts) “ip” and “op” are used to indicate *the input of pooling* and *the output of pooling*, respectively. Note that N_{op} denotes the number of nodes in the coarsened graph and $N_{op} < N_{ip}$.

The architecture of a typical graph neural network model consists of graph filtering and/or graph pooling operations. For node-focused tasks, GNNs only utilize graph filtering operations. They are often composed with multiple con-

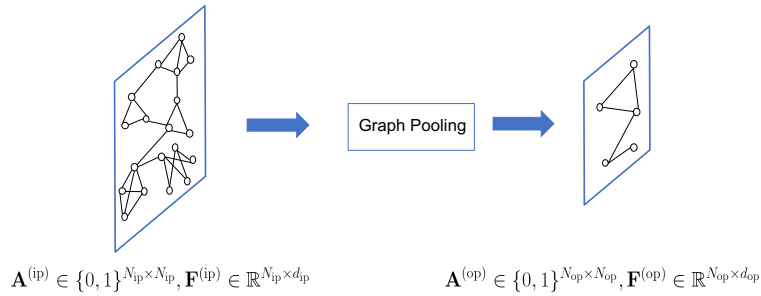

Figure 5.2 Graph pooling operation

secutive graph filtering layers where the output of the previous layer is the input for the following consecutive layer. For graph-focused tasks, GNNs require both the graph filtering and the graph pooling operations. Pooling layers usually separate the graph filtering layers into blocks. In this chapter, we first briefly introduce general architectures for GNNs and then provide the details of representative graph filtering and graph pooling operations.

5.2 The General GNN Frameworks

In this section, we introduce the general frameworks of GNNs for both node-focused and graph-focused tasks. We first introduce some notations that we use through the following sections. We denote a graph as $\mathcal{G} = \{\mathcal{V}, \mathcal{E}\}$. The adjacency matrix of the graph with N nodes is denoted as \mathbf{A} . The associated features are represented as $\mathbf{F} \in \mathbb{R}^{N \times d}$. Each row of \mathbf{F} corresponds to a node, and d is the dimension of the features.

5.2.1 A General Framework for Node-focused Tasks

A general framework for node-focused tasks can be regarded as a composition of graph filtering and non-linear activation layers. A GNN framework with L graph filtering layers and $L - 1$ activation layers (see Section 3.2.2 for representative activation functions) is shown in Figure 5.3, where $h_i()$ and $\alpha_i()$ denote the i -th graph filtering layer and activation layer, respectively. We use $\mathbf{F}^{(i)}$ to denote the output of the i -th graph filtering layer. Specifically, $\mathbf{F}^{(0)}$ is initialized to be the associated features \mathbf{F} . Furthermore, we use d_i to indicate the dimension of the output of the i -th graph filtering layer. Since the graph structure is unchanged, we have $\mathbf{F}^{(i)} \in \mathbb{R}^{N \times d_i}$. The i -th graph filtering layer can

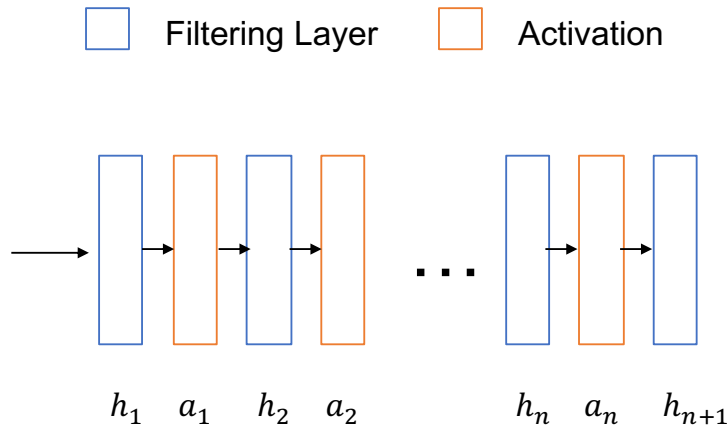

Figure 5.3 A general GNN architecture for node-focused tasks

be described as:

$$\mathbf{F}^{(i)} = h_i(\mathbf{A}, \alpha_{i-1}(\mathbf{F}^{(i-1)}))$$

where $\alpha_{i-1}()$ is the element-wise activation function following the $(i-1)$ -th graph filtering layer. Note that we abuse the notation a little bit to use α_0 to denote the identity function as we do not apply the activation on the input features. The final output $\mathbf{F}^{(L)}$ is leveraged as the input to some specific layers according to the downstream node-focused tasks.

5.2.2 A General Framework for Graph-focused Tasks

A general GNN framework for graph-focused tasks consists of three types of layers, i.e., the graph filtering layer, the activation layer, and the graph pooling layer. The graph filtering layer and the activation layer in the framework have similar functionalities as those in the node-focused framework. They are used to generate better node features. The graph pooling layer is utilized to summarize the node features and generate higher-level features that can capture the information of the entire graph. Typically, a graph pooling layer follows a series of graph filtering and activation layers. A coarsened graph with more abstract and higher-level node features is generated after the graph pooling layer. These layers can be organized into a *block* as shown in Figure 5.4 where h_i , α_i and p denote the i -th filtering layer, the i -th activation layer and the pooling layer in this block. The input of the block is the adjacency matrix $\mathbf{A}^{(\text{ib})}$ and the features $\mathbf{F}^{(\text{ib})}$ of a graph $\mathcal{G}_{ib} = \{\mathcal{V}_{ib}, \mathcal{E}_{ib}\}$ and the output is the newly

Filtering Layer
 Activation
 Pooling Layer

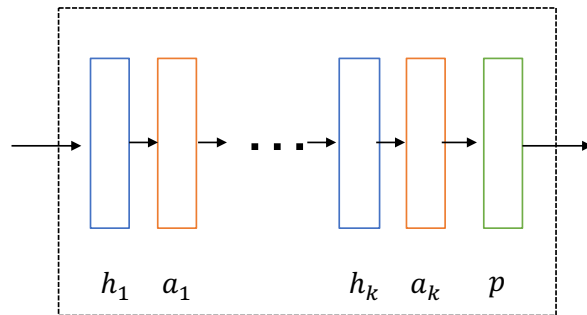

Figure 5.4 A block in GNNs for graph-focused tasks

generated adjacency matrix $\mathbf{A}^{(ob)}$ and the features $\mathbf{F}^{(ob)}$ for the coarsened graph $\mathcal{G}_{ob} = \{\mathcal{V}_{ob}, \mathcal{E}_{ob}\}$. The computation procedure of a block is formally stated as follows:

$$\begin{aligned}
 \mathbf{F}^{(i)} &= h_i(\mathbf{A}^{(ib)}, \alpha_{i-1}(\mathbf{F}^{(i-1)})) \quad \text{for } i = 1, \dots, k, \\
 \mathbf{A}^{(ob)}, \mathbf{F}^{(ob)} &= p(\mathbf{A}^{(ib)}, \mathbf{F}^{(k)}),
 \end{aligned} \tag{5.3}$$

where α_i is the activation function for $i \neq 0$ where α_0 is the identity function and $\mathbf{F}^{(0)} = \mathbf{F}^{ib}$. We can summarize the above computation process of a block as follows:

$$\mathbf{A}^{(ob)}, \mathbf{F}^{(ob)} = B(\mathbf{A}^{(ib)}, \mathbf{F}^{(ib)}).$$

The entire GNN framework can consist of one or more of these *blocks* as shown in Figure 5.5. The computation process of the GNN framework with L blocks can be formally defined as follows:

$$\mathbf{A}^{(j)}, \mathbf{F}^{(j)} = B^{(j)}(\mathbf{A}^{(j-1)}, \mathbf{F}^{(j-1)}) \quad \text{for } j = 1, \dots, L. \tag{5.4}$$

where $\mathbf{F}^{(0)} = \mathbf{F}$ and $\mathbf{A}^{(0)} = \mathbf{A}$ are the initial node features and the adjacency matrix of the original graph, respectively. Note that the output of one block is utilized as the input for the consecutively following block as shown in Eq. (5.4). When there is only one block (or $L = 1$), the GNN framework can be regarded as *flat* since it directly generates graph-level features from the original graph. The GNN framework with pooling layers can be viewed as a hierarchical process when $L > 1$, where the node features are gradually summarized to

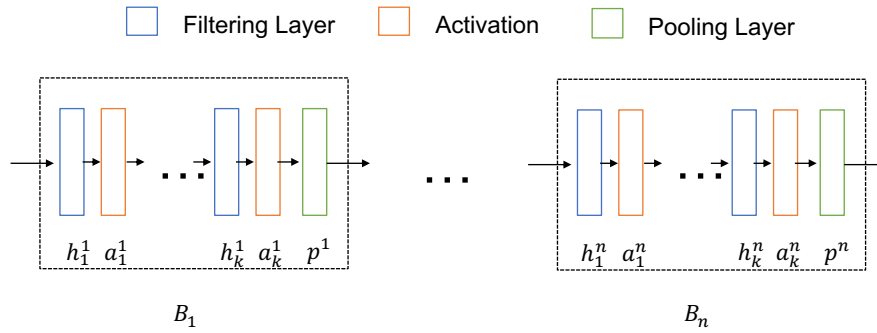

Figure 5.5 Architectures of GNNs for graph-focused tasks

form the graph features by subsequently generating more and more coarsened graphs.

5.3 Graph Filters

There are various perspectives to design graph filters, which can be roughly split into two categories: 1) spatial-based graph filters and 2) spectral-based graph filters. The spatial-based graph filters explicitly leverage the graph structure (i.e., the connections between the nodes) to perform the feature refining process in the graph domain. In contrast, the spectral-based graph filters utilize spectral graph theory to design the filtering operation in the spectral domain. These two categories of graph filters are closely related. Especially, some of the spectral-based graph filters can be regarded as spatial-based filters. In this section, we introduce spectral-based graph filters and explain how some of the spectral-based graph filters can be viewed from a spatial perspective. We then discuss more spatial-based graph filters.

5.3.1 Spectral-based Graph Filters

The spectral-based graph filters are designed in the spectral domain of graph signals. We first introduce the graph spectral filtering and then describe how it can be adopted to design spectral-based graph filters.

Graph Spectral Filtering

As shown in Figure 5.6, the idea of the graph spectral filtering is to modulate the frequencies of a graph signal such that some of its frequency components

are kept/amplified while others are removed/diminished. Hence, given a graph signal $\mathbf{f} \in \mathbb{R}^N$, we need first to apply Graph Fourier Transform (GFT) on it to obtain its graph Fourier coefficients, and then modulate these coefficients before reconstructing the signal in the spatial domain.

As introduced in Chapter 2, for a signal $\mathbf{f} \in \mathbb{R}^N$ defined on a graph \mathcal{G} , its Graph Fourier Transform is defined as follows:

$$\hat{\mathbf{f}} = \mathbf{U}^T \mathbf{f},$$

where \mathbf{U} consists of eigenvectors of the Laplacian matrix of \mathcal{G} and $\hat{\mathbf{f}}$ is the obtained graph Fourier coefficients for the signal \mathbf{f} . These graph Fourier coefficients describe how each graph Fourier component contributes to the graph signal \mathbf{f} . Specifically, the i -th element of $\hat{\mathbf{f}}$ corresponds to the i -th graph Fourier component \mathbf{u}_i with the frequency λ_i . Note that λ_i is the eigenvalue corresponding to \mathbf{u}_i . To modulate the frequencies of the signal \mathbf{f} , we filter the graph Fourier coefficients as follows:

$$\hat{\mathbf{f}}'[i] = \hat{\mathbf{f}}[i] \cdot \gamma(\lambda_i), \text{ for } i = 1, \dots, N.$$

where $\gamma(\lambda_i)$ is a function with the frequency λ_i as input which determines how the corresponding frequency component should be modulated. This process can be expressed in a matrix form as follows:

$$\hat{\mathbf{f}}' = \gamma(\mathbf{\Lambda}) \cdot \hat{\mathbf{f}} = \gamma(\mathbf{\Lambda}) \cdot \mathbf{U}^T \mathbf{f},$$

where $\mathbf{\Lambda}$ is a diagonal matrix consisting of the frequencies (eigenvalues of the Laplacian matrix) and $\gamma(\mathbf{\Lambda})$ is applying the function $\gamma()$ to each element in the diagonal of $\mathbf{\Lambda}$. Formally, $\mathbf{\Lambda}$ and $\gamma(\mathbf{\Lambda})$ can be represented as follows:

$$\mathbf{\Lambda} = \begin{pmatrix} \lambda_1 & & 0 \\ & \ddots & \\ 0 & & \lambda_N \end{pmatrix}; \quad \gamma(\mathbf{\Lambda}) = \begin{pmatrix} \gamma(\lambda_1) & & 0 \\ & \ddots & \\ 0 & & \gamma(\lambda_N) \end{pmatrix}.$$

With the filtered coefficients, we can now reconstruct the signal to the graph domain using the Inverse Graph Fourier Transform (IGFT) as follows:

$$\mathbf{f}' = \mathbf{U} \hat{\mathbf{f}}' = \mathbf{U} \cdot \gamma(\mathbf{\Lambda}) \cdot \mathbf{U}^T \mathbf{f}, \quad (5.5)$$

where \mathbf{f}' is the obtained filtered graph signal. The filtering process can be regarded as applying the operator $\mathbf{U} \cdot \gamma(\mathbf{\Lambda}) \cdot \mathbf{U}^T$ to the input graph signal. For convenience, we sometimes refer the function $\gamma(\mathbf{\Lambda})$ as the filter since it controls how each frequency component of the graph signal \mathbf{f} is filtered. For example, in the extreme case, if $\gamma(\lambda_i)$ equals to 0, then, $\hat{\mathbf{f}}'[i] = 0$ and the frequency component \mathbf{u}_i is removed from the graph signal \mathbf{f} .

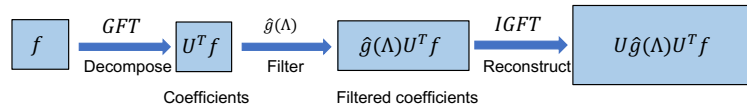

Figure 5.6 The Process of Spectral Filtering

Example 5.1 (Shuman et al., 2013) Suppose that we are given a noisy graph signal $\mathbf{y} = \mathbf{f}_0 + \eta$ defined on a graph \mathcal{G} , where η is uncorrelated additive Gaussian noise, we wish to recover the original signal \mathbf{f}_0 . The original signal \mathbf{f}_0 is assumed to be smooth with respect to the underlying graph \mathcal{G} . To enforce this prior information of the smoothness of the clean signal \mathbf{f}_0 , a regularization term of the form $\mathbf{f}^\top \mathbf{L} \mathbf{f}$ is included in the optimization problem as follows:

$$\arg \min_{\mathbf{f}} \|\mathbf{f} - \mathbf{y}\|^2 + c \mathbf{f}^\top \mathbf{L} \mathbf{f}, \quad (5.6)$$

where $c > 0$ is a constant to control the smoothness. The objective is convex; hence, the optimal solution \mathbf{f}' can be obtained by setting its derivative to 0 as follows:

$$\begin{aligned} 2(\mathbf{f} - \mathbf{y}) + 2c\mathbf{L}\mathbf{f} &= 0 \\ \Rightarrow (\mathbf{I} + c\mathbf{L})\mathbf{f} &= \mathbf{y} \\ \Rightarrow (\mathbf{U}\mathbf{U}^\top + c\mathbf{U}\mathbf{\Lambda}\mathbf{U}^\top)\mathbf{f} &= \mathbf{y} \\ \Rightarrow \mathbf{U}(\mathbf{I} + c\mathbf{\Lambda})\mathbf{U}^\top \mathbf{f} &= \mathbf{y} \\ \Rightarrow \mathbf{f}' &= \mathbf{U}(\mathbf{I} + c\mathbf{\Lambda})^{-1} \mathbf{U}^\top \mathbf{y}. \end{aligned} \quad (5.7)$$

Comparing Eq. (5.7) with Eq. (5.5), we can find that the cleaner signal is obtained by filtering the noisy signal \mathbf{y} with the filter $\gamma(\mathbf{\Lambda}) = (\mathbf{I} + c\mathbf{\Lambda})^{-1}$. For a specific frequency λ_l , the filter can be expressed as follows:

$$\gamma(\lambda_l) = \frac{1}{1 + c\lambda_l}, \quad (5.8)$$

which clearly indicates that $\gamma(\lambda_l)$ is a low-pass filter since $\gamma(\lambda_l)$ is large when λ_l is small and it is small when λ_l is large. Hence, solving the optimization problem in Eq.(5.6) is equivalent to applying the low-pass filter in Eq. (5.8) to the noisy signal \mathbf{y} .

Spectral-based Graph Filters

We have introduced the graph spectral filtering operator, which can be used to filter certain frequencies in the input signal. For example, if we want to get a smooth signal after filtering, we can design a low-pass filter, where $\gamma(\lambda)$ is large

when λ is small, and it is small when λ is large. In this way, the obtained filtered signal is smooth since it majorly contains the low-frequency part of the input signal. An example of the low-pass filter is shown in Example 5.1. If we know how we want to modulate the frequencies in the input signal, we can design the function $\gamma(\lambda)$ in a corresponding way. However, when utilizing the spectral-based filter as a graph filter in graph neural networks, we often do not know which frequencies are more important. Hence, just like the classical neural networks, the graph filters can be learned in a data-driven way. Specifically, we can model $\gamma(\Lambda)$ with certain functions and then learn the parameters with the supervision from data.

A natural attempt is to give full freedom when designing $\gamma()$ (or a non-parametric model). In detail, the function $\gamma()$ is defined as follows (Bruna et al., 2013):

$$\gamma(\lambda_l) = \theta_l,$$

where θ_l is a parameter to be learned from the data. It can also be represented in a matrix form as follows:

$$\gamma(\Lambda) = \begin{pmatrix} \theta_1 & & 0 \\ & \ddots & \\ 0 & & \theta_N \end{pmatrix}.$$

However, there are some limitations with this kind of filter. First, the number of parameters to be learned is equal to the number of nodes N , which can be extremely large in real-world graphs. Hence, it requires lots of memory to store these parameters and also abundant data to fit them. Second, the filter $\mathbf{U} \cdot \gamma(\Lambda) \cdot \mathbf{U}^\top$ is likely to be a dense matrix. Therefore, the calculation of the i -th element of the output signal \mathbf{f}' could relate to all the nodes in the graph. In other words, the operator is not spatially localized. Furthermore, the computational cost for this operator is quite expensive due to the eigendecomposition of the Laplacian matrix and the matrix multiplication between dense matrices when calculating $\mathbf{U} \cdot \gamma(\Lambda) \cdot \mathbf{U}^\top$.

To address these issues, a polynomial filter operator, which we denoted as Poly-Filter, is proposed in (Defferrard et al., 2016). The function $\gamma()$ can be modeled with a K -order truncated polynomial as follows:

$$\gamma(\lambda_l) = \sum_{k=0}^K \theta_k \lambda_l^k. \quad (5.9)$$

In terms of the matrix form, it can be rewritten as below:

$$\gamma(\mathbf{\Lambda}) = \sum_{k=0}^K \theta_k \mathbf{\Lambda}^k. \quad (5.10)$$

Clearly, the number of the parameters in Eq. (5.9) and Eq. (5.10) is $K + 1$, which is not dependent on the number of nodes in the graph. Furthermore, we can show that $\mathbf{U} \cdot \gamma(\mathbf{\Lambda}) \cdot \mathbf{U}^\top$ can be simplified to be a polynomial of the Laplacian matrix. It means that: 1) no eigendecomposition is needed; and 2) the polynomial parametrized filtering operator is spatially localized, i.e., the calculation of each element of the output \mathbf{f}' only involves a small number of nodes in the graph. Next, we first show that the Poly-Filter operator can be formulated as a polynomial of the Laplacian matrix and then understand it from a spatial perspective.

By applying this Poly-Filter operator on \mathbf{f} , according to Eq. (5.5), we can get the output \mathbf{f}' as follows:

$$\begin{aligned} \mathbf{f}' &= \mathbf{U} \cdot \gamma(\mathbf{\Lambda}) \cdot \mathbf{U}^\top \mathbf{f} \\ &= \mathbf{U} \cdot \sum_{k=0}^K \theta_k \mathbf{\Lambda}^k \cdot \mathbf{U}^\top \mathbf{f} \\ &= \sum_{k=0}^K \theta_k \mathbf{U} \cdot \mathbf{\Lambda}^k \cdot \mathbf{U}^\top \mathbf{f}. \end{aligned} \quad (5.11)$$

To further simplify Eq. (5.11), we first show that $\mathbf{U} \cdot \mathbf{\Lambda}^k \cdot \mathbf{U}^\top = \mathbf{L}^k$ as follows:

$$\begin{aligned} \mathbf{U} \cdot \mathbf{\Lambda}^k \cdot \mathbf{U}^\top &= \mathbf{U} \cdot (\mathbf{\Lambda} \mathbf{U}^\top \mathbf{U})^k \mathbf{U}^\top \\ &= \underbrace{(\mathbf{U} \cdot \mathbf{\Lambda} \cdot \mathbf{U}^\top) \cdots (\mathbf{U} \cdot \mathbf{\Lambda} \cdot \mathbf{U}^\top)}_k \\ &= \mathbf{L}^k. \end{aligned} \quad (5.12)$$

With Eq. (5.12), we can now simplify Eq. (5.11) as follows:

$$\begin{aligned} \mathbf{f}' &= \sum_{k=0}^K \theta_k \mathbf{U} \cdot \mathbf{\Lambda}^k \cdot \mathbf{U}^\top \mathbf{f} \\ &= \sum_{k=0}^K \theta_k \mathbf{L}^k \mathbf{f}. \end{aligned}$$

The polynomials of the Laplacian matrix are all sparse. Meanwhile, the i, j -th ($i \neq j$) element of \mathbf{L}^k is non-zero only when the length of the shortest path between node v_i and node v_j , i.e., $\text{dis}(v_i, v_j)$, is less or equal to k as described in the following lemma.

Lemma 5.2 *Let \mathcal{G} be a graph and \mathbf{L} be its Laplacian matrix. Then, the i, j -th element of the k -th power of the Laplacian matrix $\mathbf{L}_{i,j}^k = 0$ if $\text{dis}(v_i, v_j) > k$.*

Proof We prove this Lemma by induction. When $k = 1$, by the definition of the Laplacian matrix \mathbf{L} , we naturally have that $\mathbf{L}_{i,j} = 0$ if $\text{dis}(v_i, v_j) > 1$. Assume for $k = n$, we have that $\mathbf{L}_{i,j}^n = 0$ if $\text{dis}(v_i, v_j) > n$. We proceed to prove that for $k = n + 1$, we have $\mathbf{L}_{i,j}^{n+1} = 0$ if $\text{dis}(v_i, v_j) > n + 1$. Specifically, the element $\mathbf{L}_{i,j}^{n+1}$ can be represented using \mathbf{L}^n and \mathbf{L} as:

$$\mathbf{L}_{i,j}^{n+1} = \sum_{h=1}^N \mathbf{L}_{i,h}^n \mathbf{L}_{h,j}.$$

We next show that $\mathbf{L}_{i,h}^n \mathbf{L}_{h,j} = 0$ for $h = 1, \dots, N$, which indicates that $\mathbf{L}_{i,j}^{n+1} = 0$.

If $\mathbf{L}_{h,j} \neq 0$, then $\text{dis}(v_h, v_j) \leq 1$, i.e., either $h = j$ or there is an edge between node v_i and node v_j . If we have $d(v_i, v_h) \leq n$, then, with $\text{dis}(v_i, v_j) \leq 1$, we have $\text{dis}(v_i, v_j) \leq n + 1$, which contradicts the assumption. Hence, $\text{dis}(v_i, v_h) > n$ must hold. Thus, we have $\mathbf{L}_{i,h}^n = 0$, which means $\mathbf{L}_{i,h}^n \mathbf{L}_{h,j} = 0$.

If $\mathbf{L}_{h,j} = 0$, then $\mathbf{L}_{i,h}^n \mathbf{L}_{h,j} = 0$ also holds. Therefore, $\mathbf{L}_{i,j}^{n+1} = 0$ if $\text{dis}(v_i, v_j) > n + 1$, which completes the proof. \square

We now focus on a single element of the output signal \mathbf{f}' to observe how the calculation is related to other nodes in the graph. More specifically, the value of the output signal at the node v_i can be calculated as:

$$\mathbf{f}'[i] = \sum_{v_j \in \mathcal{V}} \left(\sum_{k=0}^K \theta_k \mathbf{L}_{i,j}^k \right) \mathbf{f}[j], \quad (5.13)$$

which can be regarded as a linear combination of the original signal on all the nodes according to the weight $\sum_{k=0}^K \theta_k \mathbf{L}_{i,j}^k$. According to Lemma 5.2, $\mathbf{L}_{i,j}^k = 0$ when $\text{dis}(v_i, v_j) > k$. Hence, not all the nodes are involved in this calculation, but only those nodes that are within K -hop of the node v_i are involved. We can reorganize Eq. (5.13) with only those nodes that are within K -hop neighborhood of node v_i as:

$$\mathbf{f}'[i] = b_{i,i} \mathbf{f}[i] + \sum_{v_j \in \mathcal{N}^K(v_i)} b_{i,j} \mathbf{f}[j], \quad (5.14)$$

where $\mathcal{N}^K(v_i)$ denotes all the nodes that are within K -hop neighborhood of the node v_i and the parameter $b_{i,j}$ is defined as:

$$b_{i,j} = \sum_{k=\text{dis}(v_i, v_j)}^K \theta_k \mathbf{L}_{i,j}^k,$$

where $\text{dis}(v_i, v_j)$ denotes the length of the shortest path between node v_i and node v_j . We can clearly observe that the Poly-Filter is localized in the spatial domain as it only involves K -hop neighborhoods when calculating the output signal value for a specific node. Furthermore, the Poly-Filter can be also regarded as a spatial-based graph filter as the filtering process can be described based on the spatial graph structure as shown in Eq. (5.14). A similar graph filter operation is proposed in (Atwood and Towsley, 2016). Instead of using the powers of Laplacian matrix, it linearly combines information aggregated from multi-hop neighbors of the center node with powers of the adjacency matrix.

While the Poly-Filter enjoys various advantages, there are still some limitations. One major issue is that the basis of the polynomial (i.e., $1, x, x^2, \dots$) is not orthogonal to each other. Hence, the coefficients are dependent on each other, making them unstable under perturbation during the learning process. In other words, an update in one coefficient may lead to changes in other coefficients. To address this issue, Chebyshev polynomial, which has a set of orthogonal basis, is utilized to model the filter (Defferrard et al., 2016). Next, we briefly discuss the Chebyshev polynomial and then detail the Cheby-Filter based on the Chebyshev polynomial.

Chebyshev Polynomial and Cheby-Filter

The Chebyshev polynomials $T_k(y)$ can be generated by the following recurrence relation:

$$T_k(y) = 2yT_{k-1}(y) - T_{k-2}(y), \quad (5.15)$$

with $T_0(y) = 1$ and $T_1(y) = y$, respectively. For $y \in [-1, 1]$, these Chebyshev polynomials can be represented in the trigonometric expression as:

$$T_k(y) = \cos(k \arccos(y)),$$

which means that each $T_k(y)$ is bounded in $[-1, 1]$. Furthermore, these Chebyshev polynomials satisfy the following relation:

$$\int_{-1}^1 \frac{T_l(y)T_m(y)}{\sqrt{1-y^2}} dy = \begin{cases} \delta_{l,m}\pi/2 & \text{if } m, l > 0, \\ \pi & \text{if } m = l = 0, \end{cases} \quad (5.16)$$

where $\delta_{l,m} = 1$ only when $l = m$, otherwise $\delta_{l,m} = 0$. Eq. (5.16) indicates that the Chebyshev polynomials are orthogonal to each other. Thus, the Chebyshev polynomials form an orthogonal basis for the Hilbert space of square integrable functions with respect to the measure $dy/\sqrt{1-y^2}$, which is denoted as $L^2([-1, 1], dy/\sqrt{1-y^2})$.

As the domain for the Chebyshev polynomials is $[-1, 1]$, to approximate the

filter with the Chebyshev polynomials, we rescale and shift the eigenvalues of the Laplacian matrix as follows:

$$\tilde{\lambda}_l = \frac{2 \cdot \lambda_l}{\lambda_{max}} - 1,$$

where $\lambda_{max} = \lambda_N$ is the largest eigenvalue of the Laplacian matrix. Clearly, all the eigenvalues are transformed to the range $[-1, 1]$ by this operation. Correspondingly, in the matrix form, the rescaled and shifted diagonal eigenvalue matrix is denoted as:

$$\tilde{\Lambda} = \frac{2\Lambda}{\lambda_{max}} - \mathbf{I},$$

where \mathbf{I} is the identity matrix. The Cheby-Filter, which is parameterized with the truncated Chebyshev polynomials can be formulated as follows:

$$\gamma(\Lambda) = \sum_{k=0}^K \theta_k T_k(\tilde{\Lambda}).$$

The process of applying the Cheby-Filter on a graph signal \mathbf{f} can be defined as:

$$\begin{aligned} \mathbf{f}' &= \mathbf{U} \cdot \sum_{k=0}^K \theta_k T_k(\tilde{\Lambda}) \mathbf{U}^T \mathbf{f} \\ &= \sum_{k=0}^K \theta_k \mathbf{U} T_k(\tilde{\Lambda}) \mathbf{U}^T \mathbf{f}. \end{aligned} \quad (5.17)$$

Next, we show that $\mathbf{U} T_k(\tilde{\Lambda}) \mathbf{U}^T = T_k(\tilde{\mathbf{L}})$ with $\tilde{\mathbf{L}} = \frac{2\mathbf{L}}{\lambda_{max}} - \mathbf{I}$ in the following theorem.

Theorem 5.3 For a graph \mathcal{G} with Laplacian matrix \mathbf{L} , the following equation holds for $k \geq 0$.

$$\mathbf{U} T_k(\tilde{\Lambda}) \mathbf{U}^T = T_k(\tilde{\mathbf{L}}),$$

where

$$\tilde{\mathbf{L}} = \frac{2\mathbf{L}}{\lambda_{max}} - \mathbf{I}.$$

Proof For $k = 0$, the equation holds as $\mathbf{U} T_0(\tilde{\Lambda}) \mathbf{U}^T = \mathbf{I} = T_0(\tilde{\mathbf{L}})$.

For $k = 1$,

$$\begin{aligned}
 \mathbf{U}T_1(\tilde{\Lambda})\mathbf{U}^\top &= \mathbf{U}\tilde{\Lambda}\mathbf{U}^\top \\
 &= \mathbf{U}\left(\frac{2\Lambda}{\lambda_{max}} - \mathbf{I}\right)\mathbf{U}^\top \\
 &= \frac{2\mathbf{L}}{\lambda_{max}} - \mathbf{I} \\
 &= T_1(\tilde{\mathbf{L}}).
 \end{aligned}$$

Hence, the equation also holds for $k = 1$.

Assume that the equation holds for $k = n - 2$ and $k = n - 1$ with $n \geq 2$, we show that the equation also holds for $k = n$ using the recursive relation in Eq. (5.15) as:

$$\begin{aligned}
 \mathbf{U}T_n(\tilde{\Lambda})\mathbf{U}^\top &= \mathbf{U}\left[2\tilde{\Lambda}T_{n-1}(\tilde{\Lambda}) - T_{n-2}(\tilde{\Lambda})\right]\mathbf{U}^\top \\
 &= 2\mathbf{U}\tilde{\Lambda}T_{n-1}(\tilde{\Lambda})\mathbf{U}^\top - \mathbf{U}T_{n-2}(\tilde{\Lambda})\mathbf{U}^\top \\
 &= 2\mathbf{U}\tilde{\Lambda}\mathbf{U}\mathbf{U}^\top T_{n-1}(\tilde{\Lambda})\mathbf{U}^\top - T_{n-2}(\tilde{\mathbf{L}}) \\
 &= 2\tilde{\mathbf{L}}T_{n-1}(\tilde{\mathbf{L}}) - T_{n-2}(\tilde{\mathbf{L}}) \\
 &= T_n(\tilde{\mathbf{L}}),
 \end{aligned}$$

which completes the proof. \square

With theorem 5.3, we can further simplify Eq. (5.17) as:

$$\begin{aligned}
 \mathbf{f}' &= \sum_{k=0}^K \theta_k \mathbf{U}T_k(\tilde{\Lambda})\mathbf{U}^\top \mathbf{f} \\
 &= \sum_{k=0}^K \theta_k T_k(\tilde{\mathbf{L}})\mathbf{f}
 \end{aligned}$$

Hence, the Cheby-Filter still enjoys the advantages of Poly-Filter while it is more stable under perturbations.

GCN-Filter: Simplified Cheby-Filter Involving 1-hop Neighbors

The Cheby-Filter involves a K -hop neighborhood of a node when calculating the new features for the node. In (Kipf and Welling, 2016a), a simplified Cheby-Filter named GCN-Filter is proposed. It is simplified from the Cheby-Filter by setting the order of Chebyshev polynomials to $K = 1$ and approximating $\lambda_{max} \approx 2$. Under this simplification and approximation, the Cheby-Filter

with $K = 1$ can be simplified as follows:

$$\begin{aligned}\gamma(\Lambda) &= \theta_0 T_0(\tilde{\Lambda}) + \theta_1 T_1(\tilde{\Lambda}) \\ &= \theta_0 \mathbf{I} + \theta_1 \tilde{\Lambda} \\ &= \theta_0 \mathbf{I} + \theta_1 (\Lambda - \mathbf{I}).\end{aligned}$$

Correspondingly, applying the GCN-Filter to a graph signal \mathbf{f} , we can get the output signal \mathbf{f}' as follows:

$$\begin{aligned}\mathbf{f}' &= \mathbf{U}\gamma(\Lambda)\mathbf{U}^\top \mathbf{f} \\ &= \theta_0 \mathbf{U}\mathbf{U}^\top \mathbf{f} + \theta_1 \mathbf{U}(\Lambda - \mathbf{I})\mathbf{U}^\top \mathbf{f} \\ &= \theta_0 \mathbf{f} - \theta_1 (\mathbf{L} - \mathbf{I})\mathbf{f} \\ &= \theta_0 \mathbf{f} - \theta_1 (\mathbf{D}^{-\frac{1}{2}} \mathbf{A} \mathbf{D}^{\frac{1}{2}})\mathbf{f}.\end{aligned}\tag{5.18}$$

Note that Eq. (5.18) holds as the normalized Laplacian matrix as defined in Definition 2.29 is adopted, i.e. $\mathbf{L} = \mathbf{I} - \mathbf{D}^{-\frac{1}{2}} \mathbf{A} \mathbf{D}^{-\frac{1}{2}}$. A further simplification is applied to Eq. (5.18) by setting $\theta = \theta_0 = -\theta_1$, which leads to

$$\begin{aligned}\mathbf{f}' &= \theta_0 \mathbf{f} - \theta_1 (\mathbf{D}^{-\frac{1}{2}} \mathbf{A} \mathbf{D}^{\frac{1}{2}})\mathbf{f} \\ &= \theta (\mathbf{I} + \mathbf{D}^{-\frac{1}{2}} \mathbf{A} \mathbf{D}^{-\frac{1}{2}})\mathbf{f}.\end{aligned}\tag{5.19}$$

Note that the matrix $\mathbf{I} + \mathbf{D}^{-\frac{1}{2}} \mathbf{A} \mathbf{D}^{-\frac{1}{2}}$ has eigenvalues in the range $[0, 2]$, which may lead to numerical instabilities when this operator is repeatedly applied to a specific signal \mathbf{f} . Hence, a renormalization trick is proposed to alleviate this problem, which uses $\tilde{\mathbf{D}}^{-\frac{1}{2}} \tilde{\mathbf{A}} \tilde{\mathbf{D}}^{-\frac{1}{2}}$ to replace the matrix $\mathbf{I} + \mathbf{D}^{-\frac{1}{2}} \mathbf{A} \mathbf{D}^{-\frac{1}{2}}$ in Eq. (5.19), where $\tilde{\mathbf{A}} = \mathbf{A} + \mathbf{I}$ and $\tilde{\mathbf{D}}_{ii} = \sum_j \tilde{\mathbf{A}}_{i,j}$. The final GCN-Filter after these simplifications is defined as:

$$\mathbf{f}' = \theta \tilde{\mathbf{D}}^{-\frac{1}{2}} \tilde{\mathbf{A}} \tilde{\mathbf{D}}^{-\frac{1}{2}} \mathbf{f}.\tag{5.20}$$

The i, j -th element of $\tilde{\mathbf{D}}^{-\frac{1}{2}} \tilde{\mathbf{A}} \tilde{\mathbf{D}}^{-\frac{1}{2}}$ is non-zero only when nodes v_i and v_j are connected. For a single node, this process can be viewed as aggregating information from its 1-hop neighbors where the node itself is also regarded as its 1-hop neighbor. Thus, the GCN-Filter can also be viewed as a spatial-based filter, which only involves directly connected neighbors when updating node features.

Graph Filters for Multi-channel Graph Signals

We have introduced the graph filters for 1-channel graph signals, where each node is associated with a single scalar value. However, in practice, graph signals are typically multi-channel, where each node has a vector of features. A

multi-channel graph signals with d_{in} dimensions can be denoted as $\mathbf{F} \in \mathbb{R}^{N \times d_{in}}$. To extend the graph filters to the multi-channel signals, we utilize the signals from all the input channels to generate the output signal as follows:

$$\mathbf{f}_{out} = \sum_{d=1}^{d_{in}} \mathbf{U} \cdot \gamma_d(\Lambda) \cdot \mathbf{U}^T \mathbf{F}_{:,d}$$

where $\mathbf{f}_{out} \in \mathbb{R}^N$ is the 1-channel output signal of the filter and $\mathbf{F}_{:,d} \in \mathbb{R}^N$ denotes the d -th channel of the input signal. Thus, the process can be viewed as applying the graph filter in each input channel and then calculating the summation of their results. Just as the classical convolutional neural networks, in most of the cases, multiple filters are used to filter the input channels and the output is also a multi-channel signal. Suppose that we use d_{out} filters, the process to generate the d_{out} -channel output signal is defined as:

$$\mathbf{F}'_{:,j} = \sum_{d=1}^{d_{in}} \mathbf{U} \cdot \gamma_{j,d}(\Lambda) \cdot \mathbf{U}^T \mathbf{F}_{:,d} \quad \text{for } j = 1, \dots, d_{out}.$$

Specifically, in the case of GCN-Filter in Eq. (5.20), this process for multi-channel input and output can be simply represented as:

$$\mathbf{F}'_{:,j} = \sum_{d=1}^{d_{in}} \theta_{j,d} \tilde{\mathbf{D}}^{-\frac{1}{2}} \tilde{\mathbf{A}} \tilde{\mathbf{D}}^{-\frac{1}{2}} \mathbf{F}_{:,d} \quad \text{for } j = 1, \dots, d_{out},$$

which can be further rewritten in a matrix form as:

$$\mathbf{F}' = \tilde{\mathbf{D}}^{-\frac{1}{2}} \tilde{\mathbf{A}} \tilde{\mathbf{D}}^{-\frac{1}{2}} \mathbf{F} \Theta \quad (5.21)$$

where $\Theta \in \mathbb{R}^{d_{in} \times d_{out}}$ and $\Theta_{d,j} = \theta_{j,d}$ is the parameter corresponding to the j -th output channel and d -th input channel. Specifically, for a single node v_i , the filtering process in Eq. (5.21) can also be formulated in the following form:

$$\mathbf{F}'_i = \sum_{v_j \in \mathcal{N}(v_i) \cup \{v_i\}} \left(\tilde{\mathbf{D}}^{-\frac{1}{2}} \tilde{\mathbf{A}} \tilde{\mathbf{D}}^{-\frac{1}{2}} \right)_{i,j} \mathbf{F}_j \Theta = \sum_{v_j \in \mathcal{N}(v_i) \cup \{v_i\}} \frac{1}{\sqrt{\tilde{d}_i \tilde{d}_j}} \mathbf{F}_j \Theta, \quad (5.22)$$

where $\tilde{d}_i = \tilde{\mathbf{D}}_{i,i}$ and we use $\mathbf{F}_i \in \mathbb{R}^{1 \times d_{out}}$ to denote the i -th row of \mathbf{F} , i.e., the features for node v_i . The process in Eq. (5.22) can be regarded as aggregating information from 1-hop neighbors of node v_i .

5.3.2 Spatial-based Graph Filters

As shown in Eq. (5.22), for a node v_i , the GCN-Filter performs a spatial information aggregation involving 1-hop neighbors and the matrix Θ consisting of parameters for the filters can be regarded as a linear transformation applying to

the input node features. In fact, spatial-based filters in graph neural networks have been proposed even before deep learning became popular (Scarselli et al., 2005). More recently, A variety of spatial-based filters have been designed for graph neural networks. In this section, we review the very first spatial filter (Scarselli et al., 2005, 2008) and then more advanced spatial-based filters.

The filter in the very first graph neural network

The concept of graph neural networks was first proposed in (Scarselli et al., 2008). This GNN model iteratively updates features of one node by utilizing features of its neighbors. Next, we briefly introduce the design of the filter in the very first GNN model. Specifically, the model is proposed to deal with graph data where each node is associated with an input label. For node v_i , its corresponding label can be denoted as l_i . For the filtering process, the input graph feature is denoted as \mathbf{F} , where \mathbf{F}_i , i.e., the i -th row of \mathbf{F} , is the associated features for node v_i . The output features of the filter are represented as \mathbf{F}' . The filtering operation for node v_i can be described as:

$$\mathbf{F}'_i = \sum_{v_j \in \mathcal{N}(v_i)} g(l_i, \mathbf{F}_j, l_j),$$

where $g()$ is a parametric function, called *local transition function*, which is spatially localized. The filtering process for node v_i only involves its 1-hop neighbors. Typically $g()$ can be modeled by feedforward neural networks. The function $g()$ is shared by all the nodes in the graph when performing the filtering process. Note that the node label information l_i can be viewed as the initial input information, which is fixed and utilized in the filtering process.

GraphSAGE-Filter

The GraphSAGE model proposed in (Hamilton et al., 2017a) introduced a spatial based filter, which is also based on aggregating information from neighboring nodes. For a single node v_i , the process to generate its new features can be formulated as follows:

$$\mathcal{N}_S(v_i) = \text{SAMPLE}(\mathcal{N}(v_i), S) \tag{5.23}$$

$$\mathbf{f}'_{\mathcal{N}_S(v_i)} = \text{AGGREGATE}(\{\mathbf{F}_j, \forall v_j \in \mathcal{N}_S(v_i)\}) \tag{5.24}$$

$$\mathbf{F}'_i = \sigma([\mathbf{F}_i, \mathbf{f}'_{\mathcal{N}_S(v_i)}] \Theta) \tag{5.25}$$

where $\text{SAMPLE}()$ is a function that takes a set as input and randomly samples S elements from the input as output, $\text{AGGREGATE}()$ is a function to combine the information from the neighboring nodes where $\mathbf{f}'_{\mathcal{N}_S(v_i)}$ denotes the output of the $\text{AGGREGATE}()$ function and $[\cdot, \cdot]$ is the concatenation operation. Hence,

for a single node v_i , the filter in GraphSAGE first samples S nodes from its neighboring nodes $\mathcal{N}(v_i)$ as shown in Eq. (5.23). Then, the AGGREGATE() function aggregates the information from these sampled nodes and generates the feature $\mathbf{f}'_{\mathcal{N}_S(v_i)}$ as shown in Eq. (5.24). Finally, the generated neighborhood information and the old features of node v_i are combined to generate the new features for node v_i as shown in Eq. (5.25). Various AGGREGATE() functions have been introduced in (Hamilton et al., 2017a) as below.

- **Mean aggregator.** The mean aggregator is to simply take element-wise mean of the vectors in $\{\mathbf{F}_j, \forall v_j \in \mathcal{N}_S(v_i)\}$. The mean aggregator here is very similar to the filter in GCN. When dealing with a node v_i , both of them take the (weighted) average of the neighboring nodes as its new representation. The difference is how the input representation \mathbf{F}_j of node v_j gets involved in the calculation. It is clear that in GraphSAGE, \mathbf{F}_i is concatenated to the aggregated neighboring information $\mathbf{f}'_{\mathcal{N}_S(v_i)}$. However, in the GCN-Filter, the node v_i is treated equally as its neighbors and \mathbf{F}_i is a part of the weighted average process.
- **LSTM aggregator.** The LSTM aggregator is to treat the set of the sampled neighboring nodes $\mathcal{N}_S(v_i)$ of node v_i as a sequence and utilize the LSTM architecture to process the sequence. The output of the last unit of the LSTM serves as the result $\mathbf{f}'_{\mathcal{N}_S(v_i)}$. However, there is no natural order among the neighbors; hence, a random ordering is adopted in (Hamilton et al., 2017a).
- **Pooling operator.** The pooling operator adopts the max pooling operation to summarize the information from the neighboring nodes. Before summarizing the results, input features at each node are first transformed with a layer of a neural network. The process can be described as follows

$$\mathbf{f}'_{\mathcal{N}_S(v_i)} = \max(\{\alpha(\mathbf{F}_j \mathbf{\Theta}_{\text{pool}}), \forall v_j \in \mathcal{N}_S(v_i)\}),$$

where $\max()$ denotes the element-wise max operator, $\mathbf{\Theta}_{\text{pool}}$ denotes a transformation matrix and $\alpha()$ is a non-linear activation function.

The GraphSAGE-Filter is spatially localized as it only involves 1-hop neighbors no matter which aggregator is used. The aggregator is also shared among all the nodes.

GAT-Filter

Self-attention mechanism (Vaswani et al., 2017) is introduced to build spatial graph filters in graph attention networks (GAT) (Veličković et al., 2017). For convenience, we call the graph filter in GAT as GAT-Filter. The GAT-Filter is similar to the GCN-Filter since it also performs an information aggregation

from neighboring nodes when generating new features for each node. The aggregation in GCN-Filter is solely based on the graph structure, while GAT-filter tries to differentiate the importance of the neighbors when performing the aggregation. More specifically, when generating the new features for a node v_i , it attends to all its neighbors to generate an importance score for each neighbor. These importance scores are then adopted as linear coefficients during the aggregation process. Next, we detail the GAT-Filter.

The importance score of node $v_j \in \mathcal{N}(v_i) \cup \{v_i\}$ to the node v_i can be calculated as follows:

$$e_{ij} = a(\mathbf{F}_i \Theta, \mathbf{F}_j \Theta), \quad (5.26)$$

where Θ is a shared parameter matrix. $a()$ is a shared attention function which is a single-layer feedforward network in (Veličković et al., 2017) as:

$$a(\mathbf{F}_i \Theta, \mathbf{F}_j \Theta) = \text{LeakyReLU}(\mathbf{a}^\top [\mathbf{F}_i \Theta, \mathbf{F}_j \Theta]),$$

where $[\cdot, \cdot]$ denotes the concatenation operation, \mathbf{a} is a parametrized vector and LeakyReLU is the nonlinear activation function we have introduced in Section 3.2.2. The scores calculated by Eq. (5.26) are then normalized before being utilized as the weights in the aggregation process to keep the output representation in a reasonable scale. The normalization over all neighbors of v_i is performed through a softmax layer as:

$$\alpha_{ij} = \frac{\exp(e_{ij})}{\sum_{v_k \in \mathcal{N}(v_i) \cup \{v_i\}} \exp(e_{ik})},$$

where α_{ij} is the normalized importance score indicating the importance of node v_j to node v_i . With the normalized importance scores, the new representation \mathbf{F}'_i of node v_i can be computed as:

$$\mathbf{F}'_i = \sum_{v_j \in \mathcal{N}(v_i) \cup \{v_i\}} \alpha_{ij} \mathbf{F}_j \Theta, \quad (5.27)$$

where Θ is the same transforming matrix as in Eq. (5.26). To stabilize the learning process of self-attention, the multi-head attention (Vaswani et al., 2017) is adopted. Specifically, M independent attention mechanisms in the form of Eq. (5.27) with different Θ^m and α_{ij}^m are performed in parallel. Their outputs are then concatenated to generate the final representation of node v_i as:

$$\mathbf{F}'_i = \parallel_{m=1}^M \sum_{v_j \in \mathcal{N}(v_i) \cup \{v_i\}} \alpha_{ij}^m \mathbf{F}_j \Theta^m, \quad (5.28)$$

where we use \parallel to denote the concatenation operator. Note that the GAT-Filter is spatially localized, as for each node, only its 1-hop neighbors are

utilized in the filtering process to generate the new features. In the original model (Veličković et al., 2017), activation functions are applied to the output of each attention head before the concatenation. The formulation in Eq. (5.28) did not include activation functions for convenience.

ECC-Filter

When there is edge information available in the graph, it can be utilized for designing the graph filters. Specifically, in (Simonovsky and Komodakis, 2017), an edge-conditioned graph filter (ECC-Filter) is designed when edges have various types (the number of types is finite). For a given edge (v_i, v_j) , we use $tp(v_i, v_j)$ to denote its type. Then the ECC-Filter is defined as:

$$\mathbf{F}'_i = \frac{1}{|\mathcal{N}(v_i)|} \sum_{v_j \in \mathcal{N}(v_i)} \mathbf{F}_j \Theta_{tp(v_i, v_j)},$$

where $\Theta_{tp(v_i, v_j)}$ is the parameter matrix shared by the edges with the type of $tp(v_i, v_j)$.

GGNN-Filter

The GGNN-Filter (Li et al., 2015) adapts the original GNN filter in (Scarselli et al., 2008) with Gated Recurrent Unit (GRU) (see Section 3.4 for details of GRU). The GGNN-Filter is designed for graphs where the edges are directed and also have different types. Specifically, for an edge $(v_i, v_j) \in \mathcal{E}$, we use $tp(v_i, v_j)$ to denote its types. Note that, as the edges are directed, the types of edges (v_i, v_j) and (v_j, v_i) can be different, i.e., $tp(v_i, v_j) \neq tp(v_j, v_i)$. The filtering process of the GGNN-Filter for a specific node v_i can be formulated as follows:

$$\mathbf{m}_i = \sum_{(v_j, v_i) \in \mathcal{E}} \mathbf{F}_j \Theta_{tp(v_j, v_i)}^e \quad (5.29)$$

$$\mathbf{z}_i = \sigma(\mathbf{m}_i \Theta^z + \mathbf{F}_i \mathbf{U}^z) \quad (5.30)$$

$$\mathbf{r}_i = \sigma(\mathbf{m}_i \Theta^r + \mathbf{F}_i \mathbf{U}^r) \quad (5.31)$$

$$\tilde{\mathbf{F}}_i = \tanh(\mathbf{m}_i \Theta + (\mathbf{r}_i \odot \mathbf{F}_i) \mathbf{U}) \quad (5.32)$$

$$\mathbf{F}'_i = (1 - \mathbf{z}_i) \odot \mathbf{F}_i + \mathbf{z}_i \odot \tilde{\mathbf{F}}_i \quad (5.33)$$

where $\Theta_{tp(v_j, v_i)}^e$, Θ^z , Θ^r and Θ are parameters to be learned. The first step as in Eq. (5.29) is to aggregate information from both the in-neighbors and out-neighbors of node v_i . During this aggregation, the transform matrix $\Theta_{tp(v_j, v_i)}^e$ is shared by all the nodes connected to v_i via the edge type $tp(v_j, v_i)$. The remaining equations (or Eqs. (5.30)-(5.33)) are GRU steps to update the hidden representations with the aggregated information \mathbf{m}_i . \mathbf{z}_i and \mathbf{r}_i are the update and

reset gates, $\sigma(\cdot)$ is the sigmoid function and \odot denotes the Hardmand operation. Hence, the GGNN-Filter can also be written as:

$$\mathbf{m}_i = \sum_{(v_j, v_i) \in \mathcal{E}} \mathbf{F}_j \Theta_{lp(v_j, v_i)}^e \quad (5.34)$$

$$\mathbf{F}'_i = \text{GRU}(\mathbf{m}_i, \mathbf{F}_i) \quad (5.35)$$

where Eq. (5.35) summarizes Eqs. (5.30) to (5.33).

Mo-Filter

In (Monti et al., 2017), a general framework, i.e., mixture model networks (MoNet), is introduced to perform convolution operations on non-Euclidean data such as graphs and manifolds. Next, we introduce the graph filtering operation in (Monti et al., 2017), which we name as the Mo-Filter. We take node v_i as an example to illustrate its process. For each neighbor $v_j \in \mathcal{N}(v_i)$, a pseudo-coordinate is introduced to denote the relevant relation between nodes v_j and v_i . Specifically, for the center node v_i and its neighbor v_j , the pseudo-coordinate is defined with their degrees as:

$$c(v_i, v_j) = \left(\frac{1}{\sqrt{d_i}}, \frac{1}{\sqrt{d_j}} \right)^\top, \quad (5.36)$$

where d_i and d_j denote the degree of nodes v_i and v_j , respectively. Then a Gaussian kernel is applied on the pseudo-coordinate to measure the relation between the two nodes as:

$$\alpha_{i,j} = \exp\left(-\frac{1}{2}(c(v_i, v_j) - \mu)^\top \Sigma^{-1}(c(v_i, v_j) - \mu)\right), \quad (5.37)$$

where μ and Σ are the mean vector and the covariance matrix of the Gaussian kernel to be learned. Note that instead of using the original pseudo-coordinate, we can also utilize a feedforward network to first transform $c(v_i, v_j)$. The aggregation process is as:

$$\mathbf{F}'_i = \sum_{v_j \in \mathcal{N}(v_i)} \alpha_{i,j} \mathbf{F}_j. \quad (5.38)$$

In Eq. (5.38), a single Gaussian kernel is used. However, typically, a set of K kernels with different means and covariances are adopted, which results in the following process:

$$\mathbf{F}'_i = \sum_{k=1}^K \sum_{v_j \in \mathcal{N}(v_i)} \alpha_{i,j}^{(k)} \mathbf{F}_j,$$

where $\alpha_{i,j}^{(k)}$ is from the k -th Gaussian kernel.

MPNN: A General Framework for Spatial-based Graph Filters

Message Passing Neural Networks (MPNN) is a general GNN framework. Many spatial-based graph filters including GCN-Filter, GraphSAGE-Filter and GAT-Filter, are its special cases (Gilmer et al., 2017). For a node v_i , the MPNN-Filter updates its features as follows:

$$\mathbf{m}_i = \sum_{v_j \in \mathcal{N}(v_i)} M(\mathbf{F}_i, \mathbf{F}_j, \mathbf{e}_{(v_i, v_j)}), \quad (5.39)$$

$$\mathbf{F}'_i = U(\mathbf{F}_i, \mathbf{m}_i), \quad (5.40)$$

where $M()$ is the message function, $U()$ is the update function and $\mathbf{e}_{(v_i, v_j)}$ is edge features if available. The message function $M()$ generates the messages to pass to node v_i from its neighbors. The update function $U()$ then updates the features of node v_i by combining the original features and the aggregated message from its neighbors. The framework can be even more general if we replace the summation operation in Eq. (5.39) with other aggregation operations.

5.4 Graph Pooling

The graph filters refine the node features without changing the graph structure. After the graph filter operation, each node in the graph has a new feature representation. Typically, the graph filter operations are sufficient for node-focused tasks that take advantage of the node representations. However, for graph-focused tasks, a representation of the entire graph is desired. To obtain such representation, we need to summarize the information from the nodes. There are two main kinds of information that are important for generating the graph representation – one is the node features, and the other is the graph structure. The graph representation is expected to preserve both the node feature information and the graph structure information. Similar to the classical convolutional neural networks, graph pooling layers are proposed to generate graph level representations. The early designs of graph pooling layers are usually flat. In other words, they generate the graph-level representation directly from the node representations in a single step. For example, the average pooling layers and max-pooling layers can be adapted to graph neural networks by applying them to each feature channel. Later on, hierarchical graph pooling designs have been developed to summarize the graph information by coarsening the original graph step by step. In the hierarchical graph pooling design, there are often several graph pooling layers, each of which follows a stack of several filters, as shown in Figure 5.5. Typically, a single graph pooling layer

(both in the flat and the hierarchical cases) takes a graph as input and output a coarsened graph. Recall that the process has been summarized by Eq.(5.2) as:

$$\mathbf{A}^{(\text{op})}, \mathbf{F}^{(\text{op})} = \text{pool}(\mathbf{A}^{(\text{ip})}, \mathbf{F}^{(\text{ip})}), \quad (5.41)$$

Next, we first describe representative flat pooling layers and then introduce hierarchical pooling layers.

5.4.1 Flat Graph Pooling

A flat pooling layer directly generates a graph-level representation from the node representations. In flat pooling layers, there is no new graph but a single node being generated. Thus, instead of Eq.(5.41), the pooling process in flat pooling layers can be summarized as:

$$\mathbf{f}_{\mathcal{G}} = \text{pool}(\mathbf{A}^{(\text{ip})}, \mathbf{F}^{(\text{ip})}),$$

where $\mathbf{f}_{\mathcal{G}} \in \mathbb{R}^{1 \times d_{\text{op}}}$ is the graph representation. Next, we introduce some representative flat pooling layers. The max-pooling and average pooling operations in classical CNNs can be adapted to GNNs. Specifically, the operation of graph max-pooling layer can be expressed as:

$$\mathbf{f}_{\mathcal{G}} = \max(\mathbf{F}^{(\text{ip})}),$$

where the max operation is applied to each channel as follows:

$$\mathbf{f}_{\mathcal{G}}[i] = \max(\mathbf{F}_{:,i}^{(\text{ip})}),$$

where $\mathbf{F}_{:,i}^{(\text{ip})}$ denotes the i -th channel of $\mathbf{F}^{(\text{ip})}$. Similarly, graph average pooling operation applies the average pooling operation channel-wisely as:

$$\mathbf{f}_{\mathcal{G}} = \text{ave}(\mathbf{F}^{(\text{ip})}).$$

In (Li et al., 2015), an attention-based flat pooling operation, which is named as gated global pooling, is proposed. An attention score measuring the importance of each node is utilized to summarize the node representations for generating the graph representation. Specifically, the attention score for node v_i is computed as:

$$s_i = \frac{\exp(h(\mathbf{F}_i^{(\text{ip})}))}{\sum_{v_j \in \mathcal{V}} \exp(h(\mathbf{F}_j^{(\text{ip})}))},$$

where h is a feedforward network to map $\mathbf{F}_i^{(\text{ip})}$ to a scalar, which is then normalized through softmax. With the learned attention scores, the graph representation can be summarized from the node representations as:

$$\mathbf{f}_{\mathcal{G}} = \sum_{v_i \in \mathcal{V}} s_i \cdot \tanh(\mathbf{F}_i^{(\text{ip})} \Theta_{ip}),$$

where Θ_{ip} are parameters to be learned and the activation function $\tanh()$ can be also replaced with the identity function.

Some flat graph pooling operations are embedded in the design of the filtering layer. A “fake” node is added to the graph that is connected to all the nodes (Li et al., 2015). The representation of this “fake” node can be learned during the filtering process. Its representation captures the information of the entire graph as it is connected to all nodes in the graph. Hence, the representation of the “fake” node can be leveraged as the graph representation for downstream tasks.

5.4.2 Hierarchical Graph Pooling

Flat pooling layers usually ignore the hierarchical graph structure information when summarizing the node representations for the graph representation. Hierarchical graph pooling layers aim to preserve the hierarchical graph structural information by coarsening the graph step by step until the graph representation is achieved. Hierarchical pooling layers can be roughly grouped according to the ways they coarsen the graph. One type of hierarchical pooling layers coarsens the graph by sub-sampling, i.e., selecting the most important nodes as the nodes for the coarsened graph. A different kind of hierarchical pooling layer combines nodes in the input graph to form supernodes that serve as the nodes for the coarsened graph. The main difference between these two types of coarsening methods is that the sub-sampling based methods keep nodes from the original graph while the supernode-based methods generate new nodes for the coarsened graph. Next, we describe some representative techniques in these two categories. Specifically, we elaborate on the process of hierarchical pooling layers in Eq. (5.41) by explaining how the coarsened graph $\mathbf{A}^{(\text{op})}$ and node features $\mathbf{F}^{(\text{op})}$ are generated.

Downsampling-based Pooling

To coarsen the input graph, a set of N_{op} nodes are selected according to some importance measures, and then graph structure and node features for the coarsened graph are formed upon these nodes. There are three key components in a

downsampling based graph pooling layer: 1) developing the measure for downsampling; 2) generating graph structure for the coarsened graph and 3) generating node features for the coarsened graph. Different downsampling based pooling layers usually have distinct designs in these components. Next, we introduce representative downsampling based graph pooling layers.

The gPool layer (Gao and Ji, 2019) is the first to adopt the downsampling strategy to perform graph coarsening for graph pooling. In gPool, the importance measure for nodes is learned from the input node features $\mathbf{F}^{(ip)}$ as:

$$\mathbf{y} = \frac{\mathbf{F}^{(ip)} \mathbf{p}}{\|\mathbf{p}\|}, \quad (5.42)$$

where $\mathbf{F}^{(ip)} \in \mathbb{R}^{N_p \times d_p}$ is the matrix denoting the input node features and $\mathbf{p} \in \mathbb{R}^{d_p}$ is a vector to be learned to project the input features into importance scores. After obtaining the importance scores \mathbf{y} , we can rank all the nodes and select the N_{op} most important ones as:

$$\text{idx} = \text{rank}(\mathbf{y}, N_{op}),$$

where N_{op} is the number of nodes in the coarsened graph and idx denotes the indices of the selected top N_{op} nodes. With the selected nodes represented with their indices idx , we proceed to generate the graph structure and node features for the coarsened graph. Specifically, the graph structure for the coarsened graph can be induced from the graph structure of the input graph as:

$$\mathbf{A}^{(op)} = \mathbf{A}^{(ip)}(\text{idx}, \text{idx}),$$

where $\mathbf{A}^{(ip)}(\text{idx}, \text{idx})$ performs row and column extraction from $\mathbf{A}^{(ip)}$ with the selected indices idx . Similarly, the node features can also be extracted from the input node features. In (Gao and Ji, 2019), gating system is adopted to control the information flow from the input features to the new features. Specifically, the selected nodes with a higher importance score can have more information flow to the coarsened graph, which can be modeled as:

$$\begin{aligned} \tilde{\mathbf{y}} &= \sigma(\mathbf{y}(\text{idx})) \\ \tilde{\mathbf{F}} &= \mathbf{F}^{(ip)}(\text{idx}, :) \\ \mathbf{F}_p &= \tilde{\mathbf{F}} \odot (\tilde{\mathbf{y}} \mathbf{1}_{d_p}^T), \end{aligned}$$

where $\sigma()$ is the sigmoid function mapping the importance score to $(0, 1)$ and $\mathbf{1}_{d_p} \in \mathbb{R}^{d_p}$ is a all-ones vector. Note that $\mathbf{y}(\text{idx})$ extracts the corresponding elements from \mathbf{y} according to the indices in idx and $\mathbf{F}^{(ip)}(\text{idx}, :)$ retrieves the the corresponding rows according to idx .

In gPool, the importance score is learned solely based on the input features,

as shown in Eq. (5.42). It ignores the graph structure information. To incorporate the graph structure information when learning the importance score, the GCN-Filter is utilized to learn the importance score in (Lee et al., 2019). Specifically, the importance score can be obtained as follows:

$$\mathbf{y} = \alpha \left(\text{GCN-Filter}(\mathbf{A}^{(\text{ip})}, \mathbf{F}^{(\text{ip})}) \right). \quad (5.43)$$

where α is an activation function such as \tanh . Note that \mathbf{y} is a vector instead of a matrix. In other words, the number of the output channel of the GCN-Filter is set to 1. This graph pooling operation is named as the SAGPool.

Supernode-based Hierarchical Graph Pooling

The downsampling based hierarchical graph pooling layers try to coarsen the input graph by selecting a subset of nodes according to some importance measures. During the process, the information about the unselected nodes is lost as these nodes are discarded. Supernode-based pooling methods aim to coarsen the input graph by generating supernodes. Specifically, they try to learn to assign the nodes in the input graph into different clusters, where these clusters are treated as supernodes. These supernodes are regarded as the nodes in the coarsened graph. The edges between the supernodes and the features of these supernodes are then generated to form the coarsened graph. There are three key components in a supernode-based graph pooling layer: 1) generating supernodes as the nodes for the coarsened graph; 2) generating graph structure for the coarsened graph; and 3) generating node features for the coarsened graph. Next, we describe some representative supernode based graph pooling layers.

diffpool

The diffpool algorithm generates the supernodes in a differentiable way. In detail, a soft assignment matrix from the nodes in the input graph to the supernodes is learned using GCN-Filter as:

$$\mathbf{S} = \text{softmax} \left(\text{GCN-Filter}(\mathbf{A}^{(\text{ip})}, \mathbf{F}^{(\text{ip})}) \right), \quad (5.44)$$

where $\mathbf{S} \in \mathbb{R}^{N_{\text{ip}} \times N_{\text{op}}}$ is the assignment matrix to be learned. Note that as shown in Eq. (5.3), $\mathbf{F}^{(\text{ip})}$ is usually the output of the latest graph filtering layer. However, in (Ying et al., 2018c), the input of the pooling layer is the output of the previous pooling layer, i.e., the input of a learning block $\mathbf{F}^{(\text{ib})}$ (see details on *block* in Section 5.2.2). Furthermore, several GCN-Filters can be stacked to learn the assignment matrix, though only a single filter is utilized in Eq. (5.44). Each column of the assignment matrix can be regarded as a supernode. The softmax function is applied row-wisely; hence, each row is normalized to have

a summation of 1. The j -th element in the i -th row indicates the probability of assigning the i -th node to the j -th supernode. With the assignment matrix \mathbf{S} , we can proceed to generate the graph structure and node features for the coarsened graph. Specifically, the graph structure for the coarsened graph can be generated from the input graph by leveraging the soft assignment matrix \mathbf{S} as:

$$\mathbf{A}^{(\text{op})} = \mathbf{S}^\top \mathbf{A}^{(\text{ip})} \mathbf{S} \in \mathbb{R}^{N_{\text{op}} \times N_{\text{op}}}.$$

Similarly, the node features for the supernodes can be obtained by linearly combining the node features of the input graph according to the assignment matrix \mathbf{S} as:

$$\mathbf{F}^{(\text{op})} = \mathbf{S}^\top \mathbf{F}^{(\text{inter})} \in \mathbb{R}^{N_{\text{op}} \times d_{\text{op}}},$$

where $\mathbf{F}^{(\text{inter})} \in \mathbb{R}^{N_{\text{ip}} \times d_{\text{op}}}$ is the intermediate features learned through GCN-Filters as follows:

$$\mathbf{F}^{(\text{inter})} = \text{GCN-Filter}(\mathbf{A}^{(\text{ip})}, \mathbf{F}^{(\text{ip})}). \quad (5.45)$$

Multiple GCN-Filters can be stacked though only one is shown in Eq. (5.45). The process of diffpool can be summarized as:

$$\mathbf{A}^{(\text{op})}, \mathbf{F}^{(\text{op})} = \text{diffpool}(\mathbf{A}^{(\text{ip})}, \mathbf{F}^{(\text{ip})}).$$

EigenPooling

EigenPooling (Ma et al., 2019b) generates the supernodes using spectral clustering methods and focuses on forming graph structure and node features for the coarsened graph. After applying the spectral clustering algorithm, a set of non-overlapping clusters are obtained, which are also regarded as the supernodes for the coarsened graph. The assignment matrix between the nodes of the input graph and the supernodes can be denoted as $\mathbf{S} \in \{0, 1\}^{N_{\text{ip}} \times N_{\text{op}}}$, where only a single element in each row is 1 and all others are 0. More specifically, $S_{i,j} = 1$ only when the i -th node is assigned to the j -th supernode. For the k -th supernode, we use $\mathbf{A}^{(k)} \in \mathbb{R}^{N^{(k)} \times N^{(k)}}$ to describe the graph structure in its corresponding cluster, where $N^{(k)}$ is the number of nodes in this cluster. We define a sampling operator $\mathbf{C}^{(k)} \in \{0, 1\}^{N_{\text{ip}} \times N^{(k)}}$ as:

$$C_{i,j}^{(k)} = 1 \quad \text{if and only if} \quad \Gamma^{(k)}(j) = v_i,$$

where $\Gamma^{(k)}$ denotes the list of nodes in the k -th cluster and $\Gamma^{(k)}(j) = v_i$ means that node v_i corresponds to the j -th node in this cluster. With this sampling operator, the adjacency matrix for the k -th cluster can be formally defined as:

$$\mathbf{A}^{(k)} = (\mathbf{C}^{(k)})^\top \mathbf{A}^{(\text{ip})} \mathbf{C}^{(k)}.$$

Next, we discuss the process of generating graph structure and node features for the coarsened graph. To form the graph structure between the supernodes, only the connections across the clusters in the original graph are considered. To achieve the goal, we first generate the intra-cluster adjacency matrix for the input graph, which only consists of the edges within each cluster as:

$$\mathbf{A}_{int} = \sum_{k=1}^{N_{op}} \mathbf{C}^{(k)} \mathbf{A}^{(k)} (\mathbf{C}^{(k)})^\top.$$

Then, the inter-cluster adjacency matrix, which only consists of the edges across the clusters, can be represented as $\mathbf{A}_{ext} = \mathbf{A} - \mathbf{A}_{int}$. The adjacency matrix for the coarsened graph can be obtained as:

$$\mathbf{A}^{op} = \mathbf{S}^\top \mathbf{A}_{ext} \mathbf{S}.$$

Graph Fourier Transform is adopted to generate node features. Specifically, graph structure and node features of each subgraph (or cluster) are utilized to generate the node features for the corresponding supernode. Next, we take the k -th cluster as an illustrative example to demonstrate the process. Let $\mathbf{L}^{(k)}$ denote the Laplacian matrix for this subgraph and $\mathbf{u}_1^{(k)}, \dots, \mathbf{u}_{n^{(k)}}^{(k)}$ are its corresponding eigenvectors. The features of the nodes in this subgraph can be extracted from $\mathbf{F}^{(ip)}$ by using the sampling operator $\mathbf{C}^{(k)}$ as follows:

$$\mathbf{F}_{ip}^{(k)} = (\mathbf{C}^{(k)})^\top \mathbf{F}^{(ip)},$$

where $\mathbf{F}_{ip}^{(k)} \in \mathbb{R}^{N^{(k)} \times d_{ip}}$ is the input features for nodes in the k -th cluster.

Then, we apply Graph Fourier Transform to generate the graph Fourier coefficients for all channels of $\mathbf{F}_{ip}^{(k)}$ as:

$$\mathbf{f}_i^{(k)} = (\mathbf{u}_i^{(k)})^\top \mathbf{F}_{ip}^{(k)} \quad \text{for } i = 1, \dots, N^{(k)},$$

where $\mathbf{f}_i^{(k)} \in \mathbb{R}^{1 \times d_{ip}}$ consists of the i -th graph Fourier coefficients for all feature channels. The node features for the k -th supernode can be formed by concatenating these coefficients as:

$$\mathbf{f}^{(k)} = [\mathbf{f}_1^{(k)}, \dots, \mathbf{f}_{N^{(k)}}^{(k)}].$$

We usually only utilize the first few coefficients to generate features of supernodes for two reasons. First, different subgraphs may have varied numbers of nodes; hence, to ensure the same dimension of features, some of the coefficients need to be discarded. Second, the first few coefficients typically capture most of the important information as in reality, the majority of the graph signals are smooth.

5.5 Parameter Learning for Graph Neural Networks

In this section, we use node classification and graph classification as examples of downstream tasks to illustrate how to learn parameters of Graph Neural Networks. Note that we have formally defined the tasks of node classification and graph classification in Definition 2.42 and Definition 2.46, respectively.

5.5.1 Parameter Learning for Node Classification

As introduced in Definition 2.42, the node set of a graph \mathcal{V} can be divided to two disjoint sets, \mathcal{V}_l with labels and \mathcal{V}_u without labels. The goal of node classification is to learn a model based on the labeled nodes \mathcal{V}_l to predict the labels of the unlabeled nodes in \mathcal{V}_u . The GNN model usually takes the entire graph as input to generate node representations, which are then utilized to train a node classifier. Specifically, let $GNN_{\text{node}}(\cdot)$ denote a GNN model with several graph filtering layers stacked as introduced in Section 5.2.1. The $GNN_{\text{node}}(\cdot)$ function takes the graph structure and the node features as input and outputs the refined node features as follows:

$$\mathbf{F}^{(\text{out})} = GNN_{\text{node}}(\mathbf{A}, \mathbf{F}; \Theta_1), \quad (5.46)$$

where Θ_1 denotes the model parameters, $\mathbf{A} \in \mathbb{R}^{N \times N}$ is the adjacency matrix, $\mathbf{F} \in \mathbb{R}^{N \times d_{\text{in}}}$ is the input features of the original graph and $\mathbf{F}^{(\text{out})} \in \mathbb{R}^{N \times d_{\text{out}}}$ is the produced output features. Then, the output node features are utilized to perform node classification as:

$$\mathbf{Z} = \text{softmax}(\mathbf{F}^{(\text{out})} \Theta_2), \quad (5.47)$$

where $\mathbf{Z} \in \mathbb{R}^{N \times C}$ is the output logits for all nodes, $\Theta_2 \in \mathbb{R}^{d_{\text{out}} \times C}$ is the parameter matrix to transform the features \mathbf{F}_{out} into the dimension of the number of classes C . The i -th row of \mathbf{Z} indicates the predicted class distribution of node v_i and the predicted label is usually the one with the largest probability. The entire process can be summarized as:

$$\mathbf{Z} = f_{GNN}(\mathbf{A}, \mathbf{F}; \Theta), \quad (5.48)$$

where the function f_{GNN} consists of the processes in Eq. (5.46) and Eq. (5.47) and Θ includes the parameters Θ_1 and Θ_2 . The parameters Θ in Eq. (5.48) can be learned by minimizing the following objective:

$$\mathcal{L}_{\text{train}} = \sum_{v_i \in \mathcal{V}_l} \ell(f_{GNN}(\mathbf{A}, \mathbf{F}; \Theta)_i, y_i), \quad (5.49)$$

where $f_{GNN}(\mathbf{A}, \mathbf{F}; \Theta)_i$ denotes the i -th row of the output, i.e., the logits for node v_i , y_i is the associated label and $\ell(\cdot, \cdot)$ is a loss function such as cross-entropy loss.

5.5.2 Parameter Learning for Graph Classification

As introduced in Definition 2.46, in the task of graph classification, each graph is treated as a sample with an associated label. The training set can be denoted as $\mathcal{D} = \{\mathcal{G}_i, y_i\}$, where y_i is the corresponding label for graph \mathcal{G}_i . The task of graph classification is to train a model on the training set \mathcal{D} such that it can perform good predictions on unlabeled graphs. The graph neural network model is usually utilized as a feature encoder, which maps an input graph into a feature representation as follows:

$$\mathbf{f}_{\mathcal{G}} = GNN_{\text{graph}}(\mathcal{G}; \Theta_1), \quad (5.50)$$

where GNN_{graph} is the graph neural network model to learn graph-level representations. It often consists of graph filtering and graph pooling layers. $\mathbf{f}_{\mathcal{G}} \in \mathbb{R}^{1 \times d_{\text{out}}}$ is the produced graph-level representation. This graph-level representation is then utilized to perform the graph classification as:

$$\mathbf{z}_{\mathcal{G}} = \text{softmax}(\mathbf{f}_{\mathcal{G}} \Theta_2), \quad (5.51)$$

where $\Theta_2 \in \mathbb{R}^{d_{\text{out}} \times C}$ transforms the graph representation to the dimension of the number of classes C and $\mathbf{z}_{\mathcal{G}} \in \mathbb{R}^{1 \times C}$ denotes the predicted logits for the input graph \mathcal{G} . The graph \mathcal{G} is typically assigned to the label with the largest logit. The entire process of graph classification can be summarized as follows:

$$\mathbf{z}_{\mathcal{G}} = f_{GNN}(\mathcal{G}; \Theta), \quad (5.52)$$

where f_{GNN} is the function includes Eq. (5.50) and Eq. (5.51) and Θ includes parameters Θ_1 and Θ_2 . The parameter Θ can be learned by minimizing the following objective:

$$\mathcal{L}_{\text{train}} = \sum_{\mathcal{G}_i \in \mathcal{D}} \ell(f_{GNN}(\mathcal{G}_i, \Theta), y_i),$$

where y_i is the associated label of \mathcal{G}_i and $\ell(\cdot, \cdot)$ is a loss function.

5.6 Conclusion

In this chapter, we introduce the graph neural network (GNN) frameworks for both node-focused and graph-focused tasks. Specifically, we introduce two

major components: 1) the graph filtering layer, which refines the node features; and 2) the graph pooling layer, which aims to coarsen the graph and finally generate the graph-level representation. We categorize graph filters as spectral-based and spatial-based filters, then review representative algorithms for each category and discuss the connections between these two categories. We group graph pooling as flat graph pooling and hierarchical graph pooling and introduce representative methods for each group. Finally, we present how to learn GNN parameters via downstream tasks including node classification and graph classification.

5.7 Further Reading

Besides from the graph neural network models introduced in this chapter, there are also some other attempts to learn graph-level representations for graph classification utilizing neural networks (Yanardag and Vishwanathan, 2015; Niepert et al., 2016; Lee et al., 2018). In addition to representative graph filtering and pooling operations introduced above, there are more graph filtering and pooling methods (Li et al., 2018c; Gao et al., 2018a; Zhang et al., 2018a; Liu et al., 2019b; Velickovic et al., 2019; Morris et al., 2019; Gao et al., 2020; Yuan and Ji, 2019). Meanwhile, several surveys introduce and summarize the graph neural network models from different perspectives (Zhou et al., 2018a; Wu et al., 2020; Zhang et al., 2018c). As graph neural network research has gained increasing attention, multiple handy libraries have been designed to ease the development of graph neural network models. These packages include *Pytorch Geometric (PyG)* (Fey and Lenssen, 2019), which is developed upon PyTorch; and *Deep Graph Library (DGL)* (Wang et al., 2019e), which has various deep learning frameworks including Pytorch and Tensorflow as its backend.

6

Robust Graph Neural Networks

6.1 Introduction

As the generalizations of traditional DNNs to graphs, GNNs inherit both advantages and disadvantages of traditional DNNs. Like traditional DNNs, GNNs have been shown to be effective in many graph-related tasks such as node-focused and graph-focused tasks. Traditional DNNs have been demonstrated to be vulnerable to dedicated designed adversarial attacks (Goodfellow et al., 2014b; Xu et al., 2019b). Under adversarial attacks, the victimized samples are perturbed in such a way that they are not easily noticeable, but they can lead to wrong results. It is increasingly evident that GNNs also inherit this drawback. The adversary can generate graph adversarial perturbations by manipulating the graph structure or node features to fool the GNN models. This limitation of GNNs has arisen immense concerns on adopting them in safety-critical applications such as financial systems and risk management. For example, in a credit scoring system, fraudsters can fake connections with several high-credit customers to evade the fraudster detection models; and spammers can easily create fake followers to increase the chance of fake news being recommended and spread. Therefore, we have witnessed more and more research attention to graph adversarial attacks and their countermeasures. In this chapter, we first introduce concepts and definitions of graph adversarial attacks and detail some representative adversarial attack methods on graphs. Then, we discuss representative defense techniques against these adversarial attacks.

6.2 Graph Adversarial Attacks

In graph-structured data, the adversarial attacks are usually conducted by modifying the graph structure and/or node features in an unnoticeable way such that

the prediction performance can be impaired. Specifically, we denote a graph adversarial attacker as \mathcal{T} . Given a targeted model $f_{GNN}(\cdot; \Theta)$ (either for node classification or for graph classification), the attacker \mathcal{T} tries to modify a given graph \mathcal{G} and generate an attacked graph \mathcal{G}' as:

$$\mathcal{G}' = \mathcal{T}(\mathcal{G}; f_{GNN}(\cdot; \Theta)) = \mathcal{T}(\{\mathbf{A}, \mathbf{F}\}; f_{GNN}(\cdot; \Theta)),$$

where $\mathcal{G} = \{\mathbf{A}, \mathbf{F}\}$ is the input graph with \mathbf{A} and \mathbf{F} denoting its adjacency matrix and feature matrix and $\mathcal{G}' = \{\mathbf{A}', \mathbf{F}'\}$ is the produced attacked graph. Note that in this chapter, without specific mention, both the graph structure and the input features are assumed to be discrete, i.e. $\mathbf{A} \in \{0, 1\}^{N \times N}$ and $\mathbf{F} \in \{0, 1\}^{N \times d}$, respectively. The attacker is usually constraint to make unnoticeable modifications on the input graph, which can be represented as:

$$\mathcal{G}' \in \Phi(\mathcal{G}),$$

where $\Phi(\mathcal{G})$ denotes a constraint space that consists of graphs that are “close” to the graph \mathcal{G} . There are various ways to define the space $\Phi(\mathcal{G})$, which we will introduce when describing the attack methods. A typical and most commonly adopted constraint space is defined as:

$$\Phi(\mathcal{G}) = \{\mathcal{G}' = \{\mathbf{A}', \mathbf{F}'\}; \|\mathbf{A}' - \mathbf{A}\|_0 + \|\mathbf{F}' - \mathbf{F}\|_0 \leq \Delta\}, \quad (6.1)$$

which means that the constraint space $\Phi(\mathcal{G})$ contains all the graphs that are within a given perturbation budget Δ away from the input graph \mathcal{G} . The goal of the attacker \mathcal{T} is that the prediction results on the attacked graph \mathcal{G}' are different from the original input graph. For the node classification task, we focus on the prediction performance of a subset of nodes, which is called the victimized nodes and denoted as $\mathcal{V}_t \subseteq \mathcal{V}_u$ where \mathcal{V}_u is the set of unlabeled nodes in \mathcal{G} . While for the graph classification task, we concentrate on the prediction performance on a test set of graphs.

6.2.1 Taxonomy of Graph Adversarial Attacks

We can categorize graph adversarial attack algorithms differently according to the capacity, available resources, goals, and accessible knowledge of attackers.

Attackers' Capacity

Adversaries can perform attacks during both the model training and the model test stages. We can roughly divide attacks to evasion and poisoning attacks based on the attacker's capacity to insert adversarial perturbations:

- **Evasion Attack.** Attacking is conducted on the trained GNN model or in the test stage. Under the evasion attack setting, the adversaries cannot change the model parameters or structures.
- **Poisoning Attack.** Attacking happens before the GNN model is trained. Thus, the attackers can insert “poisons” into the training data such that the GNN models trained on this data have malfunctions.

Perturbation Type

In addition to node features, graph-structured data provides rich structural information. Thus, the attacker can perturb graph-structured data from different perspectives such as modifying node features, adding/deleting edges, and adding fake nodes:

- **Modifying Node Features.** Attackers can slightly modify the node features while keeping the graph structure.
- **Adding or deleting edges:** Attackers can add or delete edges.
- **Injecting Nodes.** Attackers can inject fake nodes to the graph, and link them with some benign nodes in the graph.

Attackers’ Goal

According to the attackers’ goal, we can divide the attacks into two groups:

- **Targeted Attack.** Given a small set of test nodes (or targeted nodes), the attackers target on making the model misclassify these test samples. Targeted attacks can be further grouped into (1) direct attacks where the attacker directly perturbs the targeted nodes and (2) influencer attacks where the attacker can only manipulate other nodes to influence the targeted nodes.
- **Untargeted Attack.** The attacker aims to perturb the graph to reduce the model’s overall performance.

Attackers’ Knowledge

The attacks can be categorized into three classes according to the level of accessible knowledge towards the GNN model $f_{GNN}(\cdot; \Theta)$ as follows:

- **White-box attack.** In this setting, the attackers are allowed to access full information of the attacked model $f_{GNN}(\cdot; \Theta)$ (or the victim model) such as its architecture, parameters, and training data.
- **Gray-box attack.** In this setting, the attackers cannot access the architecture and the parameters of the victim model, but they can access the data utilized to train the model.

- **Black-box attack.** In this setting, the attackers can access to minimal information of the victim model. The attackers cannot access the architecture, model parameters, and the training data. The attackers are only allowed to query from the victim model to obtain the predictions.

In the following sections, we present some representative attack methods from each category based on attackers' knowledge, i.e., white-box, gray-box, and black-box attacks.

6.2.2 White-box Attack

In the white-box attack setting, the attacker is allowed to access full information of the victim model. In reality, this setting is not practical since complete information is often unavailable. However, it can still provide some information about the model's robustness against adversarial attacks. Most existing methods in this category utilize the gradient information to guide the attacker. There are two main ways to use the gradient information – 1) formulating the attack problem as an optimization problem that is addressed by the gradient-based method; and 2) using the gradient information to measure the effectiveness of modifying graph structure and features. Next, we present representative white-box attacks from these two ways.

PGD Topology Attack

In (Xu et al., 2019c), the attacker is only allowed to modify the graph structures but not the node features. The goal of the attacker is to reduce the node classification performance on a set of victimized nodes \mathcal{V}_t . A symmetric Boolean matrix $\mathbf{S} \in \{0, 1\}^{N \times N}$ is introduced to encode the modification made by the attacker \mathcal{T} . Specifically, the edge between node v_i and node v_j is modified (added or removed) only when $\mathbf{S}_{i,j} = 1$, otherwise the edge is not modified. Given the adjacency matrix of a graph \mathcal{G} , its supplement can be represented as $\bar{\mathbf{A}} = \mathbf{1}\mathbf{1}^\top - \mathbf{I} - \mathbf{A}$, where $\mathbf{1} \in \mathbb{R}^N$ is a vector with all elements as 1. Applying the attacker \mathcal{T} on the graph \mathcal{G} can be represented as:

$$\mathbf{A}' = \mathcal{T}(\mathbf{A}) = \mathbf{A} + (\bar{\mathbf{A}} - \mathbf{A}) \odot \mathbf{S}, \quad (6.2)$$

where \odot denotes the Hadamand product. The matrix $\bar{\mathbf{A}} - \mathbf{A}$ indicates whether an edge exists in the original graph or not. Specifically, when $(\bar{\mathbf{A}} - \mathbf{A})_{i,j} = 1$, there is no edge existing between node v_i and node v_j , thus the edge can be added by the attacker. When $(\bar{\mathbf{A}} - \mathbf{A})_{i,j} = -1$, there is an edge between nodes v_i and v_j , and it can be removed by the attacker.

The goal of the attacker \mathcal{T} is to find \mathbf{S} that can lead to bad prediction performance. For a certain node v_i , given its true label y_i , the prediction performance

can be measured by the following CW-type loss adapted from Carlini-Wagner (CW) attacks in the image domain (Carlini and Wagner, 2017):

$$\ell(f_{GNN}(\mathcal{G}'; \Theta)_i, y_i) = \max \left\{ \mathbf{Z}'_{i,y_i} - \max_{c \neq y_i} \mathbf{Z}'_{i,c}, -\kappa \right\}, \quad (6.3)$$

where $\mathcal{G}' = \{\mathbf{A}', \mathbf{F}\}$ is the attacked graph, $f_{GNN}(\mathcal{G}'; \Theta)_i$ is utilized to denote the i -th row of $f_{GNN}(\mathcal{G}'; \Theta)$, $\mathbf{Z}' = f_{GNN}(\mathcal{G}'; \Theta)$ is the logits calculated with Eq. (5.48) on the attacked graph \mathcal{G}' . Note that we use the class labels y_i and c as the indices to retrieve the predicted probabilities of the corresponding classes. Specifically, \mathbf{Z}'_{i,y_i} is the y_i -th element of the i -th row of \mathbf{Z}' , which indicates the probability of node v_i predicted as class y_i . The term $\mathbf{Z}'_{i,y_i} - \max_{c \neq y_i} \mathbf{Z}'_{i,c}$ in Eq. (6.3) measures the difference of the predicted probability between the true label y_i and the largest logit among all other classes. It is smaller than 0 when the prediction is wrong. Hence, for the goal of the attacker, we include a penalty when its value is larger than 0. Furthermore, in Eq. (6.3), $\kappa > 0$ is included as a confidence level of making wrong predictions. It means that a penalty is given when the difference between the logit of the true label y_i and the largest logit among all other classes is larger than $-\kappa$. A larger κ means that the prediction needs to be strongly wrong to avoid a penalty.

The attacker \mathcal{T} is to find \mathbf{S} in Eq. (6.2) such that it can minimize the CW-loss in Eq. (6.3) for all the nodes in the victimized node set \mathcal{V}_t given a limited budget. Specifically, this can be represented as the following optimization problem:

$$\begin{aligned} \min_{\mathbf{s}} \mathcal{L}(\mathbf{s}) &= \sum_{v_i \in \mathcal{V}_t} \ell(f_{GNN}(\mathcal{G}'; \Theta)_i, y_i) \\ \text{subject to} \quad &\|\mathbf{s}\|_0 \leq \Delta, \mathbf{s} \in \{0, 1\}^{N(N-1)/2}, \end{aligned} \quad (6.4)$$

where Δ is the budget to modify the graph and $\mathbf{s} \in \{0, 1\}^{N(N-1)/2}$ is the vectorized \mathbf{S} consisting of its independent perturbation variables. Note that \mathbf{S} contains $N(N-1)/2$ independent perturbation variables, since \mathbf{S} is a symmetric matrix with diagonal elements fixed to 0. The constraint term can be regarded as limiting the attacked graph \mathcal{G}' in the space $\Phi(\mathcal{G})$ defined by the constraint on \mathbf{s} . The problem in Eq. (6.4) is a combinatorial optimization problem. For the ease of optimization, the constraint $\mathbf{s} \in \{0, 1\}^{N(N-1)/2}$ is relaxed to its convex hull $\mathbf{s} \in [0, 1]^{N(N-1)/2}$. Specifically, we denote the constraint space as $\mathcal{S} = \{\mathbf{s}; \|\mathbf{s}\|_0 \leq \Delta, \mathbf{s} \in [0, 1]^{N(N-1)/2}\}$. Then the problem in Eq. (6.4) is now transformed to a continuous optimization problem. It can be solved by the projected gradient descent (PGD) method as:

$$\mathbf{s}^{(t)} = \mathcal{P}_{\mathcal{S}}[\mathbf{s}^{(t-1)} - \eta_t \nabla \mathcal{L}(\mathbf{s}^{(t-1)})],$$

where $\mathcal{P}_{\mathcal{S}}(\mathbf{x}) := \arg \min_{\mathbf{s} \in \mathcal{S}} \|\mathbf{s} - \mathbf{x}\|_2^2$ is the projection operator to project \mathbf{x} into the continuous space \mathcal{S} . After obtaining the continuous \mathbf{s} using the PGD method, the discrete \mathbf{s} can be randomly sampled from it. Specifically, each element in the obtained \mathbf{s} is regarded as the probability to sample 1 for the corresponding element of the discrete \mathbf{s} .

Integrated Gradient Guided Attack

The gradient information is utilized as scores to guide the attack in (Wu et al., 2019). The attacker is allowed to modify both the graph structure and the features. The attacker's goal is to impair the node classification performance of a single victimized node v_i . When modifying the structure, the attacker \mathcal{T} is allowed to remove/add edges. The node features are assumed to be discrete features such as word occurrence or categorical features with binary values. Hence, the modification on both the graph structure and node features is limited to changing from either 0 to 1 or 1 to 0. This process can be guided by the gradient information of the objective function (Wu et al., 2019).

Inspired by Fast Gradient Sign Method (FGSM) (Goodfellow et al., 2014b), one way to find the adversarial attack is to maximize the loss function used to train the neural network with respect to the input sample. For the victimized node v_i with label y_i , this loss can be denoted as:

$$\mathcal{L}_i = \ell(f_{GNN}(\mathbf{A}, \mathbf{F}; \Theta)_i, y_i).$$

In FSGM, one-step gradient ascent method is utilized to maximize the loss and consequently find the adversarial sample. However, in the graph setting, both the graph structure and node features are discrete, which cannot be derived by gradient-based methods. Instead, the gradient information corresponding to each element in \mathbf{A} and \mathbf{F} is used to measure how their changes affect the value of loss function. Thus, it can be used to guide the attacker to perform the adversarial perturbation. However, as the attacker is only allowed to perform modification from either 0 to 1 or 1 to 0, the gradient information may not help too much for the following reason – given that the graph neural network model is non-linear, the gradient on a single point cannot reflect the effect of a large change such as from 0 to 1 or from 1 to 0. Hence, inspired by the integrated gradients (Sundararajan et al., 2017), discrete integrated gradients are utilized to design the scores, which are called as the integrated gradient scores (IG-scores). Specifically, the IG-score discretely accumulates the gradient in-

formation of changing from 0 to 1 or from 1 to 0 as:

$$IG_{\mathbf{H}}(i, j) = \frac{\mathbf{H}_{i,j}}{m} \sum_{k=1}^m \frac{\partial \mathcal{L}_i(\frac{k}{m}(\mathbf{H}_{i,j} - 0))}{\partial \mathbf{H}_{i,j}}; \quad 1 \rightarrow 0, \text{ when } \mathbf{H}_{i,j} = 1;$$

$$IG_{\mathbf{H}}(i, j) = \frac{1 - \mathbf{H}_{i,j}}{m} \sum_{k=1}^m \frac{\partial \mathcal{L}_i(0 + \frac{k}{m}(1 - \mathbf{H}_{i,j}))}{\partial \mathbf{H}_{i,j}}; \quad 0 \rightarrow 1, \text{ when } \mathbf{H}_{i,j} = 0;$$

where \mathbf{H} could be either \mathbf{A} or \mathbf{F} , and m is a hyperparameter indicating the number of discrete steps. We denote the IG -scores for the candidate changes in \mathbf{A} and \mathbf{F} as $IG_{\mathbf{A}}$ and $IG_{\mathbf{F}}$ respectively, which measure how the corresponding change in each element of \mathbf{A} and \mathbf{F} affects the loss \mathcal{L}_i . Then, the attacker \mathcal{T} can make the modification by selecting the action with the largest IG -score among $IG_{\mathbf{A}}$ and $IG_{\mathbf{F}}$. The attacker repeats this process as long as the resulting graph $\mathcal{G}' \in \Phi(\mathcal{G})$, where $\Phi(\mathcal{G})$ is defined as in Eq. (6.1).

6.2.3 Gray-box Attack

In the gray-box attack setting, the attacker is not allowed to access the architecture and parameters of the victim model, but can access the data utilized to train the model. Hence, instead of directly attacking the given model, the gray-box attacks often first train a surrogate model with the provided training data and then attack the surrogate model on a given graph. They assume that these attacks on the graph via the surrogate model can also damage the performance of the victim model. In this section, we introduce representative gray-box attack methods.

Nettack

The Nettack model (Zügner et al., 2018) targets on generating adversarial graphs for the node classification task. A single node v_i is selected as the victim node to be attacked and the goal is to modify the structure and/or the features of this node or its nearby nodes to change the prediction on this victim node. Let us denote the label of the victim node v_i as y_i , where y_i could be either the ground truth or the label predicted by the victim model $f_{GNN}(\mathbf{A}, \mathbf{F}; \Theta)$ on the original clean graph \mathcal{G} . The goal of the attacker is to modify the graph \mathcal{G} to $\mathcal{G}' = \{\mathbf{A}', \mathbf{F}'\}$ such that the model trained on the attacked graph \mathcal{G}' classifies the node v_i as a new class c . In general, the attacking problem can be described as the following optimization problem:

$$\arg \max_{\mathcal{G}' \in \Phi(\mathcal{G})} \left(\max_{c \neq y_i} \ln \mathbf{Z}'_{i,c} - \ln \mathbf{Z}'_{i,y_i} \right), \quad (6.5)$$

where $\mathbf{Z}' = f_{GNN}(\mathbf{A}', \mathbf{F}'; \Theta')$ with the parameters Θ' learned by minimizing Eq. (5.49) on the attacked graph \mathcal{G}' . Here, the space $\Phi(\mathcal{G})$ is defined based on the limited budget constraint as Eq. (6.1) and two more constraints on the perturbations. These two constraints are: 1) the degree distribution of the attacked graph should be close to that of the original graph; and 2) the distribution of the feature occurrences (for the discrete features) of the attacked graph should be close to that of the original graph. Solving the problem in Eq. (6.5) directly is very challenging as the problem involves two dependent stages. The discrete structure of the graph data further increases the difficulty. To address these difficulties, we first train a *surrogate model* on the original clean graph data \mathcal{G} and then generate the adversarial graph by attacking the surrogate model. The adversarial graph is treated as the attacked graph. When attacking graph neural network model built upon GCN-Filters (see Section 5.3.2 for details on GCN-Filter) for node classification, the following surrogate model with 2 GCN-Filters and no activation layers is adopted:

$$\mathbf{Z}^{sur} = \text{softmax}(\tilde{\mathbf{A}}\tilde{\mathbf{A}}\mathbf{F}\Theta_1\Theta_2) = \text{softmax}(\tilde{\mathbf{A}}^2\mathbf{F}\Theta), \quad (6.6)$$

where the parameters Θ_1 and Θ_2 are absorbed in Θ . The parameters Θ are learned from the original clean graph \mathcal{G} with the provided training data. To perform the adversarial attack based on the surrogate model, as in Eq. (6.5), we aim to find these attacks that maximize the difference, i.e., $\max_{c \neq y_i} \ln \mathbf{Z}_{i,c}^{sur} - \ln \mathbf{Z}_{i,y_i}^{sur}$. To further simplify the problem, the instance independent softmax normalization is removed, which results in the following surrogate loss:

$$\mathcal{L}_{sur}(\mathbf{A}, \mathbf{F}; \Theta, v_i) = \max_{c \neq y_i} \left([\tilde{\mathbf{A}}^2\mathbf{F}\Theta]_{i,c} - [\tilde{\mathbf{A}}^2\mathbf{F}\Theta]_{i,y_i} \right).$$

Correspondingly the optimization problem can be expressed as:

$$\text{argmax}_{\mathcal{G}' \in \Phi(\mathcal{G})} \mathcal{L}_{sur}(\mathbf{A}', \mathbf{F}'; \Theta, v_i). \quad (6.7)$$

While being much simpler, this problem is still intractable to be solved exactly. Hence, a greedy algorithm is adopted, where we measure the scores of all the possible steps (adding/deleting edges and flip features) as follows:

$$\begin{aligned} s_{str}(e; \mathcal{G}^{(t)}, v_i) &:= \mathcal{L}_{sur}(\mathbf{A}^{(t+1)}, \mathbf{F}^{(t)}; \Theta, v_i) \\ s_{feat}(f; \mathcal{G}^{(t)}, v_i) &:= \mathcal{L}_{sur}(\mathbf{A}^{(t)}, \mathbf{F}^{(t+1)}; \Theta, v_i) \end{aligned}$$

where $\mathcal{G}^{(t)} = \{\mathbf{A}^{(t)}, \mathbf{F}^{(t)}\}$ is the intermediate result of the algorithm at the step t , $\mathbf{A}^{(t+1)}$ is one step change from $\mathbf{A}^{(t)}$ by adding/deleting the edge e and $\mathbf{F}^{(t+1)}$ is one step change away from $\mathbf{F}^{(t)}$ by flipping the feature f . The score $s_{str}(e; \mathcal{G}^{(t)}, v_i)$ measures the impact of changing the edge e on the loss function, while $s_{feat}(f; \mathcal{G}^{(t)}, v_i)$ indicates how changing the feature f affects the loss function. In each step, the

greedy algorithm chooses the edge or the feature with the largest score to perform the corresponding modification, i.e. (adding/deleting edges or flipping features). The process is repeated as long as the resulting graph is still in the space of $\Phi(\mathcal{G})$.

Metattack

The Metattack method in (Zügner and Günnemann, 2019) tries to modify the graph to reduce the overall node classification performance on the test set, i.e., the victim node set $\mathcal{V}_t = \mathcal{V}_u$. The attacker in Metattack is limited to modify the graph structure. The constraint space $\Phi(\mathcal{G})$ is adopted from Nettack where the limited budget constraint and the degree preserving constraint are used to define the constraint space. The metattack is a poisoning attack. Thus, after generating the adversarial attacked graph, we need to retrain the victim model on the attacked graph. The goal of the attacker is to find such an adversarial attacked graph that the performance of the retrained victim GNN model is impaired. Hence, the attacker can be mathematically formulated as a bi-level optimization problem as:

$$\min_{\mathcal{G}' \in \Phi(\mathcal{G})} \mathcal{L}_{atk}(f_{GNN}(\mathcal{G}'; \Theta^*)) \quad s.t. \quad \Theta^* = \arg \min_{\Theta} \mathcal{L}_{tr}(f_{GNN}(\mathcal{G}'; \Theta)), \quad (6.8)$$

where $f_{GNN}()$ is the victim model, and \mathcal{L}_{tr} denotes the loss function used to train the model as defined in Eq. (5.49) over the training set \mathcal{V}_l . The loss function \mathcal{L}_{atk} is to be optimized to generate the adversarial attack. In particular, the lower-level optimization problem with respect to Θ is to find the best model parameters Θ^* given the attacked graph \mathcal{G}' , while the higher-level optimization problem is to minimize \mathcal{L}_{atk} to generate the attacked graph \mathcal{G}' . Since the goal of the attacker is to impair the performance on the unlabelled nodes, ideally, \mathcal{L}_{atk} should be defined based on \mathcal{V}_u . However, we cannot directly calculate the loss based on \mathcal{V}_u without the labels. Instead, one approach, which is based on the argument that the model cannot generalize well if it has high training error, is to define \mathcal{L}_{atk} as the negative of the \mathcal{L}_{tr} , i.e., $\mathcal{L}_{atk} = -\mathcal{L}_{tr}$. Another way to formulate \mathcal{L}_{atk} is to first predict labels for the unlabeled nodes using a well trained surrogate model on the original graph \mathcal{G} and then use the predictions as the “labels”. More specifically, let C'_u denote the “labels” of unlabeled nodes \mathcal{V}_u predicted by the surrogate model. The loss function $\mathcal{L}_{self} = \mathcal{L}(f_{GNN}(\mathcal{G}'; \Theta^*), C'_u)$ measures the disagreement between the “labels” C'_u and the predictions from $f_{GNN}(\mathcal{G}'; \Theta^*)$ as in Eq. (5.49) over the set \mathcal{V}_u . The second option of \mathcal{L}_{atk} can be defined as $\mathcal{L}_{atk} = -\mathcal{L}_{self}$. Finally, the \mathcal{L}_{atk} is defined as a combination of the two loss functions as:

$$\mathcal{L}_{atk} = -\mathcal{L}_{tr} - \beta \cdot \mathcal{L}_{self},$$

where β is a parameter controlling the importance of \mathcal{L}_{self} .

To solve the bi-level optimization problem in Eq. (6.8), the meta-gradients, which have traditionally been used in meta-learning, are adopted. Meta-gradients can be viewed as the gradients with respect to the hyper-parameters. In this specific problem, the graph structure (or the adjacency matrix \mathbf{A}) is treated as the hyperparameters. The goal is to find the “optimal” structure such that the loss function \mathcal{L}_{atk} is minimized. The meta-gradient with respect to the graph \mathcal{G} can be defined as:

$$\nabla_{\mathcal{G}}^{meta} := \nabla_{\mathcal{G}} \mathcal{L}_{atk}(f_{GNN}(\mathcal{G}; \Theta^*)) \quad s.t. \quad \Theta^* = \arg \min_{\Theta} \mathcal{L}_{tr}(f_{GNN}(\mathcal{G}; \Theta)). \quad (6.9)$$

Note that the meta-gradient is related to the parameter Θ^* as Θ^* is a function of the graph \mathcal{G} according to the second part of Eq. (6.9). The meta-gradient indicates how a small change in the graph \mathcal{G} affects the attacker loss \mathcal{L}_{atk} , which can guide us how to modify the graph.

The inner problem of Eq. (6.8) (the second part of Eq. (6.9)) typically does not have an analytic solution. Instead, a differentiable optimization procedure such as vanilla gradient descent or stochastic gradient descent (SGD) is adopted to obtain Θ^* . This optimization procedure can be represented as $\Theta^* = \text{opt}_{\Theta} \mathcal{L}_{tr}(f_{GNN}(\mathcal{G}; \Theta))$. Thus, the meta-gradient can be reformulated as:

$$\nabla_{\mathcal{G}}^{meta} := \nabla_{\mathcal{G}} \mathcal{L}_{atk}(f_{GNN}(\mathcal{G}; \Theta^*)) \quad s.t. \quad \Theta^* = \text{opt}_{\Theta} \mathcal{L}_{tr}(f_{GNN}(\mathcal{G}; \Theta)). \quad (6.10)$$

As an illustration, the opt_{Θ} with vanilla gradient descent can be formalized as:

$$\Theta_{t+1} = \Theta_t - \eta \cdot \nabla_{\Theta_t} \mathcal{L}_{tr}(f_{GNN}(\mathcal{G}; \Theta_t)) \quad \text{for } t = 0, \dots, T - 1,$$

where η is the learning rate, Θ_0 denotes the initialization of the parameters, T is the total number of steps of the gradient descent procedure and $\Theta^* = \Theta_T$. The meta-gradient can now be expressed by unrolling the training procedure as follows:

$$\begin{aligned} \nabla_{\mathcal{G}}^{meta} &= \nabla_{\mathcal{G}} \mathcal{L}_{atk}(f_{GNN}(\mathcal{G}; \Theta_T)) \\ &= \nabla_{f_{GNN}} \mathcal{L}_{atk}(f_{GNN}(\mathcal{G}; \Theta_T)) \cdot [\nabla_{\mathcal{G}} f_{GNN}(\mathcal{G}; \Theta_T) + \nabla_{\Theta_T} f_{GNN}(\mathcal{G}; \Theta_T) \cdot \nabla_{\mathcal{G}} \Theta_T], \end{aligned}$$

where

$$\nabla_{\mathcal{G}} \Theta_{t+1} = \nabla_{\mathcal{G}} \Theta_t - \eta \nabla_{\mathcal{G}} \nabla_{\Theta_t} \mathcal{L}_{tr}(f_{GNN}(\mathcal{G}; \Theta_t)).$$

Note that the parameter Θ_t is dependent on the graph \mathcal{G} ; thus, the derivative with respect to the graph \mathcal{G} has to chain back all the way to the initial parameter Θ_0 . After obtaining the meta-gradient, we can now use it to update the graph

as:

$$\mathcal{G}^{(k+1)} = \mathcal{G}^{(k)} - \gamma \nabla_{\mathcal{G}^{(k)}} \mathcal{L}_{atk}(f_{GNN}(\mathcal{G}; \Theta_T)). \quad (6.11)$$

The gradients are dense; thus, the operation in Eq. (6.11) results in a dense graph, which is not desired. Furthermore, as the structure and the parameters of the model are unknown in the gray-box setting, the meta-gradients cannot be obtained. To solve these two issues, a greedy algorithm utilizing the meta-gradient calculated on a surrogate model as the guidance to choose the action is further proposed in (Zügner and Günnemann, 2019). We next introduce the meta-gradient based greedy algorithm. The same surrogate model as Eq. (6.6) is utilized to replace $f_{GNN}(\mathcal{G}; \Theta)$ in Eq. (6.8). A score to measure how a small change in the i, j -th element of the adjacency matrix \mathbf{A} affects the loss function \mathcal{L}_{atk} is defined by using the meta-gradient as:

$$s(i, j) = \nabla_{\mathbf{A}_{i,j}}^{meta} \cdot (-2 \cdot \mathbf{A}_{i,j} + 1),$$

where the term $(-2 \cdot \mathbf{A}_{i,j} + 1)$ is used to flip the sign of the meta-gradients when $\mathbf{A}_{i,j} = 1$, i.e., the edge between nodes v_i and v_j exists and can only be removed. After calculating the score for each possible action based on the meta-gradients, the attacker takes the action with the largest score. For a chosen node pair (v_i, v_j) , the attacker adds an edge between them if $\mathbf{A}_{i,j} = 0$ while removing the edge between them if $\mathbf{A}_{i,j} = 1$. The process is repeated as long as the resulting graph is in the space $\Phi(\mathcal{G})$.

6.2.4 Black-box Attack

In the black-box attack setting, the victim model's information is not accessible to the attacker. The attacker can only query the prediction results from the victim model. Most methods in this category adopt reinforcement learning to learn the strategies of the attacker. They treat the victim model as a black-box query machine and use the query results to design the reward for reinforcement learning.

RL-S2V

The RL-S2V method is a black-box attack model using reinforcement learning (Dai et al., 2018). In this setting, a target classifier $f_{GNN}(\mathcal{G}; \Theta)$ is given with the parameters Θ learned and fixed. The attacker is asked to modify the graph such that the classification performance is impaired. The RL-S2V attacker can be used to attack both the node classification task and the graph classification task. The RL-S2V attacker only modifies the graph structure and leaves the graph features untouched. To modify the graph structure, the RL-S2V attacker

is allowed to add or delete edges from the original graph \mathcal{G} . The constraint space for RL-S2V can be defined as:

$$\Phi(\mathcal{G}) = \{\mathcal{G}'; |(\mathcal{E} - \mathcal{E}') \cup (\mathcal{E}' - \mathcal{E})| \leq \Delta\} \quad (6.12)$$

with $\mathcal{E}' \subset \mathcal{N}(\mathcal{G}, b)$,

where \mathcal{E} and \mathcal{E}' denote the edge sets of the original graph \mathcal{G} and the attacked graph \mathcal{G}' , respectively. Δ is the budget limit to remove and add edges. Furthermore, $\mathcal{N}(\mathcal{G}, b)$ is defined as:

$$\mathcal{N}(\mathcal{G}, b) = \{(v_i, v_j) : v_i, v_j \in \mathcal{V}, \text{dis}^{(\mathcal{G})}(v_i, v_j) \leq b\}.$$

where $\text{dis}^{(\mathcal{G})}(v_i, v_j)$ denotes the shortest path distance between node v_i and node v_j in the original graph \mathcal{G} . $\mathcal{N}(\mathcal{G}, b)$ includes all edges connecting nodes at most b -hop away in the original graph. The attacking procedure of RL-S2V is modeled as a Finite Markov Decision Process (MDP), which can be defined as follows:

- **Action:** As mentioned before, there are two types of actions: adding and deleting edges. Furthermore, only those actions that lead to a graph in the constraint space $\Phi(\mathcal{G})$ are considered as valid actions.
- **State:** The state s_t at the time step t is the intermediate graph \mathcal{G}_t , which is obtained by modifying the intermediate graph \mathcal{G}_{t-1} by a single action.
- **Reward:** The purpose of the attacker is to modify the graph such that the targeted classifier would be fooled. A reward is only granted when the attacking process (MDP) has been terminated. More specifically, a positive reward $r(s_t, a_t) = 1$ is granted if the targeted model makes a different prediction from the original one; otherwise, a negative reward of $r(s_t, a_t) = -1$ is granted. For all the intermediate steps, the reward is set to $r(s_t, a_t) = 0$.
- **Terminal:** The MDP has a total budget of Δ to perform the actions. The MDP is terminated once the agent reaches the budget Δ , i.e., the attacker has modified Δ edges.

Deep Q-learning is adopted to learn the MDP (Dai et al., 2018). Specifically, Q-learning (Watkins and Dayan, 1992) is to fit the following Bellman optimal equation:

$$Q^*(s_t, a_t) = r(s_t, a_t) + \gamma \max_{a'} Q^*(s_{t+1}, a'),$$

In particular, $Q^*(\cdot)$ is a parametrized function to approximate the optimal expected future value (or the expected total reward of all future steps) given a state-action pair and γ is the discount factor. Once the $Q^*(\cdot)$ function is learned

during training, it implicitly indicates a greedy policy:

$$\pi(a_t|s_t; Q^*) = \arg \max_{a_t} Q^*(s_t, a_t).$$

With the above policy, at state s_t , the action a_t which can maximize the Q^* () function is chosen. The Q^* () function can be parameterized with GNN models for learning the graph-level representation, as the state s_t is a graph.

Note that an action a_t involves two nodes, which means the search space for an action is $O(N^2)$. This might be too expensive for large graphs. Hence, in (Dai et al., 2018), a decomposition of the action a_t has been proposed as:

$$a_t = (a_t^{(1)}, a_t^{(2)}),$$

where $a_t^{(1)}$ is the sub-action to choose the first node and $a_t^{(2)}$ is the sub-action to choose the second node. Hierarchical Q^* () function is designed to learn the policies for the decomposed actions.

ReWatt

ReWatt (Ma et al., 2020a) is a black-box attacker, which targets on the graph classification task. In this setting, the graph classification model $f_{GNN}(\mathcal{G}; \Theta)$ as defined in Section 5.5.2 is given and fixed. The attacker cannot access any information about the model except querying prediction results for graph samples. It is argued in (Ma et al., 2020a) that the operations such as deleting/adding edges are not unnoticeable enough. Hence, a less noticeable operation, i.e., the rewiring operation, is proposed to attack graphs. A rewiring operation rewires an existing edge from one node to another node, which can be formally defined as below.

Definition 6.1 (Rewiring Operation) A rewiring operation $a = (v_{fir}, v_{sec}, v_{thi})$ involves three nodes, where $v_{sec} \in \mathcal{N}(v_{fir})$ and $v_{thi} \in \mathcal{N}^2(v_{fir})/\mathcal{N}(v_{fir})$ with $\mathcal{N}^2(v_{fir})$ denoting the 2-hop neighbors of the node v_i . The rewiring operation a deletes the existing edge between nodes v_{fir} and v_{sec} and add a new edge between nodes v_{fir} and v_{thi} .

The rewiring operation is theoretically and empirically shown to be less noticeable than other operations such as deleting/adding edges in (Ma et al., 2020a). The constraint space of the ReWatt attack is defined based on the rewiring operation as:

$$\Phi(\mathcal{G}) = \{\mathcal{G}' | \text{if } \mathcal{G}' \text{ can be obtained by applying at most } \Delta \text{ rewiring operations to } \mathcal{G}\},$$

where the budget Δ is usually defined based on the size of the graph as $p \cdot |\mathcal{E}|$ with $p \in (0, 1)$. The attacking procedure is modeled as a Finite Markov Decision Process (MDP), which is defined as:

- **Action:** The action space consists of all the valid rewiring operations as defined in Definition 6.1.
- **State:** The state s_t at the time step t is the intermediate graph \mathcal{G}_t , which is obtained by applying one rewiring operation on the intermediate graph \mathcal{G}_{t-1} .
- **State Transition Dynamics:** Given an action $a_t = (v_{\text{fir}}, v_{\text{sec}}, v_{\text{thi}})$, the state is transited from the state s_t to state s_{t+1} by deleting an edge between v_{fir} and v_{sec} , and adding an edge to connect v_{fir} with v_{thi} in the state s_t .
- **Reward Design:** The goal of the attacker is to modify the graph such that the predicted label is different from the one predicted for the original graph (or the initial state s_1). Furthermore, the attacker is encouraged to take few actions to achieve the goal so that the modifications to the graph structure are minimal. Hence, a positive reward is granted if the action leads to the change of the label; otherwise, a negative reward is assigned. Specifically, the reward $R(s_t, a_t)$ can be defined as follows:

$$R(s_t, a_t) = \begin{cases} 1 & \text{if } f_{GNN}(s_t; \Theta) \neq f_{GNN}(s_1; \Theta); \\ n_r & \text{if } f_{GNN}(s_t; \Theta) = f_{GNN}(s_1; \Theta). \end{cases}$$

where n_r is the negative reward, which is adaptive dependent on the size of graph as $n_r = -\frac{1}{p \cdot |\mathcal{E}|}$. Note that we abuse the definition $f_{GNN}(\mathcal{G}; \Theta)$ a little bit to have the predicted label as its output.

- **Termination:** The attacker stops the attacking process either when the predicted label has been changed or when the resulting graph is not in the constraint space $\Phi(\mathcal{G})$.

Various reinforcement learning techniques can be adopted to learn this MDP. Specifically, in (Ma et al., 2020a), graph neural networks based policy networks are designed to choose the rewiring actions according to the state and the policy gradient algorithm (Sutton et al., 2000) is employed to train the policy networks.

6.3 Graph Adversarial Defenses

To defend against the adversarial attacks on graph-structured data, various defense techniques have been proposed. These defense techniques can be majorly classified to four different categories: 1) graph adversarial training, which incorporates adversarial samples into the training procedure to improve the robustness of the models; 2) graph purification, which tries to detect the adversarial attacks and remove them from the attacked graph to generate a clean graph; 3) graph attention, which identifies the adversarial attacks during the

training stage and gives them less attention while training the model; and 4) graph structure learning, which aims to learn a clean graph from the attacked graph while jointly training the graph neural network model. Next, we introduce some representative methods in each category.

6.3.1 Graph Adversarial Training

The idea of adversarial training (Goodfellow et al., 2014b) is to incorporate the adversarial examples into the training stage of the model; hence, the robustness of the model can be improved. It has demonstrated its effectiveness in training robust deep models in the image domain (Goodfellow et al., 2014b). There are usually two stages in adversarial training: 1) generating adversarial attacks, and 2) training the model with these attacks. In the graph domain, the adversarial attackers are allowed to modify the graph structure and/or node features. Hence, the graph adversarial training techniques can be categorized according to the adversarial attacks they incorporate: 1) only attacks on graph structure \mathbf{A} ; 2) only attacks on node features \mathbf{F} ; and 3) attacks on both graph structure \mathbf{A} and node features \mathbf{F} . Next, we introduce representative graph adversarial training techniques.

Graph Adversarial Training on Graph Structure

In (Dai et al., 2018), an intuitive and simple graph adversarial training method is proposed. During the training stage, edges are randomly dropped from the input graph to generate the “adversarial attacked graphs”. While being simple and not very effective to improve the robustness, this is the first technique to explore the adversarial training on graph-structured data. Later on, a graph adversarial training technique based on the PGD topology attack is proposed. In detail, this adversarial training procedure can be formulated as the following min-max optimization problem:

$$\min_{\Theta} \max_{\mathbf{s} \in \mathcal{S}} -\mathcal{L}(\mathbf{s}; \Theta), \quad (6.13)$$

where the objective $\mathcal{L}(\mathbf{s}; \Theta)$ is defined as similar to Eq. (6.4) over the entire training set \mathcal{V}_l as:

$$\begin{aligned} \mathcal{L}(\mathbf{s}; \Theta) &= \sum_{v_i \in \mathcal{V}_l} \ell(f_{GNN}(\mathcal{G}'; \Theta)_i, y_i) \\ \text{subject to } & \|\mathbf{s}\|_0 \leq \Delta, \mathbf{s} \in \{0, 1\}^{N \times (N-1)/2}. \end{aligned}$$

Solving the min-max problem in Eq. (6.13) is to minimize the training loss under the perturbation in graph structure generated by @Comment: not necessarily PGD, you can remove "PGD topology attack"@ the PGD topology at-

tack algorithm. The minimization problem and the maximization problem are processed in an alternative way. In particular, the maximization problem can be solved using the PGD algorithm, as introduced in Section 6.2.2. It results in a continuous solution of \mathbf{s} . The non-binary adjacency matrix \mathbf{A} is generated according to the continuous \mathbf{s} . It serves as the adversarial graph for the minimization problem to learn the parameters Θ for the classification model.

Graph Adversarial Training on Node Features

GraphAT (Feng et al., 2019a) incorporates node features based adversarial samples into the training procedure of the classification model. The adversarial samples are generated by perturbing the node features of the clean node samples such that the neighboring nodes are likely to be assigned to different labels. One important assumption in graph neural network models is that neighboring nodes tend to be similar with each other. Thus, the adversarial attacks on the node features make the model likely to make mistakes. These generated adversarial samples are then utilized in the training procedure in the form of a regularization term. Specifically, the graph adversarial training procedure can be expressed as the following min-max optimization problem:

$$\begin{aligned} \min_{\Theta} \mathcal{L}_{train} + \beta \sum_{v_i \in \mathcal{V}} \sum_{v_j \in \mathcal{N}(v_i)} d(f_{GNN}(\mathbf{A}, \mathbf{F} \star \mathbf{r}_i^g; \Theta)_i, f_{GNN}(\mathbf{A}, \mathbf{F}; \Theta)_j); \\ \mathbf{r}_i^g = \arg \max_{\mathbf{r}_i, \|\mathbf{r}_i\| \leq \epsilon} \sum_{v_j \in \mathcal{N}(v_i)} d(f_{GNN}(\mathbf{A}, \mathbf{F} \star \mathbf{r}_i; \Theta)_i, f_{GNN}(\mathbf{A}, \mathbf{F}; \Theta)_j); \end{aligned} \quad (6.14)$$

where the maximization problem generates the adversarial node features for the nodes, which break the smoothness between the connected nodes. While the minimization problem learns the parameters Θ , which not only enforce a small training error but also encourage the smoothness between the adversarial samples and their neighbors via the additional regularization term. In Eq. (6.14), \mathcal{L}_{train} is the loss defined in Eq. (5.49), $\mathbf{r}_i \in \mathbb{R}^{1 \times d}$ is a row-wise adversarial vector and the operation $\mathbf{F} \star \mathbf{r}_i$ means to add \mathbf{r}_i into the i -th row of \mathbf{F} , i.e., adding adversarial noise to the node v_i 's features. $f_{GNN}(\mathbf{A}, \mathbf{F} \star \mathbf{r}_i^g; \Theta)_i$ denotes the i -th row of $f_{GNN}(\mathbf{A}, \mathbf{F} \star \mathbf{r}_i^g; \Theta)$, which is the predicted logits for node v_i . The function $d(\cdot, \cdot)$ is the KL-divergence (Joyce, 2011), which measures the distance between the predicted logits. The minimization problem and the maximization problem are processed in an alternative way. Specifically,

Graph Adversarial Training on Graph Structures and Node Features

Given the challenges from the discrete nature of the graph structure \mathbf{A} and the node features \mathbf{F} , a graph adversarial training technique proposes to modify the continuous output of the first graph filtering layer $\mathbf{F}^{(1)}$ (Jin and Zhang, n.d.).

The method generates adversarial attacks for the first hidden representation $\mathbf{F}^{(1)}$ and incorporates them into the model training stage. Specifically, it can be modeled as the following min-max optimization problem:

$$\min_{\Theta} \max_{\zeta \in D} \mathcal{L}_{train}(\mathbf{A}, \mathbf{F}^{(1)} + \zeta; \Theta), \quad (6.15)$$

where the maximization problem generates a small adversarial perturbation on the first layer hidden representation $\mathbf{F}^{(1)}$, which indirectly represents the perturbation in the graph structure \mathbf{A} and the node features \mathbf{F} . The minimization problem learns the parameters of the model while incorporating the generated perturbation into the learning procedure. ζ is the adversarial noise to be learned and D denotes the constraint domain of the noise, which is defined as follows:

$$D = \{\zeta; \|\zeta_i\|_2 \leq \Delta\};$$

where ζ_i denotes the i -th row of ζ and Δ is a predefined budget. Note that in Eq. (6.15), $\mathcal{L}_{train}(\mathbf{A}, \mathbf{F}^{(1)} + \zeta; \Theta)$ is overloaded to denote a similar loss as Eq. (5.49) except that it is based on the perturbed hidden representation $\mathbf{F}^{(1)} + \zeta$. Similar to other adversarial training techniques, the minimization problem and the maximization problem are processed in an alternative way.

6.3.2 Graph Purification

Graph purification based defense techniques have been developed to defend against the adversarial attacks on graph structure. Specifically, these methods try to identify adversarial attacks in a given graph and remove them before using the graph for model training. Hence, most of the graph purification methods can be viewed as performing pre-processing on graphs. Next, we introduce two defense techniques based on graph purification.

Removing Edges with Low Feature Similarity

Empirical explorations show that many adversarial attack methods (e.g., net-tack and IG-FGSM) tend to add edges to connect nodes with significantly different node features (Wu et al., 2019; Jin et al., 2020a). Similarly, when removing edges, these attack methods tend to remove the edges between nodes with similar features. Hence, based on these observations, a simple and efficient approach is proposed in (Wu et al., 2019), which tries to remove the edges between nodes with very different features. More specifically, a scoring function is proposed to measure the similarity between the node features. For example, for binary features, the Jaccard similarity (Tan et al., 2016) is adopted as the scoring function. The edges with scores that are smaller than a threshold are

then removed from the graph. The pre-processed graph is then employed for training the graph neural network models.

Low-rank Approximation of Adjacency Matrix

Empirical studies are carried out to analyze the adversarial perturbations generated by netattack (Entezari et al., 2020; Jin et al., 2020a). It turns out that Netattack tends to perturb the graph structure to increase the adjacency matrix's rank. It is argued that the number of low-value singular values of the adjacency matrix is increased. Hence, Singular Value Decomposition(SVD) based pre-processing method is proposed in (Entezari et al., 2020) to remove the adversarial perturbation added into the graph structure. Specifically, given an adjacency matrix \mathbf{A} of a graph, SVD is used to decompose it, and then only the top- k singular values are kept to reconstruct (approximate) the adjacency matrix. The reconstructed adjacency matrix is then treated as the purified graph structure and utilized to train the graph neural network models.

6.3.3 Graph Attention

Instead of removing the adversarial attacks from the graph as the graph purification-based methods, the graph attention-based methods aim to learn to focus less on the nodes/edges affected by the adversarial attacks in the graph. The graph attention based defense techniques are usually end-to-end. In other words, they include the graph attention mechanism as a building component in the graph neural network models. Next, we introduce two attention based defense techniques.

RGCN: Modelling Hidden Representations with Gaussian Distribution

To improve the robustness of the graph neural network models, instead of plain vectors, multivariate Gaussian distribution is adopted to model the hidden representations in (Zhu et al., 2019a). The adversarial attacks generate perturbations on the graph structure, which, in turn, cause abnormal effects on the node representations. While the plain-vector based hidden representations cannot adapt themselves to the adversarial impacts, the Gaussian distribution based hidden representations can absorb the effects caused by the adversarial attacks and thus can lead to more robust hidden representations. Furthermore, a variance-based attention mechanism is introduced to prevent the adversarial effects from propagation across the graph. Specifically, the nodes affected by adversarial attacks typically have large variances as the attacks tend to connect nodes with very different features and/or from different communities. Hence, when performing neighbor information aggregation to update node features,

less attention is assigned to those neighbors with large variances to prevent the adversarial effects from propagation. Next, we describe the details of RGCN-Filter – the graph filter built upon the intuitions above.

RGCN-Filter is built upon the GCN-Filter as described in Eq. (5.22). For the ease of description, we recall Eq. (5.22) as follows:

$$\mathbf{F}'_i = \sum_{v_j \in \mathcal{N}(v_i) \cup \{v_i\}} \frac{1}{\sqrt{\tilde{\mathbf{d}}_i \tilde{\mathbf{d}}_j}} \mathbf{F}_j \Theta,$$

where $\tilde{\mathbf{d}}_i = \tilde{\mathbf{D}}_{i,i}$. Instead of plain vectors, RGCN-Filter utilizes Gaussian distributions to model the node representations. For the node v_i , its representation is denoted as:

$$\mathbf{F}_i \sim \mathcal{N}(\boldsymbol{\mu}_i, \text{diag}(\boldsymbol{\sigma}_i)),$$

where $\boldsymbol{\mu}_i \in \mathbb{R}^d$ is the mean of the representations and $\text{diag}(\boldsymbol{\sigma}_i) \in \mathbb{R}^{d \times d}$ is the diagonal variance matrix of the representations. When updating the node representations, it has two aggregation processes on the mean and the variance of the representations. In addition, an attention mechanism based on the variance of representations is introduced to prevent the adversarial effects from propagating across the graph. Specifically, for nodes with larger variances, smaller attention scores are assigned. The attention score for node v_i is modeled through a smooth exponential function as:

$$\mathbf{a}_i = \exp(-\gamma \boldsymbol{\sigma}_i),$$

where γ is a hyperparameter. With the definition of the Gaussian based representations and the attention scores, the update process for the representation of node v_i can be stated as:

$$\mathbf{F}'_i \sim \mathcal{N}(\boldsymbol{\mu}'_i, \text{diag}(\boldsymbol{\sigma}'_i)),$$

where

$$\begin{aligned} \boldsymbol{\mu}'_i &= \alpha \left(\sum_{v_j \in \mathcal{N}(v_i) \cup \{v_i\}} \frac{1}{\sqrt{\tilde{\mathbf{d}}_i \tilde{\mathbf{d}}_j}} (\boldsymbol{\mu}_j \odot \mathbf{a}_j) \Theta_\mu \right); \\ \boldsymbol{\sigma}'_i &= \alpha \left(\sum_{v_j \in \mathcal{N}(v_i) \cup \{v_i\}} \frac{1}{\tilde{\mathbf{d}}_i \tilde{\mathbf{d}}_j} (\boldsymbol{\sigma}_j \odot \mathbf{a}_j \odot \mathbf{a}_j) \Theta_\sigma \right). \end{aligned}$$

Here α denotes non-linear activation functions, \odot is the Hadamard multiplication operator, Θ_μ and Θ_σ are learnable parameters to transform the aggregated information of mean and variance, respectively.

PA-GNN: Transferring Robustness From Clean Graphs

Instead of penalizing the affected nodes as RGCN, PA-GNN (Tang et al., 2019) aims to penalize the adversarial edges for preventing the adversarial effects from propagation through the graph. Specifically, it aims to learn an attention mechanism that can assign low attention scores to adversarial edges. However, typically, we do not have knowledge about the adversarial edges. Hence, PA-GNN aims to transfer this knowledge from clean graphs where adversarial attacks can be generated to serve as supervision signals to learn the desired attention scores.

The PA-GNN model is built upon the graph attention network as described in Eq. (5.27), which can be written as:

$$\mathbf{F}'_i = \sum_{v_j \in \mathcal{N}(v_i) \cup \{v_i\}} a_{ij} \mathbf{F}_j \Theta, \quad (6.16)$$

where a_{ij} denotes the attention score for aggregating information from node v_j to node v_i through the edge e_{ij} . Intuitively, we desire the attention scores of the adversarial edges to be small so that the adversarial effects can be prevented from propagation. Assume that we know a set of adversarial edges, which is denoted as \mathcal{E}_{ad} , and the set of the remaining “clean” edges can be denoted as $\mathcal{E}/\mathcal{E}_{ad}$. To ensure that the attention scores for the adversarial edges are small, the following term can be added to the training loss to penalize the adversarial edges.

$$\mathcal{L}_{\text{dist}} = - \min \left(\eta, \mathbb{E}_{\substack{e_{ij} \in \mathcal{E}/\mathcal{E}_{ad} \\ 1 \leq l \leq L}} a_{ij}^{(l)} - \mathbb{E}_{\substack{e_{ij} \in \mathcal{E}_{ad} \\ 1 \leq l \leq L}} a_{ij}^{(l)} \right)$$

where $a_{ij}^{(l)}$ is the attention score assigned to edge e_{ij} in the l -th graph filtering layer, L is the total number of graph filtering layers in the model, and η is a hyper parameter controlling the margin between the two expectations. The expectations of the attention coefficients are estimated by their empirical means as:

$$\mathbb{E}_{\substack{e_{ij} \in \mathcal{E}/\mathcal{E}_{ad} \\ 1 \leq l \leq L}} a_{ij}^{(l)} = \frac{1}{L|\mathcal{E}/\mathcal{E}_{ad}|} \sum_{l=1}^L \sum_{e_{ij} \in \mathcal{E}/\mathcal{E}_{ad}} a_{ij}^{(l)}$$

$$\mathbb{E}_{\substack{e_{ij} \in \mathcal{E}_{ad} \\ 1 \leq l \leq L}} a_{ij}^{(l)} = \frac{1}{L|\mathcal{E}_{ad}|} \sum_{l=1}^L \sum_{e_{ij} \in \mathcal{E}_{ad}} a_{ij}^{(l)},$$

where $|\cdot|$ denotes the cardinality of a set. To train the classification model while assigning lower attention scores to the adversarial edges, we combine the loss

\mathcal{L}_{dist} with the semi-supervised node classification loss \mathcal{L}_{train} in Eq. (5.49) as:

$$\min_{\Theta} \mathcal{L} = \min_{\Theta} (\mathcal{L}_{train} + \lambda \mathcal{L}_{dist}) \quad (6.17)$$

where λ is a hyper-parameter balancing the importance between the two types of loss. So far, the set of adversarial edges \mathcal{E}_{ad} is assumed to be known, which is impractical. Hence, instead of directly formulating and optimizing Eq. (6.17), we try to transfer the ability of assigning low attention scores to adversarial edges from those graphs with known adversarial edges. To obtain the graphs with known adversarial edges, we collect clean graphs from similar domains as the given graph, and apply existing adversarial attacks such as *metattack* to generate attacked graphs. Then, we can learn the ability from these attacked graphs and transfer it to the given graph. Next, we first briefly discuss the overall framework of PA-GNN and then detail the process of learning the attention mechanism and transferring its ability to the target graph. As shown in Figure 6.1, given a set of K clean graphs denoted as $\{\mathcal{G}_1, \dots, \mathcal{G}_K\}$, we use existing attacking methods such as *metattack* to generate a set of adversarial edges \mathcal{E}_{ad}^i for each graph. Furthermore, the node set \mathcal{V}^i in each graph is split into the training set \mathcal{V}_l^i and the test set \mathcal{V}_u^i . Then, we try to optimize the loss function in Eq. (6.17) for each graph. Specifically, for the graph \mathcal{G}_i , we denote its corresponding loss as \mathcal{L}_i . As inspired by the meta-optimization algorithm MAML (Finn et al., 2017), all graphs share the same initialization Θ and the goal is to learn these parameters Θ that can be easily adapted to learning the task on each graph, separately. As shown in Figure 6.1, the ideal shared initialization parameters Θ are learned through meta-optimization, which we will detail later. These shared parameters Θ are considered to carry the ability of assigning lower attention scores to the adversarial edges. To transfer this ability to the given graph \mathcal{G} , we use the shared parameters Θ as the initialization parameters to train the graph neural network model on graph \mathcal{G} and the obtained fine-tuned parameters are denoted as $\Theta_{\mathcal{G}}$. Next, we describe the meta-optimization algorithm adopted from MAML to learn the optimal shared parameters Θ .

The optimization process first adapts (fine-tunes) the parameters Θ to each graph \mathcal{G}_i by using the gradient descent method as:

$$\Theta'_i = \Theta - \alpha \nabla_{\Theta} \mathcal{L}_i^{tr}(\Theta),$$

where Θ'_i is the specific parameters for the learning task on the graph \mathcal{G}_i and \mathcal{L}_i^{tr} denotes the loss in Eq.(6.17) evaluated on the corresponding training set \mathcal{V}_l^i . The test sets of all the graphs $\{\mathcal{V}_u^1, \dots, \mathcal{V}_u^K\}$ are then used to update the shared parameters Θ such that each of the learned classifiers can work well for

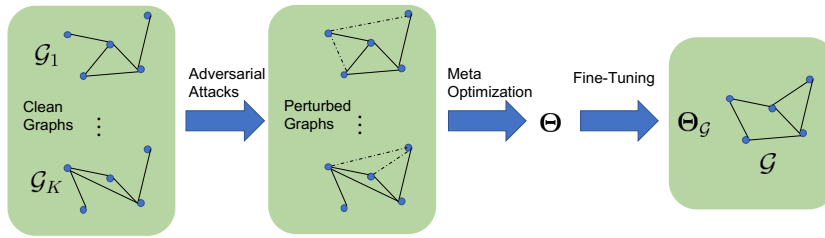

Figure 6.1 The overall framework of PA-GNN

each graph. Hence, the objective of the meta-optimization can be summarized as:

$$\min_{\Theta} \sum_{i=1}^K \mathcal{L}_i^{te}(\Theta'_i) = \min_{\Theta} \sum_{i=1}^K \mathcal{L}_i^{te}(\theta - \alpha \nabla_{\Theta} \mathcal{L}_i^{tr}(\Theta)),$$

where $\mathcal{L}_i^{te}(\Theta'_i)$ denotes the loss in Eq. (6.17) evaluated on the corresponding test set \mathcal{V}'_u . The shared parameters Θ can be updated using SGD as:

$$\Theta \leftarrow \Theta - \beta \nabla_{\Theta} \sum_{i=1}^K \mathcal{L}_i^{te}(\Theta'_i).$$

Once the shared parameters Θ are learned, they can be used as the initialization for the learning task on the given graph \mathcal{G} .

6.3.4 Graph Structure Learning

In Section 6.3.2, we introduced the graph purification based defense techniques. They often first identify the adversarial attacks and then remove them from the attacked graph before training the GNN models. Those methods typically consist of two stages, i.e., the purification stage and the model training stage. With such a two-stage strategy, the purified graphs might be sub-optimal to learn the model parameters for down-stream tasks. In (Jin et al., 2020b), an end-to-end method, which jointly purifies the graph structure and learns the model parameters, is proposed to train robust graph neural network models. As described in Section 6.3.2, the adversarial attacks usually tend to add edges to connect nodes with different node features and increase the rank of the adjacency matrix. Hence, to reduce the effects of the adversarial attacks, Pro-GNN (Jin et al., 2020b) aims to learn a new adjacency matrix \mathbf{S} , which is close to the original adjacency matrix \mathbf{A} , while being low-rank and also ensuring feature smoothing. Specifically, the purified adjacency matrix \mathbf{S} and the model

parameters Θ can be learned by solving the following optimization problem:

$$\min_{\Theta, \mathbf{S}} \mathcal{L}_{train}(\mathbf{S}, \mathbf{F}; \Theta) + \|\mathbf{A} - \mathbf{S}\|_F^2 + \beta_1 \|\mathbf{S}\|_1 + \beta_2 \|\mathbf{S}\|_* + \beta_3 \cdot tr(\mathbf{F}^T \mathbf{L} \mathbf{F}), \quad (6.18)$$

where the term $\|\mathbf{A} - \mathbf{S}\|_F^2$ is to make sure that the learned matrix \mathbf{S} is close to the original adjacency matrix; the L_1 norm of the learned adjacency matrix $\|\mathbf{S}\|_1$ allows the learned matrix \mathbf{S} to be sparse; $\|\mathbf{S}\|_*$ is the nuclear norm to ensure that the learned matrix \mathbf{S} is low-rank; and the term $tr(\mathbf{F}^T \mathbf{L} \mathbf{F})$ is to force the feature smoothness. Note that the feature matrix \mathbf{F} is fixed, and the term $tr(\mathbf{F}^T \mathbf{L} \mathbf{F})$ force the Laplacian matrix \mathbf{L} , built upon \mathbf{S} , to ensure that the features are smooth. The hyper-parameters β_1, β_2 and β_3 control the balance between these terms. The matrix \mathbf{S} and the model parameters Θ can be optimized alternatively as:

- **Update Θ :** We fix the matrix \mathbf{S} and remove the terms that are irrelevant to \mathbf{S} in Eq. (6.18). The optimization problem is then re-formulated as:

$$\min_{\Theta} \mathcal{L}_{train}(\mathbf{S}, \mathbf{F}; \Theta).$$

- **Update \mathbf{S} :** We fix the model parameters Θ and optimize the matrix \mathbf{S} by solving the following optimization problem:

$$\min_{\mathbf{S}} \mathcal{L}_{train}(\mathbf{S}, \mathbf{F}; \Theta) + \|\mathbf{A} - \mathbf{S}\|_F^2 + \alpha \|\mathbf{S}\|_1 + \beta \|\mathbf{S}\|_* + \lambda \cdot tr(\mathbf{F}^T \mathbf{L} \mathbf{F}).$$

6.4 Conclusion

In this chapter, we focus on the robustness of the graph neural networks, which is critical for applying graph neural network models to real-world applications. Specifically, we first describe various adversarial attack methods designed for graph-structured data including white-box, gray-box and black-box attacks. They demonstrate that the graph neural network models are vulnerable to deliberately designed unnoticeable perturbations on graph structures and/or node features. Then, we introduced a variety of defense techniques to improve the robustness of the graph neural network models including graph adversarial training, graph purification, graph attention and graph structure learning.

6.5 Further Reading

The research area of robust graph neural networks is still fast evolving. Thus, a comprehensive repository for graph adversarial attacks and defenses has been

built (Li et al., 2020a). The repository enables systematical experiments on existing algorithms and efficient new algorithm development. An empirical study has been conducted based on the repository (Jin et al., 2020a). It provides deep insights about graph adversarial attacks and defenses that can deepen our knowledge and foster this research field. In addition to the graph domain, there are adversarial attacks and defenses in other domains such as images (Yuan et al., 2019; Xu et al., 2019b; Ren et al., 2020) and texts (Xu et al., 2019b; Zhang et al., 2020).

7

Scalable Graph Neural Networks

7.1 Introduction

Graph Neural Networks suffer from severe scalability issue, which prevents them from being adopted to large-scale graphs. Take the GCN-Filter based model for the node classification task as an example, where we adopt gradient-based methods to minimize the following loss function (the same as Eq. (5.49)):

$$\mathcal{L}_{train} = \sum_{v_i \in \mathcal{V}_l} \ell(f_{GCN}(\mathbf{A}, \mathbf{F}; \Theta)_i, y_i), \quad (7.1)$$

where $\ell()$ is a loss function and $f_{GCN}(\mathbf{A}, \mathbf{F}; \Theta)$ consists of L GCN-Filter layers as described in Eq. (5.21) as:

$$\mathbf{F}^{(l)} = \hat{\mathbf{A}}\mathbf{F}^{(l-1)}\Theta^{(l-1)}, \quad l = 1, \dots, L. \quad (7.2)$$

where $\hat{\mathbf{A}}$ is utilized to denote $\tilde{\mathbf{D}}^{-\frac{1}{2}}\tilde{\mathbf{A}}\tilde{\mathbf{D}}^{-\frac{1}{2}}$ and $\mathbf{F}^{(0)} = \mathbf{F}$. For the convenience of analysis, the node representations in all layers are assumed to have the same dimension d . Note that, in this formulation, we ignore the activation layer that can be added between the graph filtering layers. The parameters Θ in Eq.(7.1) include $\Theta^{(l)}$, $l = 1, \dots, L$ and the parameters Θ_2 to perform the prediction as Eq. (5.47). One step of the gradient descent algorithm to minimize the loss can be described as:

$$\Theta \leftarrow \Theta - \eta \cdot \nabla_{\Theta} \mathcal{L}_{train},$$

where η is the learning rate and the gradient $\nabla_{\Theta} \mathcal{L}_{train}$ needs to be evaluated over the entire training set \mathcal{V}_l . Furthermore, due to the design of the GCN-Filter layers as shown in Eq. (7.2), when evaluating \mathcal{L}_{train} in the forward pass, all nodes in \mathcal{V} are involved in the calculation as all node representations are computed in each layer. Hence, in the forward pass of each training epoch, the representations for all nodes and the parameters in each graph filtering layer need to be

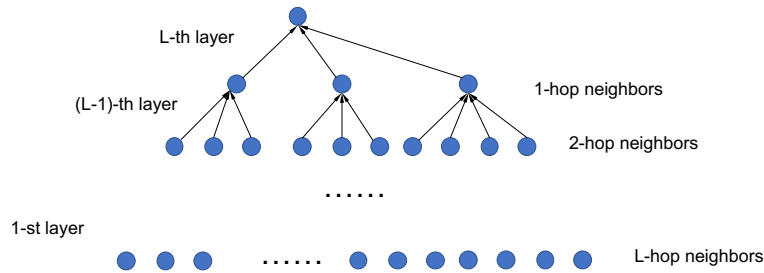

Figure 7.1 The aggregation process

stored in the memory, which becomes prohibitively large when the scale of the graph grows. Specifically, we can calculate the required memory explicitly as follows. During the forward pass, the normalized adjacency matrix $\hat{\mathbf{A}}$, the node representations in all layers $\mathbf{F}^{(l)}$ and the parameters in all layers $\Theta^{(l)}$ need to be stored in the memory, which requires $O(|\mathcal{E}|)$, $O(L \cdot |\mathcal{V}| \cdot d)$ and $O(L \cdot d^2)$, respectively. Thus, in total, the required memory is $O(|\mathcal{E}| + L \cdot |\mathcal{V}| \cdot d + L \cdot d^2)$. When the size of the graph is large, i.e., $|\mathcal{V}|$ and/or $|\mathcal{E}|$ are large, it becomes impossible to fit them into the memory. Furthermore, the calculation in the form of Eq. (7.2) is not efficient as the final representations (or the representations after the L -th layer) for the unlabeled nodes in \mathcal{V}_u are also calculated, although they are not required for evaluating Eq. (7.1). In detail, $O(L \cdot (|\mathcal{E}| \cdot d + |\mathcal{V}| \cdot d^2)) = O(L \cdot |\mathcal{V}| \cdot d^2)$ operations are required to perform the full epoch of the forward process. As in traditional deep learning scenario, a natural idea to reduce the memory requirement during training is to adopt Stochastic Gradient Descent (SGD). Instead of using all the training samples, it utilizes a single training sample (or a subset of training samples) to estimate the gradient. However, adopting SGD in graph-structured data is not as convenient as that in the traditional scenario since the training samples in Eq. (7.1) are connected to other labeled/unlabeled samples in the graph. To calculate the loss $\ell(f_{GCN}(\mathbf{A}, \mathbf{F}; \Theta)_i, y_i)$ for node v_i , the node representations of many other nodes (or even the entire graph as indicated by the adjacency matrix $\hat{\mathbf{A}}$) are also involved due to the graph filtering operations as described in Eq. (7.2). To perceive the calculation more clearly, we analyze Eq. (7.2) from a local view for a node v_i as:

$$\mathbf{F}_i^{(l)} = \sum_{v_j \in \tilde{\mathcal{N}}(v_i)} \hat{\mathbf{A}}_{i,j} \mathbf{F}_j^{(l-1)} \Theta^{(l-1)}, \quad l = 1, \dots, L, \quad (7.3)$$

which takes the form of aggregating information from neighboring nodes. Note that we use $\mathbf{F}_i^{(l)}$ to denote the node representation for node v_i after l -th graph fil-

tering layer; $\hat{\mathbf{A}}_{i,j}$ to indicate the i, j -th element of $\hat{\mathbf{A}}$; and $\tilde{\mathcal{N}}(v_i) = \mathcal{N}(v_i) \cup \{v_i\}$ to denote the set of neighbors of node v_i including itself. Hence, clearly, as shown in Figure 7.1, from a top-down perspective, i.e., from the L -th layer to the input layer, to calculate the representation of node v_i in the L -th graph filtering layer (the output layer), only the representations of its neighbors (including itself) in the $(L-1)$ -th layer are required. To calculate the $(L-1)$ -th layer representation for a node $v_j \in \tilde{\mathcal{N}}(v_i)$, all the $(L-2)$ -th layer representations of its neighbors are required. The neighbors of all nodes in $\tilde{\mathcal{N}}(v_i)$ are the “neighbors of neighbors” of node v_i , i.e., the 2-hop neighbors of node v_i . In general, computing the loss term for node v_i needs the representation of node v_i after the L -th layer and its l -hop neighbors are required by the $(L-l+1)$ -th graph filtering layer. Specifically, its L -hop neighbors are required by the input layer (i.e. the first layer). Hence, for the entire process of calculation, all nodes with the L -hop of node v_i are involved. Based on this analysis, we rewrite the loss for the node v_i as:

$$\ell(f_{GCN}(\mathbf{A}, \mathbf{F}; \Theta)_{i, y_i}) = \ell(f_{GCN}(\mathbf{A}\{\mathcal{N}^L(v_i)\}, \mathbf{F}\{\mathcal{N}^L(v_i)\}; \Theta), y_i), \quad (7.4)$$

where $\mathcal{N}^L(v_i)$ is the set of nodes within L -hop away of node v_i , i.e., all nodes shown in Figure 7.1, $\mathbf{A}\{\mathcal{N}^L(v_i)\}$ denotes the induced structure on $\mathcal{N}^L(v_i)$ (i.e., the rows and columns in the adjacent matrix corresponding to nodes in $\mathcal{N}^L(v_i)$ are retrieved) and $\mathbf{F}\{\mathcal{N}^L(v_i)\}$ indicates the input features for nodes in $\mathcal{N}^L(v_i)$. Typically, the mini-batch SGD algorithm, where a min-batch of training instances are sampled from \mathcal{V}_l to estimate the gradient, is used for parameter updates. The batch-wise loss function can be expressed as:

$$\mathcal{L}_{\mathcal{B}} = \sum_{v_i \in \mathcal{B}} \ell(f_{GCN}(\mathbf{A}\{\mathcal{N}^L(v_i)\}, \mathbf{F}\{\mathcal{N}^L(v_i)\}; \Theta), y_i), \quad (7.5)$$

where $\mathcal{B} \subset \mathcal{V}_l$ is the sampled mini-batch. However, even if SGD is adopted for optimization, the memory requirement can be still high. The major issue is that, as shown in Figure 7.1, the node set $\mathcal{N}^L(v_i)$ expands exponentially as the number of the graph filtering layers L increases. Specifically, the number of nodes in $\mathcal{N}^L(v_i)$ is in the order of deg^L , where deg denotes the average degree of the nodes in the graph. Thus, to perform SGD optimization, $O(deg^L \cdot d)$ memory is required to store the node representations. Furthermore, in practice, we need to prepare the memory that is sufficient for the “worst” batch which requires the “most” memory instead of the average one. This could lead to quite a lot of memory when there is a node with a large degree in the batch, as many other nodes are involved due to the inclusion of this large degree node. This issue of exponentially growing neighborhood is usually referred as “neighborhood expansion” or “neighborhood explosion” (Chen et al., 2018a,b; Huang et al., 2018). When L is larger than the diameter of the graph, we have $\mathcal{N}^L(v_i) = \mathcal{V}$. It

means that the entire node set is required for calculation, which demonstrates an extreme case of neighborhood explosion. Furthermore, the “neighborhood explosion” issue also impacts the time efficiency of the SGD algorithm. Specifically, the time complexity to calculate the final representation $\mathbf{F}_i^{(L)}$ for the node v_i is $O(\text{deg}^L \cdot (\text{deg} \cdot d + d^2))$, which is $O(\text{deg}^L \cdot d^2)$ as deg is usually much smaller than d . Then, the time complexity to run an epoch over the entire training set \mathcal{V}_l is $O(|\mathcal{V}_l| \cdot \text{deg}^L \cdot d^2)$ when we assume that each batch only contains a single training sample. When the batch size $|\mathcal{B}| > 1$, the time complexity for an epoch can be lower, as in each batch \mathcal{B} , some of the involved nodes may exist in $\mathcal{N}^L(v_i)$ for several samples v_i in the batch \mathcal{B} and their representations can be shared during the calculation. Compared to the full gradient algorithm, which takes $O(L \cdot |\mathcal{V}| \cdot d^2)$ to run a full epoch, the time complexity for SGD can be even higher when L is large although no extra final representations for unlabeled nodes are calculated.

Although we introduce the “neighborhood explosion” issue for the GNN models with GCN-Filters, this issue exists in GNN models with other graph filters as long as they follow a neighborhood aggregation process as Eq. (7.3). In this chapter, without loss of generality, the discussion and analysis are based on the GCN-Filters. To solve the “neighborhood explosion” issue and correspondingly improve the scalability of graph neural network models, various neighborhood sampling methods have been proposed. The main idea of sampling methods is to reduce the number of nodes involved in the calculation of Eq. (7.5) and hence lower the required time and memory to perform the calculation. There are mainly three types of sampling methods:

- **Node-wise sampling methods.** To calculate the representation for a node v_i with Eq. (7.3), in each layer, a set of nodes is sampled from its neighbors. Then, instead of aggregating information from its entire neighborhood, the node representation will only be calculated based on these sampled nodes.
- **Layer-wise sampling methods.** A set of nodes is sampled for the node representation calculation of the entire layer. In other words, to calculate $\mathbf{F}_i^{(l)}$ and $\mathbf{F}_j^{(l)}$ for nodes v_i and v_j , the same set of sampled nodes are utilized to perform the calculation.
- **Subgraph-wise sampling methods.** A subgraph is sampled from the original graph. Then, the node representation learning is based on the sampled subgraph.

In this chapter, we detail and analyze representative algorithms from each group of sampling methods.

7.2 Node-wise Sampling Methods

The node-wise aggregation process in Eq.(7.3) can be rewritten as:

$$\mathbf{F}_i^{(l)} = |\tilde{\mathcal{N}}(v_i)| \sum_{v_j \in \tilde{\mathcal{N}}(v_i)} \frac{1}{|\tilde{\mathcal{N}}(v_i)|} \hat{\mathbf{A}}_{i,j} \mathbf{F}_j^{(l-1)} \Theta^{(l-1)}, \quad (7.6)$$

which can be regarded as the following expectation form:

$$\mathbf{F}_i^{(l)} = |\tilde{\mathcal{N}}(v_i)| \cdot \mathbb{E}[\mathcal{F}_{v_i}] \quad (7.7)$$

where \mathcal{F}_{v_i} is a discrete random variable as defined below:

$$p(\mathcal{F}_{v_i} = \hat{\mathbf{A}}_{i,j} \mathbf{F}_j^{(l-1)} \Theta^{(l-1)}) = \begin{cases} \frac{1}{|\tilde{\mathcal{N}}(v_i)|}, & \text{if } v_j \in \tilde{\mathcal{N}}(v_i), \\ 0, & \text{otherwise.} \end{cases}$$

A natural idea to speed up the computation while reducing the memory need for Eq. (7.7) is to approximate the expectation by Monte-Carlo sampling. Specifically, the expectation $\mathbb{E}[\mathcal{F}_{v_i}]$ can be estimated as:

$$\mathbb{E}[\mathcal{F}_{v_i}] \approx \hat{\mathcal{F}}_{v_i} = \frac{1}{|n^l(v_i)|} \sum_{v_j \in n^l(v_i)} \hat{\mathbf{A}}_{i,j} \mathbf{F}_j^{(l-1)} \Theta^{(l-1)}, \quad (7.8)$$

where $n^l(v_i) \subset \tilde{\mathcal{N}}(v_i)$ is a set of nodes sampled from \mathcal{V} for the l -th layer calculation for node v_i according to the following probability distribution:

$$p(v_j | v_i) = \begin{cases} \frac{1}{|\tilde{\mathcal{N}}(v_i)|}, & \text{if } v_j \in \tilde{\mathcal{N}}(v_i), \\ 0, & \text{otherwise.} \end{cases} \quad (7.9)$$

The estimator in Eq. (7.8) is unbiased as shown below:

$$\begin{aligned} \mathbb{E}[\hat{\mathcal{F}}_{v_i}] &= \mathbb{E} \left[\frac{1}{|n^l(v_i)|} \sum_{v_j \in n^l(v_i)} \hat{\mathbf{A}}_{i,j} \mathbf{F}_j^{(l-1)} \Theta^{(l-1)} \mathbb{1}\{v_j \in n^l(v_i)\} \right] \\ &= \mathbb{E} \left[\frac{1}{|n^l(v_i)|} \sum_{v_j \in \mathcal{V}} \hat{\mathbf{A}}_{i,j} \mathbf{F}_j^{(l-1)} \Theta^{(l-1)} \mathbb{1}\{v_j \in n^l(v_i)\} \right] \\ &= \frac{1}{|n^l(v_i)|} \sum_{v_j \in \mathcal{V}} \hat{\mathbf{A}}_{i,j} \mathbf{F}_j^{(l-1)} \Theta^{(l-1)} \mathbb{E}[\mathbb{1}\{v_j \in n^l(v_i)\}] \\ &= \frac{1}{|n^l(v_i)|} \sum_{v_j \in \mathcal{V}} \hat{\mathbf{A}}_{i,j} \mathbf{F}_j^{(l-1)} \Theta^{(l-1)} \frac{|n^l(v_i)|}{|\tilde{\mathcal{N}}(v_i)|} \\ &= \frac{1}{|\tilde{\mathcal{N}}(v_i)|} \sum_{v_j \in \mathcal{V}} \hat{\mathbf{A}}_{i,j} \mathbf{F}_j^{(l-1)} \Theta^{(l-1)} \\ &= \mathbb{E}[\mathcal{F}_{v_i}]. \end{aligned}$$

where $\mathbb{1}\{v_j \in n^l(v_i)\}$ is an indicator random variable, which takes value 1 if $v_j \in n^l(v_i)$ and 0 otherwise.

With Eq. (7.8), the node-wise aggregation process can be expressed as:

$$\mathbf{F}_i^{(l)} = \frac{|\tilde{\mathcal{N}}(v_i)|}{|n^l(v_i)|} \sum_{v_j \in n^l(v_i)} \hat{\mathbf{A}}_{i,j} \mathbf{F}_j^{(l-1)} \Theta^{(l-1)}. \quad (7.10)$$

The sampling process utilized in Eq. (7.10) is called *node-wise sampling*, as the node set $n^l(v_i)$ is sampled only for the node v_i and not shared with other nodes. Specifically, the GraphSAGE-Filter (see Section 5.3.2 for details on GraphSAGE-Filter) can be viewed as a node-wise sampling method due to the neighbor sampling process. Typically, for a specific graph filtering layer, the sampling size $|n^l(v_i)|$ is set to a fixed value $|n^l(v_i)| = m$ for all nodes. While different graph filtering layers can have different sampling sizes, for convenience, we assume that they all have the same sampling size m in this chapter.

Although the node-wise sampling methods can help control the size of the number of involved nodes in each layer to a fixed size m , it still suffers from the “neighborhood explosion” issue when m is large. In detail, following the same top-down perspective in Figure 7.1, the number of nodes involved to calculate the final representation $\mathbf{F}_i^{(L)}$ for node v_i is in the order of m^L , which increases exponentially as the number of layers L grows. The space and time complexity are $O(m^L \cdot d^2)$ and $O(|\mathcal{V}| \cdot m^L \cdot d^2)$, respectively. One way to alleviate this issue is to control the sampling size m to be a small number. However, a small m leads to a large variance in the estimation in Eq. (7.8), which is not desired.

A sampling method, which utilizes an extremely small sampling size m (as small as 2) while maintaining a reasonable variance is proposed in (Chen et al., 2018a). The idea is to keep a historical representation $\bar{\mathbf{F}}_i^{(l-1)}$ for each $\mathbf{F}_i^{(l-1)}$ for $l = 2, \dots, L$, and then utilize these historical representations during the calculation in Eq.(7.3). Each time when $\mathbf{F}_i^{(l)}$ is calculated, we update its corresponding historical representation $\bar{\mathbf{F}}_i^{(l)}$ with $\mathbf{F}_i^{(l)}$. The historical representations are expected to be similar to the real representations if the model parameters do not change too fast during the training process. We still use Monte-Carlo sampling to estimate Eq. (7.3). However, for those nodes that are not sampled to $n^l(v_i)$, we include their historical representations in the calculation. Formally, Eq. (7.3) can be decomposed into two terms as:

$$\mathbf{F}_i^{(l)} = \sum_{v_j \in \tilde{\mathcal{N}}(v_i)} \hat{\mathbf{A}}_{i,j} \Delta \mathbf{F}_j^{(l-1)} \Theta^{(l-1)} + \sum_{v_j \in \mathcal{N}(v_i)} \hat{\mathbf{A}}_{i,j} \bar{\mathbf{F}}_j^{(l-1)} \Theta^{(l-1)} \quad (7.11)$$

where

$$\Delta \mathbf{F}_j^{(l-1)} = \mathbf{F}_j^{(l-1)} - \bar{\mathbf{F}}_j^{(l-1)}.$$

The term $\Delta \mathbf{F}_j^{(l-1)}$ denotes the difference between the real up-to-date representation and the historical representation. Instead of using Monte-Carlo sampling to estimate the entire term in Eq. (7.3), only the difference is estimated as:

$$\sum_{v_j \in \tilde{\mathcal{N}}(v_i)} \hat{\mathbf{A}}_{i,j} \Delta \mathbf{F}_j^{(l-1)} \Theta^{(l-1)} \approx \frac{|\tilde{\mathcal{N}}(v_i)|}{|n^l(v_i)|} \sum_{v_j \in n^l(v_i)} \hat{\mathbf{A}}_{i,j} \Delta \mathbf{F}_j^{(l-1)} \Theta^{(l-1)}. \quad (7.12)$$

With Eq. (7.12), the aggregation process in Eq. (7.11) can be estimated as:

$$\mathbf{F}_i^{(l)} \approx \frac{|\tilde{\mathcal{N}}(v_i)|}{|n^l(v_i)|} \sum_{v_j \in n^l(v_i)} \hat{\mathbf{A}}_{i,j} \Delta \mathbf{F}_j^{(l-1)} \Theta^{(l-1)} + \sum_{v_j \in \tilde{\mathcal{N}}(v_i)} \hat{\mathbf{A}}_{i,j} \bar{\mathbf{F}}_j^{(l-1)} \Theta^{(l-1)}, \quad (7.13)$$

which is named as the control-variate (CV) estimator and utilized to update the node representations. Note that, the second term in the right hand side of Eq. (7.13) is calculated from stored historical node representations, which does not require the recursive calculation process and thus is computationally efficient. The CV-estimator is unbiased as the estimation in Eq. (7.12) is unbiased. The variance of Eq.(7.13) is smaller than that of Eq. (7.10) as $\Delta \mathbf{F}_i^{(l-1)}$ is much smaller than $\mathbf{F}_i^{(l-1)}$. However, the reduced variance does not come for free. While the time complexity of this process remains $O(m^L \cdot d^2)$ (m can be much smaller in the CV estimator) as the aggregation process described in Eq. (7.10), much more memory are required. In fact, to store the historical representations for all nodes involved in the process, $O(deg^L \cdot d)$ memory is required. It is the same as the SGD process without the node-wise sampling. Note that the space complexity is not dependent on the sampling size m ; hence, a smaller m cannot ensure the lower space complexity.

7.3 Layer-wise Sampling Methods

In the node-wise sampling methods, to calculate the final representation $\mathbf{F}_i^{(L)}$ for node v_i , the node set $n^L(v_i)$ is sampled from $\tilde{\mathcal{N}}(v_i)$ and $\mathbf{F}_j^{(L-1)}$ for $v_j \in n^L(v_i)$ is utilized during the calculation. Furthermore, to calculate $\mathbf{F}_j^{(L-1)}$ for each $v_j \in n^L(v_i)$, a node set $n^{(L-1)}(v_j)$ needs to be sampled. Specifically, let N^l denote all the nodes sampled for the calculation of the l -th layer, then N^l can be recursively defined from top to down as:

$$N^{l-1} = \cup_{v_j \in N^l} n^{l-1}(v_j), \quad \text{with } N^L = n^L(v_i). \quad l = L, \dots, 2, 1. \quad (7.14)$$

When the mini-batch SGD is adopted and the final representations of a batch \mathcal{B} of nodes need to be calculated, N^L can be defined as $N^L = \cup_{v_i \in \mathcal{B}} n^L(v_i)$. This recursive process in Eq. (7.14) makes N^l grows exponentially; thus, the

node-wise sampling methods still suffer from the “neighborhood explosion” issue. One way to solve the issue is to utilize the same set of sampled nodes to calculate all node representations in a specific layer. In other words, we allow $n^{l-1}(v_j) = n^{l-1}(v_k)$ for $\forall v_j, v_k \in N^l$; thus the size of $N^{(l-1)}$ remains constant as L increases. Then, we only need to sample once for each layer and this strategy is called as *layer-wise sampling*. However, it is impractical to make $n^{l-1}(v_j) = n^{l-1}(v_k)$ as they are sampled according to different node-specific distributions as described in Eq. (7.9). In detail, the set $n^{l-1}(v_j)$ is sampled from the neighborhood of the node v_j ; while $n^{l-1}(v_k)$ is sampled from the neighborhood of the node v_k .

Importance sampling is adopted by (Chen et al., 2018b; Huang et al., 2018) to design the layer-wise sampling methods. For the l -th layer, instead of using the node-specific distributions to sample the nodes, a shared distribution, which is defined over the entire node set \mathcal{V} , is utilized to sample a shared set of nodes. Then all the output node representations for this layer are calculated only based on these shared sampled nodes. Next, we introduce the details of two representative layer-wise sampling methods (Chen et al., 2018b; Huang et al., 2018). Since these two methods follow the similar design, we focus on the method in (Huang et al., 2018) and then briefly describe the one in (Chen et al., 2018b).

To be consistent with the original paper (Huang et al., 2018), we first reformulate the process from Eq. (7.6) to Eq.(7.9) as follows. The node-wise aggregation process in Eq.(7.3) can be rewritten as:

$$\mathbf{F}_i^{(l)} = D(v_i) \sum_{v_j \in \tilde{\mathcal{N}}(v_i)} \frac{\hat{\mathbf{A}}_{i,j}}{D(v_i)} \mathbf{F}_j^{(l-1)} \Theta^{(l-1)}, \quad (7.15)$$

where $D(v_i) = \sum_{v_j \in \tilde{\mathcal{N}}(v_i)} \hat{\mathbf{A}}_{i,j}$. Eq. (7.15) can be regarded as the following expectation form:

$$\mathbf{F}_i^{(l)} = D(v_i) \cdot \mathbb{E}[\mathcal{F}_{v_i}] \quad (7.16)$$

where \mathcal{F}_{v_i} is a discrete random variable as defined below:

$$p(\mathcal{F}_{v_i} = \mathbf{F}_j^{(l-1)} \Theta^{(l-1)}) = \begin{cases} \frac{\hat{\mathbf{A}}_{i,j}}{D(v_i)}, & \text{if } v_j \in \tilde{\mathcal{N}}(v_i), \\ 0, & \text{otherwise.} \end{cases}$$

Assume that $q^l(v_j)$ is a known distribution defined on the entire node set \mathcal{V} and $q^l(v_j) > 0, \forall v_j \in \mathcal{V}$. Instead of using Monte-Carlo sampling to estimate

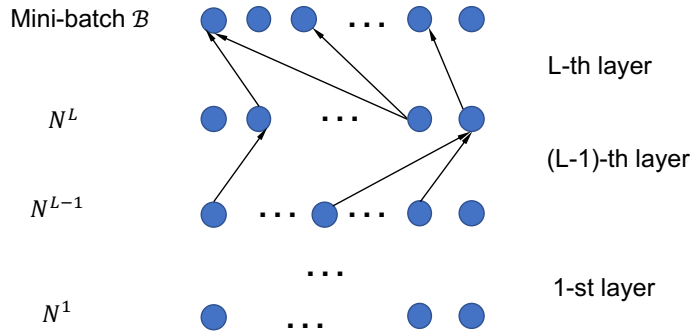

Figure 7.2 Layer-wise sampling

$\mathbb{E}[\mathcal{F}_{v_i}]$, we use importance sampling based on $q^l(v_j)$ as:

$$\mathbb{E}[\mathcal{F}_{v_i}] \approx \hat{\mathcal{F}}_{v_i} = \frac{1}{|N^l|} \sum_{v_j \in N^l} \frac{p(v_j|v_i)}{q^l(v_j)} \mathbf{F}_j^{(l-1)} \Theta^{(l-1)}, v_j \sim q^l(v_j) \forall v_j \in N^l, \quad (7.17)$$

where N^l denotes a set of nodes sampled according to the distribution $q^l(v_j)$ and $p(v_j|v_i) = \frac{\hat{\mathbf{A}}_{i,j}}{D(v_i)}$ if $v_j \in \tilde{\mathcal{N}}(v_i)$, otherwise $p(v_j|v_i) = 0$. The superscript l in $q^l(v_j)$ indicates that the distribution is utilized in the l -th layer to sample the node set N^l and different layers may use different sampling distributions. The set of nodes N^l is shared by all nodes (e.g., v_i) which need to calculate the representations (e.g., $\mathbf{F}_i^{(l)}$) in the l -th layer. With the importance sampling estimation for $\mathbb{E}[\mathcal{F}_{v_i}]$ in Eq. (7.17), the node-wise aggregation process (as described in Eq. (7.16)) with the layer-wise sampling strategy can then be described as:

$$\begin{aligned} \mathbf{F}_i^{(l)} &= D(v_i) \cdot \frac{1}{|N^l|} \sum_{v_j \in N^l} \frac{p(v_j|v_i)}{q(v_j)} \mathbf{F}_j^{(l-1)} \Theta^{(l-1)} \\ &= \frac{1}{|N^l|} \sum_{v_j \in N^l} \frac{\hat{\mathbf{A}}_{i,j}}{q^l(v_j)} \mathbf{F}_j^{(l-1)} \Theta^{(l-1)} \end{aligned} \quad (7.18)$$

where nodes in N^l are sampled from $q^l(v_j)$. Note that the distribution $q^l(v_j)$ is not dependent on the center node v_i and it is shared by all nodes. Before describing how to design the sampling distribution $q^l(v_j)$ appropriately, we first introduce the process to sample nodes and build the computational graph to calculate the final representations for all nodes in a sampled batch \mathcal{B} . As shown in Figure 7.2, from a top-down perspective, to calculate $\mathbf{F}_i^{(L)}$ for all

nodes $v_i \in \mathcal{B}$, a set of nodes N^L are sampled according to $q^L(v_j)$. The representations $\mathbf{F}_j^{(L-1)}$ of all $v_j \in N^L$ are used to calculate $\mathbf{F}_i^{(L)}$ for all nodes $v_i \in \mathcal{B}$ according to Eq. (7.18). To calculate $\mathbf{F}_j^{(L-1)}$ of $v_j \in N^L$, we need to sample N^{L-1} and aggregate information from them. This process goes to the bottom layer where N^1 is sampled and the input features $\mathbf{F}_j^{(0)}$ for $v_j \in N^1$ are utilized for the calculation. The memory required to compute the final representation $\mathbf{F}_i^{(L)}$ for each node $v_i \in \mathcal{B}$ according to Eq. (7.18), assuming $|N^l| = m$ for all layers, is $O(L \cdot m \cdot d)$. It is much smaller than that required by node-wise sampling based methods. Correspondingly, the time efficiency for each epoch is improved as fewer node representations are required to be computed during this process.

The importance sampling based estimator (IS-estimator) in Eq. (7.17) is unbiased and we want to find a distribution $q(v_j)$ such that the variance of Eq. (7.17) can be minimized. According to the derivations of importance sampling in (Owen, 2013), we conclude that:

Proposition 7.1 (Huang et al., 2018) *The variance of the estimator $\hat{\mathcal{F}}_{v_i}$ in Eq. (7.17) is given by:*

$$\text{Var}_q(\hat{\mathcal{F}}_{v_i}) = \frac{1}{|N^l|} \left[\frac{(p(v_j|v_i) \cdot |\mathbf{F}_j^{(l-1)} \Theta^{(l-1)}| - \mathbb{E}[\mathcal{F}_{v_i}] \cdot q(u_j))^2}{(q(v_j))^2} \right].$$

The optimal sampling distribution $q(v_j)$, which minimizes the above variance is given by:

$$q(v_j) = \frac{p(v_j|v_i) \cdot |\mathbf{F}_j^{(l-1)} \Theta^{(l-1)}|}{\sum_{v_k \in \mathcal{V}} p(v_k|v_i) \cdot |\mathbf{F}_k^{(l-1)} \Theta^{(l-1)}|}. \quad (7.19)$$

However, the optimal sampling distribution in Eq. (7.19) is not feasible as it is dependent on all node representations in the $(l-1)$ -th layer $\mathbf{F}^{(l-1)}$ but we are trying to use the sampling distribution to decide which of them to be calculated. Note that in (Chen et al., 2018b), the variance to be minimized is based on all the nodes in the same layer instead of a single node v_i as Proposition 7.1 and the optimal distribution takes a slightly different form but it is still dependent on $\mathbf{F}^{(l-1)}$.

Hence, two different approaches are proposed in (Chen et al., 2018b) and (Huang et al., 2018), respectively. In (Chen et al., 2018b), the dependence on $\mathbf{F}^{(l-1)}$ is directly discarded and a sampling distribution designed according to the opti-

mal probability distribution is adopted as $q(v_j)$:

$$q(v_j) = \frac{\|\hat{\mathbf{A}}_{:,j}\|^2}{\sum_{v_k \in \mathcal{V}} \|\hat{\mathbf{A}}_{:,k}\|^2}. \quad (7.20)$$

Note that the same $q(v_j)$ as described in Eq. (7.20) is used for all the layers. Hence, the superscript l is removed from $q^l(v_j)$. In (Huang et al., 2018), $\mathbf{F}_j^{(l-1)} \Theta^{(l-1)}$ in Eq. (7.19) is replaced by $\mathbf{F}_j^{(0)} \Theta_{in}$, where $\mathbf{F}_j^{(0)}$ denotes the input features of node v_j and Θ_{in} is a linear projection to be learned. Furthermore, the sampling distribution in Eq. (7.19) is optimal for a specific node v_i , but not ready for layer-wise sampling. To make the distribution applicable to layer-wise sampling, the following distribution, which summarizes computations over all nodes in N^{l+1} , is proposed in (Huang et al., 2018):

$$q^l(v_j) = \frac{\sum_{v_i \in N^{l+1}} p(v_j|v_i) \cdot |\mathbf{F}_j^{(0)} \Theta_{in}|}{\sum_{v_k \in \mathcal{V}} \sum_{v_i \in N^{l+1}} p(v_k|v_i) \cdot |\mathbf{F}_k^{(0)} \Theta_{in}|}. \quad (7.21)$$

Note that N^{l+1} denotes the nodes involved in the $(l + 1)$ -th layer, which is on the top of the l -th layer. Hence, the distribution $q^l(v_j)$ defined in Eq. (7.21) is dependent on the nodes in its top-layer. Furthermore the distribution is changing in an adaptive way during the training since the parameters Θ_{in} are kept updated. With these modifications to the optimal distribution in Eq. (7.19), the distribution in Eq. (7.21) is not guaranteed to lead to minimal variance. Therefore, the variance terms are directly included into the loss function to be explicitly minimized during the training process (Huang et al., 2018).

7.4 Subgraph-wise Sampling Methods

The layer-wise sampling based methods largely reduce the number of nodes involved in calculating final node representations and resolve the neighborhood explosion issue. However, the nature of layer-wise sampling methods is likely to cause another issue in the aggregation process from layer to layer. Specifically, it can be observed from Eq. (7.18) that the aggregation process to generate $\mathbf{F}_i^{(l)}$ is dependent on the term $\hat{\mathbf{A}}_{i,j}$ in each sampled node to be aggregated. This observation indicates that not all nodes in N^l are used to generate $\mathbf{F}_i^{(l)}$, but only those that have connections to node v_i are utilized. Then, if the connections between node v_i and the sampled nodes in N^l are too sparse, the representation $\mathbf{F}_i^{(l)}$ of node v_i may not be learned well. In an extreme case where there are no nodes in N^l connected to the node v_i , the representation of node v_i in

this layer is rendered to 0 according to Eq. (7.18). Hence, to improve the stability of the training process, we need to sample N^l with a reasonable number of connections to node v_i . In other words, we need to ensure that the connectivity between the sampled nodes in N^l and N^{l-1} is dense so that all nodes are likely to have some nodes to aggregate information from. Note that the layer-wise sampling methods described in Section 7.3 do not consider this when designing the layer-wise sampling distribution. To improve the connections between sampled nodes in consecutive layers, the sampling distributions for consecutive layers must be designed in a dependent way, which introduces significant difficulty. One way to ease the design is to use the same set of sampled nodes for all the layers, i.e., $N^l = N^{l-1}$ for $l = L \dots, 2$. Only one sample distribution needs to be designed so that more connections between the sampled nodes are encouraged. Furthermore, suppose the same set of nodes, denoted as \mathcal{V}_s , is adopted for all layers, then, the layer-wise aggregation in Eq. (7.18) is running the full neighborhood aggregations on the graph $\mathcal{G}_s = \{\mathcal{V}_s, \mathcal{E}_s\}$ that is induced on the sampled node sets \mathcal{V}_s . The induced graph \mathcal{G}_s is a subgraph of the original graph \mathcal{G} as $\mathcal{V}_s \subset \mathcal{V}$ and $\mathcal{E}_s \subset \mathcal{E}$. Instead of sampling \mathcal{V}_s , for each batch, we can directly sample a subgraph \mathcal{G}_s from \mathcal{G} and perform model training on the subgraph. The strategy to sample subgraphs for node representation and model training is called *subgraph-wise sampling*. There exist various subgraph-wise sampling based methods (Chiang et al., 2019; Zeng et al., 2019) with different focuses on the sampled graph \mathcal{G}_s .

In (Chiang et al., 2019), graph clustering methods such as METIS (Karypis and Kumar, 1998) and Graclus (Dhillon et al., 2007) are adopted to partition the graph \mathcal{G} into a set of subgraphs (clusters) $\{\mathcal{G}_s\}$ such that the number of links within each cluster is much more than that between clusters. To perform SGD, a subgraph is sampled from $\{\mathcal{G}_s\}$ each time and the gradient is estimated based on the following loss function:

$$\mathcal{L}_{\mathcal{G}_s} = \sum_{v_i \in \mathcal{V}_l \cap \mathcal{V}_s} \ell(f_{GNN}(\mathbf{A}_s, \mathbf{F}_s; \Theta)_i, y_i), \quad (7.22)$$

where $\mathbf{A}_s, \mathbf{F}_s$ denote the adjacency matrix and features for the sampled subgraph \mathcal{G}_s , respectively. The set $\mathcal{V}_l \cap \mathcal{V}_s$ consists of labeled nodes that are in \mathcal{V}_s . The memory required to perform one step of SGD based on the sampled subgraph \mathcal{G}_s is $O(|\mathcal{E}_s| + L \cdot |\mathcal{V}_s| \cdot d + L \cdot d^2)$.

In (Zeng et al., 2019), various node samplers are designed to sample a set of nodes \mathcal{V}_s where the subgraph \mathcal{G}_s is induced from. Specifically, an edge-based node sampler is designed to pair-wisely sample nodes that have high influence on each other and random-walk based sampler is designed to improve

the connectivity between the sampled nodes. We briefly describe these two samplers.

- **Edge-based Sampler:** Given a budget m , m edges are randomly sampled according to the following distribution:

$$p((u, v)) = \frac{\left(\frac{1}{d(u)+d(v)}\right)}{\sum_{(u',v') \in \mathcal{E}} \left(\frac{1}{d(u')+d(v')}\right)}, \quad (7.23)$$

where $d(v)$ denotes the degree of node v . The end nodes of the m sampled edges consist of the sampled nodes \mathcal{V}_s , which is used to induce the subgraph \mathcal{G}_s .

- **RW-based Sampler:** A set of r root nodes is uniformly sampled (with replacement) from the \mathcal{V} . Then starting from each sampled node, a random walk is generated. The nodes in the random walk consist of the final sampled node set \mathcal{V}_s , which is used to induce the subgraph \mathcal{G}_s .

Some normalization tricks are introduced in the aggregation process to make it less biased as:

$$\mathbf{F}_i^{(l)} = \sum_{v_j \in \mathcal{V}_s} \frac{\hat{\mathbf{A}}_{i,j}}{\alpha_{i,j}} \mathbf{F}_j^{(l-1)} \Theta^{(l-1)}, \quad (7.24)$$

where $\alpha_{i,j}$ can be estimated from the sampled subgraphs. In detail, a set of M subgraphs is sampled from the samplers and C_i and $C_{i,j}$ count the frequency of the node v_i and edge (v_i, v_j) appearing in the sampled M graphs, respectively. Then, $\alpha_{i,j}$ is estimated by $C_{i,j}/C_i$. Furthermore, the loss function for a mini-batch based on the sampled subgraph \mathcal{G}_s is also normalized as:

$$\mathcal{L}_{\mathcal{G}_s} = \sum_{v_i \in \mathcal{V}_i \cap \mathcal{V}_s} \frac{1}{\lambda_i} \ell(f_{GNN}(\mathbf{A}_s, \mathbf{F}_s; \Theta)_i, y_i), \quad (7.25)$$

where λ_i can be estimated as C_i/M . This normalization also makes the loss function less biased.

7.5 Conclusion

In this chapter, we discuss various sampling-based methods to improve the scalability of graph neural network models. We first introduce the “neighborhood explosion” issue, which makes stochastic gradient descent (SGD) methods impractical in training graph neural network models. Then, we present

three types of sampling methods, including node-wise, layer-wise, and subgraph-wise sampling. They aim to reduce the number of involved nodes during the forward pass of mini-batch SGD and improve scalability. For each group, we discuss their advantages and disadvantages and introduce representative algorithms.

7.6 Further Reading

In this chapter, we mainly discuss sampling-based methods to improve the scalability of the graph neural networks. Some of the introduced sampling techniques have been successfully applied to real-world applications. For example, the node-wise sampling based method GraphSage is adapted and applied to large scale graph based recommendation (Ying et al., 2018a); and the layer-wise sampling based method FastGCN (Chen et al., 2018b) is adopted to anti-money laundering in large scale bitcoin transaction network (Weber et al., 2019). Other efforts have been made to develop distributed frameworks for GNNs (Ma et al., 2018a; Wang et al., 2019e; Zhu et al., 2019c; Ma et al., 2019a). These distributed architectures for graph neural networks can handle large graphs with distributed data storage and parallel computation.

8

Graph Neural Networks on Complex Graphs

8.1 Introduction

In the earlier chapters, we have discussed graph neural network models focusing on simple graphs where the graphs are static and have only one type of nodes and one type of edges. However, graphs in many real-world applications are much more complicated. They typically have multiple types of nodes, edges, unique structures, and often are dynamic. As a consequence, these complex graphs present more intricate patterns that are beyond the capacity of the aforementioned graph neural network models on simple graphs. Thus, dedicated efforts are desired to design graph neural network models for complex graphs. These efforts can significantly impact the successful adoption and use of GNNs in a broader range of applications. In this chapter, using complex graphs introduced in Section 2.6 as examples, we discuss the methods to extend the graph neural network models to capture more sophisticated patterns. More specifically, we describe more advanced graph filters designed for complex graphs to capture their specific properties.

8.2 Heterogeneous Graph Neural Networks

Heterogeneous graphs, which consist of multiple types of nodes and edges as defined in Definition 2.35, are widely observed in real-world applications. For example, the relations between papers, authors, and venues can be described by a heterogeneous graph, as discussed in Section 2.6.1. Graph neural network models have been adapted to heterogeneous graphs (Zhang et al., 2018b; Wang et al., 2019i; Chen et al., 2019b). Meta-paths (see the definition of meta-path schema and meta-paths in Definition 4.5), which capture various relations between nodes with different semantics, are adopted to deal

with the heterogeneity in the heterogeneous graphs. In (Zhang et al., 2018b; Chen et al., 2019b), meta-paths are utilized to split a heterogeneous graph into several homogeneous graphs. Especially, meta-paths are treated as edges between nodes, and those meta-paths following the same meta-path schema are considered as the same type of edges. Each meta-path schema defines a simple homogeneous graph with meta-path instances following this schema as the edges. Graph filtering operations in Chapter 5 are applied to these simple homogeneous graphs to generate node representations capturing different local semantic information, which are then combined to generate the final node representations. Similarly, meta-paths are used to define meta-path based neighbors, which are treated differently during the graph filtering process in (Wang et al., 2019i). Specifically, given a meta-path schema ψ , a node v_j is defined as a ψ -neighbor for the node v_i , if the node v_j can be reached by node v_i through a meta-path following the schema ψ . The information aggregated from different types of meta-path based neighbors is combined through the attention mechanism to generate the updated node representations (Wang et al., 2019i). Next, we first formally define the meta-path based neighbors and then describe the graph filters designed for heterogeneous graphs.

Definition 8.1 (Meta-path based neighbors) Given a node v_i and a meta-path schema ψ in a heterogeneous graph, the ψ -neighbors of node v_i , denoted as $\mathcal{N}_\psi(v_i)$, consist of nodes that connect with node v_i through a meta-path following schema ψ .

The graph filters for heterogeneous graphs are designed in two steps: 1) aggregating information from ψ -neighbors for each $\psi \in \Psi$, where Ψ denotes the set of meta-path schemas adopted in the task; and 2) combining the information aggregated from each type of neighbors to generate the node representations. Specifically, for a node v_i , the graph filtering operation (for the l -th layer) updates its representation as:

$$\mathbf{z}_{\psi,i}^{(l)} = \sum_{v_j \in \mathcal{N}_\psi(v_i)} \alpha_{\psi,ij}^{(l-1)} \mathbf{F}_j^{(l-1)} \Theta_\psi^{(l-1)}$$

$$\mathbf{F}_i^{(l)} = \sum_{\psi \in \Psi} \beta_\psi^{(l)} \mathbf{z}_{\psi,i}^{(l)},$$

where $\mathbf{z}_{\psi,i}^{(l)}$ is the information aggregated from ψ -neighbors of node v_i , $\Theta_\psi^{(l-1)}$ is parameters specific to meta-path ψ based neighbors, and $\alpha_{\psi,ij}^{(l-1)}$ and $\beta_\psi^{(l)}$ are attention scores which can be learned as similar to the GAT-Filter introduced in Section 5.3.2. Specifically, $\alpha_{\psi,ij}^{(l-1)}$ is used to updates node representations of v_i and it indicates the contribution to v_i from its ψ -neighbor $v_j \in \mathcal{N}_\psi(v_i)$ in the

l -th layer. It is formally defined as:

$$\alpha_{\psi,ij}^{(l-1)} = \frac{\exp\left(\sigma\left(\mathbf{a}_{\psi}^{\top} \cdot \left[\mathbf{F}_i^{(l-1)} \Theta_{\psi}^{(l-1)}, \mathbf{F}_j^{(l-1)} \Theta_{\psi}^{(l-1)}\right]\right)\right)}{\sum_{v_k \in \mathcal{N}_{\psi}(v_i)} \exp\left(\sigma\left(\mathbf{a}_{\psi}^{\top} \cdot \left[\mathbf{F}_i^{(l-1)} \Theta_{\psi}^{(l-1)}, \mathbf{F}_k^{(l-1)} \Theta_{\psi}^{(l-1)}\right]\right)\right)},$$

where \mathbf{a}_{ψ} is a vector of parameters to be learned. Meanwhile, the attention score $\beta_{\psi}^{(l)}$ to combine information from different meta-path based neighbors is not specific for each node v_i but shared by all nodes in \mathcal{V} in their representation updates. $\beta_{\psi}^{(l)}$ indicates the contribution from the ψ -neighbors of v_i . It is formally defined as:

$$\beta_{\psi}^{(l)} = \frac{\exp\left(\frac{1}{|\mathcal{V}|} \sum_{i \in \mathcal{V}} \mathbf{q}^{\top} \cdot \tanh\left(\mathbf{z}_{\psi,i}^{(l)} \Theta_{\beta}^{(l)} + \mathbf{b}\right)\right)}{\sum_{\psi \in \Psi} \exp\left(\frac{1}{|\mathcal{V}|} \sum_{i \in \mathcal{V}} \mathbf{q}^{\top} \cdot \tanh\left(\mathbf{z}_{\psi,i}^{(l)} \Theta_{\beta}^{(l)} + \mathbf{b}\right)\right)},$$

where \mathbf{q} , $\Theta_{\beta}^{(l)}$ and \mathbf{b} are the parameters to be learned.

8.3 Bipartite Graph Neural Networks

Bipartite graphs are widely observed in real-world applications such as recommendations, where users and items are the two disjoint sets of nodes, and their interactions are the edges. In this section, we briefly introduce one general graph filter designed for bipartite graphs since we will present the advanced ones in Section 12.2.2, where we discuss the applications of graph neural networks in recommendations.

As introduced in Definition 2.36, there are two disjoint sets of nodes \mathcal{U} and \mathcal{V} , which can be of different types. There are only edges across the two sets while no edges exist within each set. To design the spatial based graph filters, the key idea is to aggregate information from neighboring nodes. In bipartite graphs, for any node $u_i \in \mathcal{U}$, its neighbors is a subset of \mathcal{V} , i.e., $\mathcal{N}(u_i) \subset \mathcal{V}$. Similarly, for a node $v_j \in \mathcal{V}$, its neighbors are from \mathcal{U} . Hence, two graph filtering operations are needed for these two sets of nodes, which can be described as:

$$\mathbf{F}_{u_i}^{(l)} = \frac{1}{|\mathcal{N}(u_i)|} \sum_{v_j \in \mathcal{N}(u_i)} \mathbf{F}_{v_j}^{(l-1)} \Theta_v^{(l-1)},$$

$$\mathbf{F}_{v_i}^{(l)} = \frac{1}{|\mathcal{N}(v_i)|} \sum_{u_j \in \mathcal{N}(v_i)} \mathbf{F}_{u_j}^{(l-1)} \Theta_u^{(l-1)},$$

where we use $\mathbf{F}_{u_i}^{(l)}$ to denote the node representation of u_i after the l -th layer, $\Theta_v^{(l-1)}$ and $\Theta_u^{(l-1)}$ are parameters to transform embedding from the node space \mathcal{V} to \mathcal{U} and \mathcal{U} to \mathcal{V} , respectively.

8.4 Multi-dimensional Graph Neural Networks

In many real-world graphs, multiple types of relations can simultaneously exist between a pair of nodes. These graphs with multiple types of relations can be modeled as multi-dimensional graphs, as introduced in Section 2.6.3. In multi-dimensional graphs, the same set of nodes is shared by all the dimensions, while each dimension has its structure. Hence, when designing graph filters for multi-dimensional graphs, it is necessary to consider both within- and across- dimension interactions. Specifically, the within-dimension interactions are through the connections between the nodes in the same dimension, while the across-dimension interactions are between the “copies” of the same node in different dimensions. In (Ma et al., 2019c), a graph filter, which captures both within- and across- information, is proposed. In detail, during the graph filtering process, for each node v_i , a set of representations of node v_i in all dimensions is first learned and then combined to generate an overall representation for node v_i . To update the representation of node v_i in the dimension d , we need to aggregate information from its neighbors in the same dimension and also the information about v_i in the other dimensions. Hence, we define two types of neighbors in multi-dimensional graphs: the within-dimension neighbors and the across-dimension neighbors. For a given node v_i in the dimension d , the within-dimension neighbors are those nodes that directly connect to the node v_i in the dimension d . In contrast, the across-dimension neighbors consist of the “copies” of the node v_i in other dimensions. The set of within-dimension neighbors of node v_i in dimension d is denoted as $\mathcal{N}_d(v_i)$. For example, in the multi-dimensional graph shown in Figure 8.1, for node 4, its within-dimension neighbors in the “red” dimension include the nodes 1, 2 and 5. Furthermore, the same node 4 is shared by all dimensions, which can be viewed as “copies” of the same node in different dimensions. These copies of node 4 implicitly connect to each other, and we call them as the across-dimension neighbors for node 4. As shown in Figure 8.1, the across-dimension neighbors for node 4 in the “red” dimension are the copies of node 4 in the “blue” and “green” dimensions. With these two types of neighbors, we can now describe the graph filtering operation (for node v_i in the l -th layer) designed for the multi-dimensional

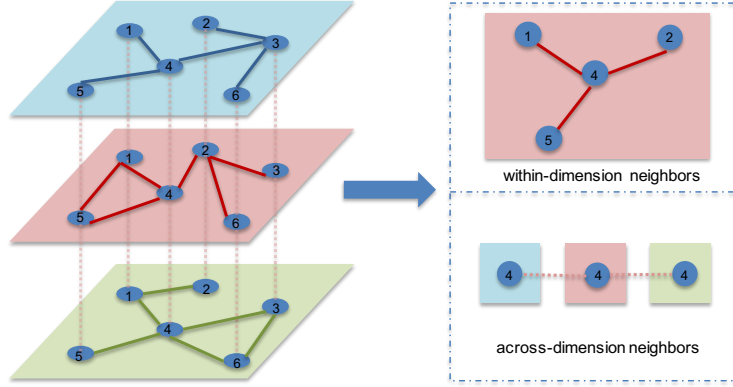

Figure 8.1 An illustrative example of two types of neighbors in the multi-dimensional graph

graph in (Ma et al., 2019c) as:

$$\mathbf{F}_{d,j}^{(l-1)} = \sigma(\mathbf{F}_j^{(l-1)} \Theta_d^{(l-1)}) \quad \text{for } v_j \in \mathcal{N}_d(v_i) \quad (8.1)$$

$$\mathbf{F}_{g,i}^{(l-1)} = \sigma(\mathbf{F}_i^{(l-1)} \Theta_g^{(l-1)}) \quad \text{for } g = 1, \dots, D \quad (8.2)$$

$$\mathbf{F}_{w,d,i}^{(l)} = \sum_{v_j \in \mathcal{N}_d(v_i)} \mathbf{F}_{d,j}^{(l-1)} \quad (8.3)$$

$$\mathbf{F}_{a,d,i}^{(l)} = \sum_{g=1}^D \beta_{g,d}^{(l-1)} \mathbf{F}_{g,i}^{(l-1)} \quad (8.4)$$

$$\mathbf{F}_i^{(l)} = \eta \mathbf{F}_{w,d,i}^{(l)} + (1 - \eta) \mathbf{F}_{a,d,i}^{(l)}. \quad (8.5)$$

We next explain the steps of graph filters as described from Eq. (8.1) to Eq. (8.5). In Eq. (8.1), the representations of within-dimension neighbors of node v_i from the previous layer (the $(l-1)$ -th layer) are mapped to dimension d by $\Theta_d^{(l-1)}$ and $\sigma(\cdot)$ is a non-linear activation function. Similarly, the representation of node v_i from the previous layer is projected to different dimensions where D is the total number of dimensions in the multi-dimension graph. The within-dimension aggregation is performed in Eq. (8.3), which generates the within-dimension representation for node v_i in the l -th layer. The across-dimension information aggregation is performed in Eq. (8.4), where $\beta_{g,d}^{(l-1)}$ is the attention score mod-

elting the impact of dimension g on dimension d , which is calculated as:

$$\beta_{g,d}^{(l-1)} = \frac{\text{tr}(\Theta_g^{(l-1)\top} \mathbf{W}^{(l-1)} \Theta_d^{(l-1)})}{\sum_{g=1}^D \text{tr}(\Theta_g^{(l-1)\top} \mathbf{W}^{(l-1)} \Theta_d^{(l-1)})},$$

where $\mathbf{W}^{(l-1)}$ is a parameter matrix to be learned. Finally, the within-dimension representation and the across-dimension representation of node v_i are combined in Eq. (8.5) to generate the updated v_i 's representation $\mathbf{F}_i^{(l)}$ after the l -th layer, where η is a hyperparameter balancing these two parts.

8.5 Signed Graph Neural Networks

In many real-world systems, relations can be both positive and negative. For instance, social media users not only have positive edges such as friends (e.g., Facebook and Slashdot), followers (e.g., Twitter), and trust (e.g., Epinions), but also can create negative edges such as foes (e.g., Slashdot), distrust (e.g., Epinions), blocked and unfriended users (e.g., Facebook and Twitter). These relations can be represented as graphs with both positive and negative edges. Signed graphs have become increasingly ubiquitous with the growing popularity of online social networks. A formal definition of signed graphs can be found in Section 2.6.4. The graph filters designed for simple graphs in Chapter 5 cannot be directly applied to signed graphs because of the existence of the negative edges. The negative edges carry very different or even opposite relations compared with the positive edges. Hence, to design graph filters for signed graphs, dedicated efforts are desired to properly handle the negative edges. A naive approach to address the negative edges is to split a signed graph into two separate unsigned graphs, each of which consists of only positive or negative edges. Then the graph filters in Section 5.3 can be separately applied to these two graphs, and the final node representations can be obtained by combining the representations from these two graphs. However, this approach ignores the complex interactions between the positive and negative edges suggested by social balance theories (Heider, 1946; Cartwright and Harary, 1956; Leskovec et al., 2010b), which can provide fruitful results if extracted properly (Kunegis et al., 2009; Leskovec et al., 2010a; Tang et al., 2016b). In (Derr et al., 2018), the balance theory is facilitated to model the relations between the positive and negative edges, based on which a specific graph filter is designed for signed graphs. Specifically, balanced and unbalanced paths are proposed based on the balance theory, which are then adopted to guide the aggregation process when designing the graph filters for signed graphs. Two representations for each node

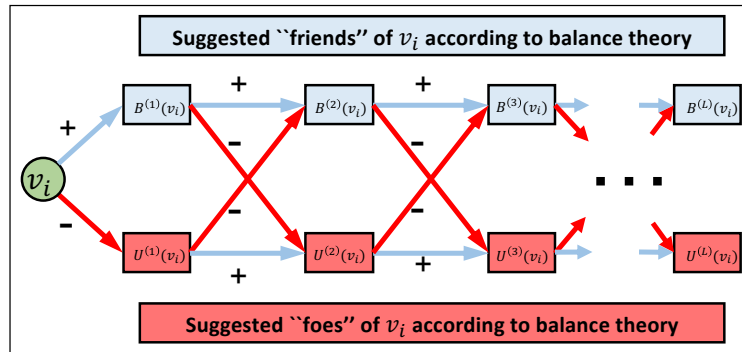

Figure 8.2 Balanced and unbalanced neighbors

are maintained, i.e., one catching the information aggregating from balanced paths and the other capturing information aggregating from unbalanced paths. Next, we first introduce the balanced and unbalanced paths, and then the graph filters designed for signed graphs. In general, balance theory (Heider, 1946; Cartwright and Harary, 1956) suggests that “the friend of my friend is my friend” and “the enemy of my friend is my enemy”. Therefore, the cycles in the graphs are classified as *balanced* or *unbalanced*. Specifically, a cycle with an even number of negative edges is considered as *balanced*, otherwise *unbalanced*. It is evident from numerous empirical studies that the majority of circles in real-world signed graphs are balanced (Tang et al., 2016b). Inspired by the definition of balanced cycles, we define a path consisting of an even number of negative edges as a *balanced path*. In contrast, an *unbalanced path* consists of an odd number of negative edges. Given the definition of the balanced path, we can see that a balanced path between node v_i and node v_j indicates a positive relation between them since a balanced cycle is expected according to balance theory and empirical studies. Similarly, an unbalanced path between nodes v_i and v_j indicates a negative relation between them. Given the definition of the balanced and unbalanced paths, we then define the balanced and unbalanced multi-hop neighbors. Nodes that can be reached by a balanced path of length $l-1$ from the node v_i are defined as the $(l-1)$ -hop balanced neighbors of the node v_i , denoted as $B^{(l-1)}(v_i)$. Similarly the set of unbalanced $(l-1)$ -hop neighbors can be defined and denoted as $U^{l-1}(v_i)$. Given the $(l-1)$ -hop balanced and unbalanced neighbors, we can conveniently introduce the l -hop balanced and unbalanced neighbors. As shown in Figure 8.2, adding a positive edge to a balanced path of length $l-1$ or adding a negative edge to an unbalanced path of length $l-1$ lead to balanced paths of length l . Unbalanced paths of length l

can be similarly defined. Formally, we can define the balanced neighbors and unbalanced neighbors of different hops (for $l > 2$) recursively as follows:

$$\begin{aligned} B^l(v_i) &= \{v_j | v_k \in B^{(l-1)}(v_i) \text{ and } v_j \in \mathcal{N}^+(v_k)\} \\ &\cup \{v_j | v_k \in U^{(l-1)}(v_i) \text{ and } v_j \in \mathcal{N}^-(v_k)\}, \\ U^l(v_i) &= \{v_j | v_k \in U^{(l-1)}(v_i) \text{ and } v_j \in \mathcal{N}^+(v_k)\} \\ &\cup \{v_j | v_k \in B^{(l-1)}(v_i) \text{ and } v_j \in \mathcal{N}^-(v_k)\}, \end{aligned}$$

where $\mathcal{N}^+(v_i)$ and $\mathcal{N}^-(v_i)$ denote 1-hop positive and 1-hop negative neighbors of node v_i and we have $B^1(v_i) = \mathcal{N}^+(v_i)$, $U^1(v_i) = \mathcal{N}^-(v_i)$, respectively.

When designing the graph filters for signed graphs, the information from the balanced neighbors and the unbalanced neighbors should be separately maintained, as they could carry very different information. In particular, the balanced neighbors can be regarded as potential “friends”, while the unbalanced neighbors can be viewed as potential “foes”. Hence, two types of representations are maintained to keep information aggregated from balanced and unbalanced neighbors, respectively. For a node v_i , $\mathbf{F}_i^{(B,l)}$ and $\mathbf{F}_i^{(U,l)}$ are used to denote its balanced representation and its unbalanced representation after l graph filtering layers, respectively. Specifically, the process of the graph filters in the l -th layer can be described as follows:

$$\mathbf{F}_i^{(B,l)} = \sigma \left(\left[\sum_{v_j \in \mathcal{N}^+(v_i)} \frac{\mathbf{F}_j^{(B,l-1)}}{|\mathcal{N}^+(v_i)|}, \sum_{v_k \in \mathcal{N}^-(v_i)} \frac{\mathbf{F}_k^{(U,l-1)}}{|\mathcal{N}^-(v_i)|}, \mathbf{F}_i^{(B,l-1)} \right] \Theta^{(B,l)} \right), \quad (8.6)$$

$$\mathbf{F}_i^{(U,l)} = \sigma \left(\left[\sum_{v_j \in \mathcal{N}^+(v_i)} \frac{\mathbf{F}_j^{(U,l-1)}}{|\mathcal{N}^+(v_i)|}, \sum_{v_k \in \mathcal{N}^-(v_i)} \frac{\mathbf{F}_k^{(B,l-1)}}{|\mathcal{N}^-(v_i)|}, \mathbf{F}_i^{(U,l-1)} \right] \Theta^{(U,l)} \right), \quad (8.7)$$

where $\Theta^{(B,l)}$ and $\Theta^{(U,l)}$ are parameters to learning. In Eq. (8.6), $\mathbf{F}_i^{(B,l)}$ is the concatenation of three types of information – (1) the aggregation of balanced representations (in the $(l-1)$ -th layer) from the positive neighbors of node v_i , i.e., $\sum_{v_j \in \mathcal{N}^+(v_i)} \frac{\mathbf{F}_j^{(B,l-1)}}{|\mathcal{N}^+(v_i)|}$; (2) the aggregation of unbalanced representations (in the $(l-1)$ -th layer) from the negative neighbors of node v_i , i.e., $\sum_{v_k \in \mathcal{N}^-(v_i)} \frac{\mathbf{F}_k^{(U,l-1)}}{|\mathcal{N}^-(v_i)|}$; and (3) the balanced representation of v_i in the $(l-1)$ layer. Similarly, $\mathbf{F}_i^{(U,l)}$ is generated by aggregating information from unbalanced paths in Eq. (8.7). After L graph filtering layers, the balanced and unbalanced representations for node v_i are combined to form the final representation for v_i as follows:

$$\mathbf{z}_i = [\mathbf{F}_i^{(B,L)}, \mathbf{F}_i^{(U,L)}],$$

where \mathbf{z}_i denotes the generated final representation for node v_i . In (Li et al., 2020b), attention mechanism is adopted to differentiate the importance of nodes

when performing the aggregation in Eq. (8.6) and Eq. (8.7). In detail, GAT-Filter is used to perform aggregation from the balanced/unbalanced neighbors in Eq. (8.6) and Eq. (8.7).

8.6 Hypergraph Neural Networks

In many real-world problems, relations among entities go beyond pairwise associations. For example, in a graph describing the relations between papers, a specific author can connect with more than two papers authored by him/her. Here the “author” can be viewed as a “hyperedge” connecting with multiple “papers” (nodes). Compared with edges in simple graphs, hyperedges can encode higher-order relations. The graphs with the hyperedges are named as hypergraphs. A formal definition of hypergraphs can be found in Section 2.6.5. The key to build graph filters for hypergraphs is to facilitate the high-order relations encoded by hyperedges. Specifically, pairwise relations are extracted from these hyperedges, which render the hypergraphs into a simple graph and graph filters designed for simple graphs as introduced in Section 5.3 can thus be applied (Feng et al., 2019b; Yadati et al., 2019). Next, we introduce some representative ways to extract the pairwise relations from the hyperedges. In (Feng et al., 2019b), pairwise relations between node pairs are estimated through the hyperedges. Two nodes are considered to be connected if they appear together in at least one hyperedge. If they appear in several hyperedges, the impact of these hyperedges is combined. An “adjacency matrix” describing the pairwise node relations can be formulated as:

$$\tilde{\mathbf{A}}_{hy} = \mathbf{D}_v^{-1/2} \mathbf{H} \mathbf{W} \mathbf{D}_e^{-1} \mathbf{H}^T \mathbf{D}_v^{-1/2}.$$

where the matrices \mathbf{D}_v , \mathbf{H} , \mathbf{W} , \mathbf{D}_e are defined in Definition 2.39. In detail, \mathbf{H} is the incidence matrix describing relations between nodes and hyperedges, \mathbf{W} is a diagonal matrix describing the weights on the hyperedges, \mathbf{D}_v and \mathbf{D}_e are the node and hyperedge degree matrices, respectively. Graph filters can then be applied to the simple graph defined by the matrix $\tilde{\mathbf{A}}_{hy}$. In (Feng et al., 2019b), the GCN-Filter is adopted that can be described as:

$$\mathbf{F}^{(l)} = \sigma(\tilde{\mathbf{A}}_{hy} \mathbf{F}^{(l-1)} \Theta^{(l-1)}),$$

where σ is a non-linear activation function.

In (Yadati et al., 2019), the method proposed in (Chan et al., 2018) is adopted to convert the hyperedges to pairwise relations. For each hyperedge e , which consists of a set of nodes, two nodes are chosen to be used to generate a simple

edge as:

$$(v_i, v_j) := \arg \max_{v_i, v_j \in e} \|\mathbf{h}(v_i) - \mathbf{h}(v_j)\|_2^2,$$

where $\mathbf{h}(v_i)$ can be regarded as some attributes (or some features) that are associated with node v_i . Specifically, in the setting of graph neural networks, for the l -th layer, the hidden representations learned from the previous layer $\mathbf{F}^{(l-1)}$ are the features to measure the relations. A weighted graph can then be constructed by adding all these extracted pairwise relations to the graph, and the weights for these edges are determined by their corresponding hyperedges. We then use $\mathbf{A}^{(l-1)}$ to denote the adjacency matrix describing these relations. The graph filter for the l -th layer can then be expressed as:

$$\mathbf{F}^{(l)} = \sigma(\tilde{\mathbf{A}}^{(l-1)} \mathbf{F}^{(l-1)} \Theta^{(l-1)}), \quad (8.8)$$

where $\tilde{\mathbf{A}}^{(l-1)}$ is a normalized version of $\mathbf{A}^{(l-1)}$ with the way introduced in the GCN-Filter in Section 5.3.2. Note that the adjacency matrix $\mathbf{A}^{(l-1)}$ for the graph filter is not fixed but adapted according to the hidden representations from the previous layer.

One major shortcoming for this definition is that only two nodes of each hyperedge are connected. It is likely to cause information loss for other nodes in the hyperedge. Furthermore, this might also lead to a very sparse graph. Hence, one approach to improve the adjacency matrix is proposed in (Chan and Liang, 2019). The chosen nodes are also connected to the remaining nodes in the corresponding hyperedge. Hence, each hyperedge results in $2|e| - 3$ edges, where $|e|$ denotes the number of nodes in the hyperedge e . The weight of each extracted edge is assigned as $1/(2|e| - 3)$. The adjacency matrix $\mathbf{A}^{(l-1)}$ is then built upon these edges, which can be utilized in the graph filtering process in Eq. (8.8).

8.7 Dynamic Graph Neural Networks

Dynamic graphs are constantly evolving; thus the existing graph neural network models are inapplicable as they are not able to capture the temporal information. In (Pareja et al., 2019), a graph neural network model, which has evolving weights across graph snapshots over time, named EvolveGCN, is proposed to deal with the discrete dynamic graphs (see the definition of discrete dynamic graphs in Section 2.6.6). For a discrete dynamic graph consisting of T snapshots, T graph neural network models with the same structure (i.e., a stack of several GNN-Filters) are learned. The model parameters for the first

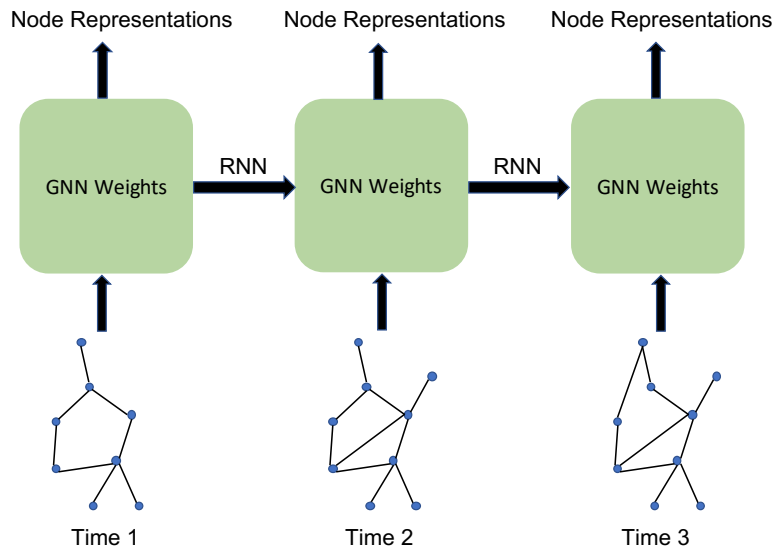

Figure 8.3 An illustration for EvolveGCN

graph neural network model are randomly initialized and learned during training, while the model parameters for the t -th GNN model is evolved from the model parameters for the $(t-1)$ -th model. As shown in Figure 8.3, the RNN architecture is adopted to update the model parameters. Both the LSTM and GRU variants of RNN as introduced in Section 3.4.2 can be used to update the model parameters. We take GRU as an example to illustrate the l -th graph filtering layer for the t -th graph snapshot as:

$$\Theta^{(l-1,t)} = \text{GRU}(\mathbf{F}^{(l-1,t)}, \Theta^{(l-1,t-1)}), \quad (8.9)$$

$$\mathbf{F}^{(l,t)} = \text{GNN-Filter}(\mathbf{A}^{(t)}, \mathbf{F}^{(l-1,t)}, \Theta^{(l-1,t)}), \quad (8.10)$$

where $\Theta^{(l-1,t)}$ and $\mathbf{F}^{(l,t)}$ denote the parameters and the output for the l -th graph filtering layer of the t -th GNN model, respectively. The matrix $\mathbf{A}^{(t)}$ is the adjacency matrix of the t -th graph snapshot. Note that the parameters $\Theta^{(l-1,t)}$ of the l -th layer for the t -th GNN model in Eq. (8.10) are evolved from $\Theta^{(l-1,t-1)}$ with GRU as shown in Eq. (8.9). The detailed architecture of GRU can be found in Section 3.4.3. General GNN-Filters can be adopted in Eq. (8.10), while the GCN-Filter is adopted by (Pareja et al., 2019).

8.8 Conclusion

This chapter discusses how the graph neural network models can be extended to complex graphs, including heterogeneous graphs, bipartite graphs, multi-dimensional graphs, signed graphs, hypergraphs, and dynamic graphs. For each type of complex graphs, we introduce representative graph filters that have been specifically designed to capture their properties and patterns.

8.9 Further Reading

While we have introduced representative graph neural networks for these complicated graphs, more works are constantly emerging. In (Zhang et al., 2019a), random walk is utilized to sample heterogeneous neighbors for designing graph neural networks for heterogeneous graphs. In (Sankar et al., 2018), a self-attention mechanism is utilized for discrete dynamic graphs. The attention mechanism is introduced for modeling hypergraph neural networks in (Bai et al., 2019). Graph neural networks have been designed for dynamic graphs in (Jiang et al., 2019; Ma et al., 2020b).

9

Beyond GNNs: More Deep Models on Graphs

9.1 Introduction

There are many traditional deep models, such as convolutional neural networks (CNNs), recurrent neural networks (RNNs), deep autoencoders, and generative adversarial networks (GANs). These models have been designed for different types of data. For example, CNNs can process regular grid-like data such as images, while RNNs can deal with sequential data such as text. They have also been designed in different settings. For instance, a large number of labeled data is needed to train good CNNs and RNNs (or the supervised setting), while autoencoders and GANs can extract complex patterns with only unlabeled data (or the unsupervised setting). These different architectures enable deep learning techniques to apply to many fields such as computer vision, natural language processing, data mining, and information retrieval. We have introduced various graph neural networks (GNNs) for simple and complex graphs in the previous chapters. However, these models have been developed only for certain graph tasks such as node classification and graph classification; and they often require labeled data for training. Thus, efforts have been made to adopt more deep architectures to graph-structured data. Autoencoders have been extended to graph-structured data for node representation learning (Wang et al., 2016; Kipf and Welling, 2016b; Pan et al., 2018). Deep generative models, such as variational autoencoder and generative adversarial networks, have also been adapted to graph-structured data for node representation learning (Kipf and Welling, 2016b; Pan et al., 2018; Wang et al., 2018a) and graph generation (Simonovsky and Komodakis, 2018; De Cao and Kipf, 2018). These deep graph models have facilitated a broader range of graph tasks under different settings beyond the capacity of GNNs; and have greatly advanced deep learning techniques on graphs. This chapter aims to cover more deep models on

graphs, including deep autoencoders, variational autoencoders, recurrent neural networks, and generative adversarial networks.

9.2 Autoencoders on Graphs

Autoencoders, which have been introduced in Section 3.5, can be regarded as unsupervised learning models to obtain compressed low-dimensional representations for input data samples. Autoencoders have been adopted to learn low-dimensional node representations (Wang et al., 2016; Kipf and Welling, 2016b; Pan et al., 2018). In (Wang et al., 2016), the neighborhood information of each node is utilized as the input to be reconstructed; hence the learned low-dimensional representation can preserve the structural information of the nodes. Both the encoder and decoder are modeled with feedforward neural networks as introduced in Section 3.5. In (Kipf and Welling, 2016b; Pan et al., 2018), the graph neural network model, which utilizes both the input node features and graph structure, is adopted as the encoder to encode node into low-dimensional representations. These encoded node representations are then employed to reconstruct the graph structural information. Next, we briefly introduce these two types of graph autoencoders for learning low-dimensional node representations.

In (Wang et al., 2016), for each node $v_i \in \mathcal{V}$, its corresponding row in the adjacency matrix of the graph $\mathbf{a}_i = \mathbf{A}_i$ is served as the input of the encoder to obtain its low-dimensional representation as:

$$\mathbf{z}_i = f_{enc}(\mathbf{a}_i; \Theta_{enc}),$$

where f_{enc} is the encoder, which is modeled with a feedforward neural network parameterized by Θ_{enc} . Then \mathbf{z}_i is utilized as the input to the decoder, which aims to reconstruct \mathbf{a}_i as:

$$\tilde{\mathbf{a}}_i = f_{dec}(\mathbf{z}_i; \Theta_{dec}),$$

where f_{dec} is the decoder and Θ_{dec} denotes its parameters. The reconstruction loss can thus be built by constraining $\tilde{\mathbf{a}}_i$ to be similar to \mathbf{a}_i for all nodes in \mathcal{V} as:

$$\mathcal{L}_{enc} = \sum_{v_i \in \mathcal{V}} \|\mathbf{a}_i - \tilde{\mathbf{a}}_i\|_2^2.$$

Minimizing the above reconstruction loss can “compress” the neighborhood information into the low-dimensional representation \mathbf{z}_i . The pairwise similarity between the neighborhood of nodes (i.e. the similarity between the input)

is not explicitly be captured. However, as the autoencoder (the parameters) is shared by all the nodes, the encoder is expected to map those nodes who have similar inputs to similar node representations, which implicitly preserves the similarity. The above reconstruction loss might be problematic due to the inherent sparsity of the adjacency matrix \mathbf{A} . A large portion of the elements in \mathbf{a}_i is 0, which might lead the optimization process to easily overfit to reconstructing the 0 elements. To solve this issue, more penalty is imposed to the reconstruction error of the non-zero elements by modifying the reconstruction loss as:

$$\mathcal{L}_{enc} = \sum_{v_i \in \mathcal{V}} \|(\mathbf{a}_i - \tilde{\mathbf{a}}_i) \odot \mathbf{b}_i\|_2^2,$$

where \odot denotes the Hadamard product, $\mathbf{b}_i = \{b_{i,j}\}_{j=1}^{|\mathcal{V}|}$ with $b_{i,j} = 1$ when $A_{i,j} = 0$ and $b_{i,j} = \beta > 1$ when $A_{i,j} \neq 0$. β is a hyperparameter to be tuned. Furthermore, to directly enforce connected nodes to have similar low-dimensional representations, a regularization loss is introduced as:

$$\mathcal{L}_{con} = \sum_{v_i, v_j \in \mathcal{V}} \mathbf{A}_{i,j} \cdot \|\mathbf{z}_i - \mathbf{z}_j\|_2^2.$$

Finally, regularization loss on the parameters of encoder and decoder is also included in the objective, which leads to the following loss to be minimized:

$$\mathcal{L} = \mathcal{L}_{enc} + \lambda \cdot \mathcal{L}_{con} + \eta \cdot \mathcal{L}_{reg},$$

where \mathcal{L}_{reg} denotes the regularization on the parameters, which can be expressed as:

$$\mathcal{L}_{reg} = \|\Theta_{enc}\|_2^2 + \|\Theta_{dec}\|_2^2. \quad (9.1)$$

The graph autoencoder model introduced above can only utilize the graph structure but not be able to incorporate node features when they are available. In (Kipf and Welling, 2016b), the graph neural network model is adopted as the encoder, which utilizes both the graph structural information and node features. Specifically, the encoder is modeled as:

$$\mathbf{Z} = f_{GNN}(\mathbf{A}, \mathbf{X}; \Theta_{GNN}),$$

where f_{GNN} is the encoder which is a graph neural network model. In (Kipf and Welling, 2016b), the GCN-Filter is adopted to build the encoder. The decoder is to reconstruct the graph, which includes the adjacency matrix \mathbf{A} and the attribute matrix \mathbf{X} . In (Kipf and Welling, 2016b), only the adjacency matrix \mathbf{A} is used as the target for reconstruction. Specifically, the adjacency matrix can

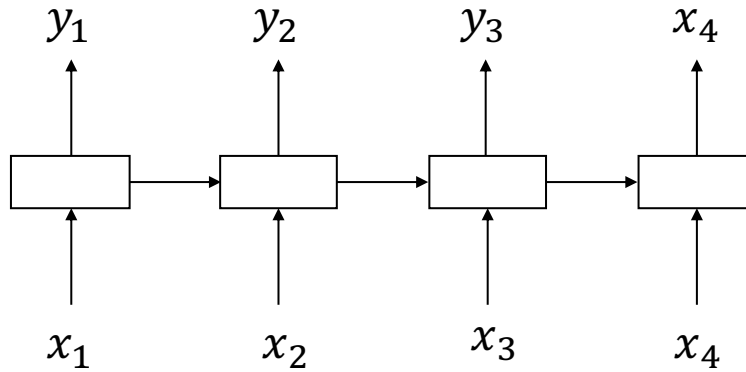

Figure 9.1 A illustrative sequence

be reconstructed from the encoded representations \mathbf{Z} as:

$$\hat{\mathbf{A}} = \sigma(\mathbf{Z}\mathbf{Z}^T),$$

where $\sigma(\cdot)$ is the sigmoid function. The low-dimensional representations \mathbf{Z} can be learned by minimizing the reconstruction error between $\hat{\mathbf{A}}$ and \mathbf{A} . The objective can be modeled as:

$$-\sum_{v_i, v_j \in \mathcal{V}} (\mathbf{A}_{i,j} \log \hat{\mathbf{A}}_{i,j} + (1 - \mathbf{A}_{i,j}) \log (1 - \hat{\mathbf{A}}_{i,j})),$$

which can be viewed as the cross-entropy loss between \mathbf{A} and $\hat{\mathbf{A}}$.

9.3 Recurrent Neural Networks on Graphs

Recurrent neural networks in Section 3.4 have been originally designed to deal with sequential data and have been generalized to learning representations for graph-structured data in recent years. In (Tai et al., 2015), Tree-LSTM is introduced to generalize the LSTM model to tree-structured data. A tree can be regarded as a special graph, which does not have any loops. In (Liang et al., 2016), Graph-LSTM is proposed to further extend the Tree-LSTM to generic graphs. In this section, we first introduce the Tree-LSTM and then discuss Graph-LSTM.

As shown in Figure 9.1, a sequence can be regarded as a specific tree where each node (except for the first one) has only a single child, i.e., its previous node. The information flows from the first node to the last node in the sequence.

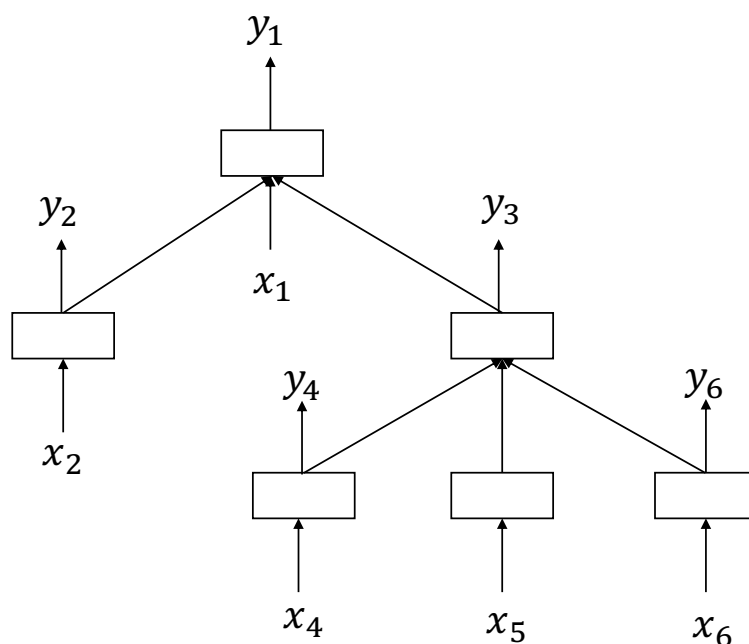

Figure 9.2 A illustrative tree

Hence, as introduced in Section 3.4.2 and illustrated in Figure 3.13, the LSTM model composes the hidden state of a given node in a sequence by using the input at this node and also the hidden state from its previous node. However, in comparison, as shown in Figure 9.2, in a tree, a node can have an arbitrary number of child nodes. In a tree, the information is assumed to always flow from the child nodes to the parent node. Hence, when composing the hidden state for a node, we need to utilize its input and the hidden states of its child nodes. Based on this intuition, the Tree-LSTM model is proposed to deal with tree-structured data. To introduce the Tree-LSTM model, we follow the same notations as those in Section 3.4.2. Specifically, for node v_k in the tree, we use $\mathbf{x}^{(k)}$ as its input, $\mathbf{h}^{(k)}$ as its hidden state, $\mathbf{C}^{(k)}$ as its cell memory and $\mathcal{N}_c(v_k)$ as the set of its child nodes. Given a tree, the Tree-LSTM model composes the

hidden state of node v_k as:

$$\tilde{\mathbf{h}}^{(k)} = \sum_{v_j \in \mathcal{N}_c(v_k)} \mathbf{h}^{(j)} \quad (9.2)$$

$$\mathbf{f}_{kj} = \sigma(\mathbf{W}_f \cdot \mathbf{x}^{(k)} + \mathbf{U}_f \cdot \mathbf{h}^{(j)} + \mathbf{b}_f) \quad \text{for } v_j \in \mathcal{N}_c(v_k) \quad (9.3)$$

$$\mathbf{i}_k = \sigma(\mathbf{W}_i \cdot \mathbf{x}^{(k)} + \mathbf{U}_i \cdot \tilde{\mathbf{h}}^{(k)} + \mathbf{b}_i) \quad (9.4)$$

$$\mathbf{o}_k = \sigma(\mathbf{W}_o \cdot \mathbf{x}^{(k)} + \mathbf{U}_o \cdot \tilde{\mathbf{h}}^{(k)} + \mathbf{b}_o) \quad (9.5)$$

$$\tilde{\mathbf{C}}^{(k)} = \tanh(\mathbf{W}_c \cdot \mathbf{x}^{(k)} + \mathbf{U}_c \cdot \tilde{\mathbf{h}}^{(k)} + \mathbf{b}_c) \quad (9.6)$$

$$\mathbf{C}^{(k)} = \mathbf{i}_k \odot \tilde{\mathbf{C}}^{(k)} + \sum_{v_j \in \mathcal{N}_c(v_k)} \mathbf{f}_{kj} \odot \mathbf{C}^{(j)} \quad (9.7)$$

$$\mathbf{h}^{(k)} = \mathbf{o}_k \odot \tanh(\mathbf{C}^{(k)}). \quad (9.8)$$

We next briefly describe the operation procedure of the Tree-LSTM model. The hidden states of the child nodes of v_k are aggregated to generate $\tilde{\mathbf{h}}^{(k)}$ as shown in Eq. (9.2). The aggregated hidden state $\tilde{\mathbf{h}}^{(k)}$ is utilized to generate the input gate, output gate and candidate cell memory in Eq. (9.4), Eq. (9.5) and Eq. (9.6), respectively. In Eq. (9.3), for each child $v_j \in \mathcal{N}_c(v_k)$, a corresponding forget gate is generated to control the information flow from this child node to v_k , when updating the memory cell for v_k in Eq. (9.7). Finally, in Eq. (9.8), the hidden state for node v_k is updated.

Unlike trees, there are often loops in generic graphs. Hence, there is no natural ordering for nodes in the generic graphs as that in trees. Breadth-First Search (BFS) and Depth-First Search (DFS) are the possible ways to define an ordering for the nodes as proposed in (Liang et al., 2016). Furthermore, the ordering of nodes can also be defined according to the specific application at hand. After obtaining an ordering for the nodes, we can use similar operations, as shown from Eq. (9.2) to Eq. (9.8) to update the hidden state and cells for these nodes following the obtained ordering. The major difference is that in undirected graphs, Eq. (9.2) aggregates hidden states from all neighbors $\mathcal{N}(v_k)$ of node v_k , while Tree-LSTM in Eq. (9.2) only aggregates information from the child nodes of v_k . Furthermore, the hidden states of some nodes in neighbors $\mathcal{N}(v_k)$ may not have been updated. In this case, the pre-updated hidden states are utilized in the aggregation process.

9.4 Variational Autoencoders on Graphs

Variational Autoencoder (VAE) is a kind of generative models, which aims to model the probability distribution of a given dataset $\mathcal{X} = \{\mathbf{x}_1, \dots, \mathbf{x}_N\}$. It is also

a latent variable model, which generates samples from latent variables. Given a latent variable \mathbf{z} sampled from a standard normal distribution $p(\mathbf{z})$, we want to learn a latent model, which can generate similar samples as these in the given data with the following probability:

$$p(\mathbf{x}|\mathbf{z}; \Theta) = \mathcal{N}(\mathbf{x}|f(\mathbf{z}; \Theta), \sigma^2 \cdot \mathbf{I}), \quad (9.9)$$

where $\mathcal{N}(\cdot|f(\mathbf{z}; \Theta), \sigma^2 \cdot \mathbf{I})$ denotes a Gaussian distribution with $f(\mathbf{z}; \Theta)$, $\sigma^2 \cdot \mathbf{I}$ as mean and covariance matrix respectively; Θ is the parameter to be learned and \mathbf{x} is a generated sample in the same domain as the given data. For example, if the input data samples are images, we want to generate images as well. $f(\mathbf{z}; \Theta)$ is a deterministic function, which maps the latent variable \mathbf{z} to the mean of the probability of the generative model in Eq. (9.9). Note that, in practice, the probability distribution of the generated samples is not necessary to be Gaussian but can be other distributions according to specific applications. Here, for convenience, we use Gaussian distribution as an example, which is adopted when generating images in computer vision tasks. To ensure that the generative model in Eq. (9.9) is representative of the given data \mathcal{X} , we need to maximize the following log likelihood for each sample \mathbf{x}_i in \mathcal{X} :

$$\log p(\mathbf{x}_i) = \log \int p(\mathbf{x}_i|\mathbf{z}; \Theta)p(\mathbf{z})d\mathbf{z} \text{ for } \mathbf{x}_i \in \mathcal{X}. \quad (9.10)$$

However, the integral in Eq. (9.10) is intractable. Furthermore, the true posterior $p(\mathbf{z}|\mathbf{x}; \Theta)$ is also intractable, which hinders the possibility of using the EM algorithm. To remedy this issue, an inference model $q(\mathbf{z}|\mathbf{x}; \Phi)$ parameterized with Φ , which is an approximation of the intractable true posterior $p(\mathbf{z}|\mathbf{x}; \Theta)$, is introduced (Kingma and Welling, 2013). Usually, $q(\mathbf{z}|\mathbf{x}; \Phi)$ is modeled as a Gaussian distribution $q(\mathbf{z}|\mathbf{x}; \Phi) = \mathcal{N}(\mu(\mathbf{x}; \Phi), \Sigma(\mathbf{x}; \Phi))$, where the mean and covariance matrix are learned through some deterministic function parameterized with Φ . Then, the log-likelihood in Eq. (9.10) can be rewritten as:

$$\log p(\mathbf{x}_i) = D_{KL}(q(\mathbf{z}|\mathbf{x}_i; \Phi)||p(\mathbf{z}|\mathbf{x}_i; \Theta)) + \mathcal{L}(\Theta, \Phi; \mathbf{x}_i),$$

where $\mathcal{L}(\Theta, \Phi; \mathbf{x}_i)$ is called the variational lower bound of the log-likelihood of \mathbf{x}_i as the KL divergence of the approximate and the true posterior (the first term on the right hand side) is non-negative. Specifically, the variational lower bound can be written as:

$$\mathcal{L}(\Theta, \Phi; \mathbf{x}_i) = \underbrace{\mathbb{E}_{q(\mathbf{z}|\mathbf{x}_i; \Phi)} [\log p(\mathbf{x}_i|\mathbf{z}; \Theta)]}_{\text{reconstruction}} - \underbrace{D_{KL}(q(\mathbf{z}|\mathbf{x}_i; \Phi)||p(\mathbf{z}))}_{\text{regularization}}. \quad (9.11)$$

Instead of maximizing the log-likelihood in Eq. (9.10) for samples in \mathcal{X} , we

aim to differentiate and maximize the variational lower bound in Eq. (9.11) with respect to both Θ and Φ . Note that minimizing the negation of the variational lower bound $-\mathcal{L}(\Theta, \Phi; \mathbf{x}_i)$ resembles the process of the classic autoencoder as introduced in Section 3.5, which gives the name “Variational Autoencoder” to the model. Specifically, the first term on the right hand side of Eq. (9.11) can be regarded as the reconstruction process, where $q(\mathbf{z}|\mathbf{x}_i; \Phi)$ is the encoder (the inference model) and $p(\mathbf{x}_i|\mathbf{z}; \Theta)$ is the decoder (the generative model). Different from the classical autoencoder, where the encoder maps a given input to a representation, this encoder $q(\mathbf{z}|\mathbf{x}_i; \Phi)$ maps an input \mathbf{x}_i into a latent Gaussian distribution. Maximizing the first term on the right hand side of Eq. (9.11) can be viewed as minimizing the distance between the input \mathbf{x}_i and the decoded mean $f(\mathbf{z}; \Theta)$ of $p(\mathbf{x}_i|\mathbf{z}; \Theta)$. Meanwhile, the second term on the right hand side of Eq. (9.11) can be regarded as a regularization term, which enforces the approximated posterior $q(\mathbf{z}|\mathbf{x}_i; \Phi)$ to be close to the prior distribution $p(\mathbf{z})$. After training, the generative model $p(\mathbf{x}_i|\mathbf{z}; \Theta)$ can be utilized to generate samples that are similar to the ones in the given data while the latent variable can be sampled from the standard Gaussian distribution $p(\mathbf{z})$.

9.4.1 Variational Autoencoders for Node Representation Learning

In (Kipf and Welling, 2016b), the variational autoencoder is adopted to learn node representations on graphs. The inference model is to encode each node into a multivariate Gaussian distribution and the joint distribution of all nodes are shown below:

$$q(\mathbf{Z}|\mathbf{X}, \mathbf{A}; \Phi) = \prod_{v_i \in \mathcal{V}} q(\mathbf{z}_i|\mathbf{X}, \mathbf{A}; \Phi)$$

$$\text{with } q(\mathbf{z}_i|\mathbf{X}, \mathbf{A}; \Phi) = \mathcal{N}(\mathbf{z}_i|\boldsymbol{\mu}_i, \text{diag}(\boldsymbol{\sigma}_i^2)), \quad (9.12)$$

where $\boldsymbol{\mu}_i$ and $\boldsymbol{\sigma}_i$ are the mean and variance learned through deterministic graph neural network models as follows:

$$\boldsymbol{\mu} = \text{GNN}(\mathbf{X}, \mathbf{A}; \Phi_\mu),$$

$$\log \boldsymbol{\sigma} = \text{GNN}(\mathbf{X}, \mathbf{A}; \Phi_\sigma),$$

where $\boldsymbol{\mu}$ and $\boldsymbol{\sigma}$ are matrices with $\boldsymbol{\mu}_i$ and $\boldsymbol{\sigma}_i$ indicating their i -th rows, respectively. The parameters Φ_μ and Φ_σ can be summarized as Φ in Eq. (9.12). Specifically, in (Kipf and Welling, 2016b), the GCN-Filter is adopted as the graph neural network model to build the inference model. The generative model, which is to generate (reconstruct) the adjacent matrix of the graph, is modeled

with the inner product between the latent variables \mathbf{Z} as follows:

$$p(\mathbf{A}|\mathbf{Z}) = \prod_{i=1}^N \prod_{j=1}^N p(\mathbf{A}_{i,j}|\mathbf{z}_i, \mathbf{z}_j),$$

with $p(\mathbf{A}_{i,j} = 1|\mathbf{z}_i, \mathbf{z}_j) = \sigma(\mathbf{z}_i^\top \mathbf{z}_j)$,

where $\mathbf{A}_{i,j}$ is the ij -th element of the adjacency matrix \mathbf{A} and $\sigma(\cdot)$ is the sigmoid function. Note that there are no parameters in the generative model. The variational parameters in the inference model are learned by optimizing the variational lower bound as shown below:

$$\mathcal{L} = \mathbb{E}_{q(\mathbf{Z}|\mathbf{X}, \mathbf{A}; \Phi)}[\log p(\mathbf{A}|\mathbf{Z})] - \text{KL}[q(\mathbf{Z}|\mathbf{X}, \mathbf{A}; \Phi)||p(\mathbf{Z})],$$

where $p(\mathbf{Z}) = \prod_i p(\mathbf{z}_i) = \prod_i \mathcal{N}(\mathbf{z}_i|0, \mathbf{I})$ is a Gaussian prior enforced to the latent variables \mathbf{Z} .

9.4.2 Variational Autoencoders for Graph Generation

In the task of graph generation, we are given a set of graph $\{\mathcal{G}_i\}$ and try to generate graphs that are similar to them. Variational Autoencoder has been adopted to generate small graphs such as molecular graphs (Simonovsky and Komodakis, 2018). Specifically, given a graph \mathcal{G} , the inference model $q(\mathbf{z}|\mathcal{G}; \Phi)$ aims to map it to a latent distribution. Meanwhile, the decoder can be represented by a generative model $p(\mathcal{G}|\mathbf{z}; \Theta)$. Both Φ and Θ are parameters, which can be learned by optimizing the following variational lower bound of the log-likelihood $\log p(\mathcal{G}; \Theta)$ of \mathcal{G} :

$$\mathcal{L}(\Phi, \Theta; \mathcal{G}) = \mathbb{E}_{q(\mathbf{z}|\mathcal{G}; \Phi)}[\log p(\mathcal{G}|\mathbf{z}; \Theta)] - D_{\text{KL}}[q(\mathbf{z}|\mathcal{G}; \Phi)||p(\mathbf{z})], \quad (9.13)$$

where $p(\mathbf{z}) = \mathcal{N}(\mathbf{0}, \mathbf{I})$ is a Gaussian prior on \mathbf{z} . Next, we describe the details about the encoder (inference model) $q(\mathbf{z}|\mathcal{G}; \Phi)$, the decoder (generative model) $p(\mathcal{G}|\mathbf{z}; \Theta)$ and finally discuss how to evaluate $\mathbb{E}_{q(\mathbf{z}|\mathcal{G}; \Phi)}[\log p(\mathcal{G}|\mathbf{z}; \Theta)]$.

Encoder: The Inference Model

In (Simonovsky and Komodakis, 2018), the goal is to generate small graphs with few nodes. For example, molecular graphs are usually quite small. Furthermore, these graphs are assumed to be associated with node and edge attributes. In the case of molecular graphs, the node and edge attributes indicate the type of nodes and edges, which are encoded as 1-hot vectors. Specifically, a graph $\mathcal{G} = \{\mathbf{A}, \mathbf{F}, \mathbf{E}\}$ can be represented by its adjacency matrix $\mathbf{A} \in \{0, 1\}^{N \times N}$, node attributes $\mathbf{F} \in \{0, 1\}^{N \times t_n}$ and also edge attributes $\mathbf{E} \in \{0, 1\}^{N \times N \times t_e}$. Usually,

in molecular graphs, the number of nodes N is in the order of tens. \mathbf{F} is the matrix indicating the attribute (type) of each node, where t_n is the number of node types. Specifically, the i -th row of \mathbf{F} is a one-hot vector indicating the type of i -th node. Similarly, \mathbf{E} is a tensor indicating the types of edges where t_e is the number of edge types. Note that, the graph is typically not complete and thus, we do not have $N \times N$ edges. Hence, in \mathbf{E} , the “one-hot” vectors corresponding to the non-existing edges are $\mathbf{0}$ vectors. To fully utilize the given graph information, the graph neural network model with pooling layers is utilized to model the encoder as:

$$q(\mathbf{z}|\mathcal{G}; \Phi) = \mathcal{N}(\boldsymbol{\mu}, \boldsymbol{\sigma}^2),$$

$$\boldsymbol{\mu} = \text{pool}(\text{GNN}_\mu(\mathcal{G})); \quad \log \boldsymbol{\sigma} = \text{pool}(\text{GNN}_\sigma(\mathcal{G})),$$

where the mean and variance are learned by graph neural network models. In detail, the ECC-Filter as introduced in Section 5.3.2 is utilized to build the graph neural network model to learn the node representations while the gated global pooling introduced in Section 5.4.1 is adopted to pool the node representations to generate the graph representation.

Decoder: The Generative Model

The generative model aims to generate a graph \mathcal{G} given a latent representation \mathbf{z} . In other words, it is to generate the three matrices \mathbf{A} , \mathbf{E} , and \mathbf{F} . In (Simonovsky and Komodakis, 2018), the size of the graphs to be generated is limited to a small number k . In detail, the generative model is asked to output a probabilistic fully connected graph with k nodes $\tilde{\mathcal{G}} = \{\tilde{\mathbf{A}}, \tilde{\mathbf{E}}, \tilde{\mathbf{F}}\}$. In this probabilistic graph, the existence of nodes and edges are modeled as Bernoulli variables while the types of nodes and edges are modeled as Multinomial variables. Specifically, the predicted fully connected adjacency matrix $\tilde{\mathbf{A}} \in [0, 1]^{k \times k}$ contains both the node existence probabilities at the diagonal elements $\tilde{\mathbf{A}}_{i,i}$ and the edge existence probabilities at the off-diagonal elements $\tilde{\mathbf{A}}_{i,j}$. The edge type probabilities are contained in the tensor $\tilde{\mathbf{E}} \in \mathbb{R}^{k \times k \times t_e}$. The node type probabilities are expressed in the matrix $\tilde{\mathbf{F}} \in \mathbb{R}^{k \times t_n}$. Different architectures can be used for modelling the generative model. In (Simonovsky and Komodakis, 2018), a simple feedforward network model, which takes the latent variable \mathbf{z} as input and outputs three matrices in its last layer, is adopted. Sigmoid function is applied to obtain $\tilde{\mathbf{A}}$, which demonstrates the probability of the existence of nodes and edges. Edge-wise and node-wise softmax functions are applied to obtain $\tilde{\mathbf{E}}$ and $\tilde{\mathbf{F}}$, respectively. Note that the obtained probabilistic graph $\tilde{\mathcal{G}}$ can be regarded as the generative model, which can be expressed as:

$$p(\mathcal{G}|\mathbf{z}; \Theta) = p(\tilde{\mathcal{G}}|\tilde{\mathcal{G}}),$$

where

$$\tilde{\mathcal{G}} = \text{MLP}(\mathbf{z}; \Theta).$$

The $\text{MLP}()$ denotes the feedforward network model.

Reconstruction Loss

To optimize Eq. (9.13), it is remained to evaluate $\mathbb{E}_{q(\mathbf{z}|\mathcal{G};\Theta)} [\log p(\mathcal{G}|\mathbf{z}; \Theta)]$, which can be regarded evaluating how close the input graph \mathcal{G} and the reconstructed probabilistic graph $\tilde{\mathcal{G}}$ are. Since there is no particular node ordering in graphs, comparing two graphs is difficult. In (Simonovsky and Komodakis, 2018), the max pooling matching algorithm (Cho et al., 2014b) is adopted to find correspondences $\mathbf{P} \in \{0, 1\}^{k \times N}$ between the input graph \mathcal{G} and the $\tilde{\mathcal{G}}$. It is based on the similarity between the nodes from the two graphs, where N denotes the number of nodes in \mathcal{G} and k is the number of nodes in $\tilde{\mathcal{G}}$. Specifically, $\mathbf{P}_{i,j} = 1$ only when the i -th node in $\tilde{\mathcal{G}}$ is aligned with the j -th node in the original graph \mathcal{G} , otherwise $\mathbf{P}_{i,j} = 0$. Given the alignment matrix \mathbf{P} , the information in the two graphs can be aligned to be comparable. In particular, the input adjacency matrix can be mapped to the predicted graph as $\mathbf{A}' = \mathbf{P}\mathbf{A}\mathbf{P}^T$, while the predicted node types and edge types can be mapped to the input graph as $\tilde{\mathbf{F}}' = \mathbf{P}^T\tilde{\mathbf{F}}$ and $\tilde{\mathbf{E}}'_{:,i,j} = \mathbf{P}^T\tilde{\mathbf{E}}_{:,i,j}\mathbf{P}$. Then, $\mathbb{E}_{q(\mathbf{z}|\mathcal{G};\Theta)} [\log p(\mathcal{G}|\mathbf{z}; \Theta)]$ is estimated with a single latent variable \mathbf{z} sampled from $q(\mathbf{z}|\mathcal{G})$ as follows:

$$\mathbb{E}_{q(\mathbf{z}|\mathcal{G};\Theta)} [\log p(\mathcal{G}|\mathbf{z}; \Theta)] \approx \log p(\mathcal{G}|\mathbf{z}; \Theta) = \log p(\mathbf{A}', \mathbf{E}, \mathbf{F}|\tilde{\mathbf{A}}, \tilde{\mathbf{E}}'\tilde{\mathbf{F}}'),$$

where $p(\mathbf{A}', \mathbf{E}, \mathbf{F}|\tilde{\mathbf{A}}, \tilde{\mathbf{E}}'\tilde{\mathbf{F}}')$ can be modeled as:

$$\begin{aligned} p(\mathbf{A}', \mathbf{E}, \mathbf{F}|\tilde{\mathbf{A}}, \tilde{\mathbf{E}}'\tilde{\mathbf{F}}') \\ = \lambda_A \log p(\mathbf{A}'|\tilde{\mathbf{A}}) + \lambda_E \log p(\mathbf{E}|\tilde{\mathbf{E}}') + \lambda_F \log p(\mathbf{F}|\tilde{\mathbf{F}}'), \end{aligned} \quad (9.14)$$

where λ_A , λ_E and λ_F are hyperparameters. Specifically, the three terms in Eq. (9.14) are the log-likelihood of the \mathbf{A}' , \mathbf{E} and \mathbf{F} , respectively, which can be modeled as the negation of the cross-entropy between \mathbf{A}' and $\tilde{\mathbf{A}}$; \mathbf{E} and $\tilde{\mathbf{E}}'$; \mathbf{E} and $\tilde{\mathbf{E}}'$, respectively. In detail, they can be formally stated as:

$$\begin{aligned} \log p(\mathbf{A}'|\tilde{\mathbf{A}}) &= \frac{1}{k} \sum_{i=1}^k [\mathbf{A}'_{i,i} \log \tilde{\mathbf{A}}_{i,i} + (1 - \mathbf{A}'_{i,i}) \log(1 - \tilde{\mathbf{A}}_{i,i})] \\ &\quad + \frac{1}{k(k-1)} \sum_{i \neq j}^k [\mathbf{A}'_{i,j} \log \tilde{\mathbf{A}}_{i,j} + (1 - \mathbf{A}'_{i,j}) \log(1 - \tilde{\mathbf{A}}_{i,j})], \\ \log p(\mathbf{E}|\tilde{\mathbf{E}}') &= \frac{1}{\|\mathbf{A}\|_1 - N} \sum_{i \neq j}^N \log(\mathbf{E}_{i,j}^\top; \tilde{\mathbf{E}}_{i,j:}), \\ \log p(\mathbf{F}|\tilde{\mathbf{F}}') &= \frac{1}{N} \sum_{i=1}^N \log(\mathbf{F}_{i,:}^\top; \tilde{\mathbf{F}}'_{i,:}). \end{aligned}$$

9.5 Generative Adversarial Networks on Graphs

The generative adversarial nets (GANs) are a framework to estimate the complex data distribution via an adversarial process where the generative model is pitted against an adversary: a discriminative model that learns to tell whether a sample is from the original data or generated by the generative model (Goodfellow et al., 2014a). In detail, the generative model $G(\mathbf{z}; \Theta)$ maps a noise variable \mathbf{z} sampled from a prior noise distribution $p(\mathbf{z})$ to the data space with Θ as its parameters. While, the discriminative model $D(\mathbf{x}; \Phi)$ is modeled as a binary classifier with the parameters Φ , which tells whether a given data sample \mathbf{x} is sampled from the data distribution $p_{data}(\mathbf{x})$ or generated by the generative model G . Specifically, $D(\mathbf{x}; \Phi)$ maps \mathbf{x} to a scalar indicating the probability that \mathbf{x} comes from the given data rather than being generated by the generative model. During the training procedure, the two models are competing against each other. The generative model tries to learn to generate fake samples that are good enough to fool the discriminator, while the discriminator tries to improve itself to identify the samples generated by the generative model as fake samples. The competition drives both models to improve themselves until the generated samples are indistinguishable from the real ones. This competition can be modeled as a two-player minimax game as:

$$\min_{\Theta} \max_{\Phi} \mathbb{E}_{\mathbf{x} \sim p_{data}(\mathbf{x})} [\log D(\mathbf{x}; \Phi)] + \mathbb{E}_{\mathbf{z} \sim p(\mathbf{z})} [\log(1 - D(G(\mathbf{z}; \Theta)))].$$

The parameters of the generative model and the discriminative model are optimized alternatively. In this section, we will use node representation learning and graph generation tasks as examples to describe how the GAN frameworks can be applied to graph-structured data.

9.5.1 Generative Adversarial Networks for Node Representation Learning

In (Wang et al., 2018a), the GAN framework is adapted for node representation learning. Given a node v_i , the generative model aims to approximate the distribution of its neighbors. It can be denoted as $p(v_j|v_i)$ that is defined over the entire set of nodes \mathcal{V} . The set of its real neighbors $\mathcal{N}(v_i)$ can be regarded as the observed samples drawn from $p(v_j|v_i)$. The generator, which is denoted as $G(v_j|v_i; \Theta)$, tries to generate (more precisely, select) the node that is most likely connected with node v_i from \mathcal{V} . $G(v_j|v_i; \Theta)$ can be regarded as the probability of sampling v_j as a fake neighbor of node v_i . The discriminator, which we denoted as $D(v_j, v_i; \Phi)$, tries to tell whether a given pair of nodes (v_j, v_i) are connected or not in the graph. The output of the discriminator can be regarded as the probability of an edge existing between the two nodes v_j and v_i . The generator G and the discriminator D compete against each other: the generator G tries to fit the underlying probability distribution $p_{true}(v_j|v_i)$ perfectly such that the generated (selected) node v_j is relevant enough to the node v_i to fool the discriminator. While the discriminator tries to differentiate the nodes generated by the generator from the real neighbors of node v_i . Formally, the two models are playing the following minimax game:

$$\min_{\Theta} \max_{\Phi} V(G, D) = \sum_{v_i \in \mathcal{V}} \left(\mathbb{E}_{v_j \sim p_{true}(v_j|v_i)} \left[\log D(v_j, v_i; \Phi) \right] + \mathbb{E}_{v_j \sim G(v_j|v_i; \Theta)} \left[\log \left(1 - D(v_j, v_i; \Phi) \right) \right] \right)$$

The parameters of the generator G and the discriminator D can be optimized by alternatively maximizing and minimizing the objective function $V(G, D)$. Next, we describe the details of the design of the generator and the discriminator.

The Generator

A straightforward way to model the generator is to use a softmax function over all nodes \mathcal{V} as:

$$G(v_j|v_i; \Theta) = \frac{\exp(\theta_j^T \theta_i)}{\sum_{v_k \in \mathcal{V}} \exp(\theta_k^T \theta_i)}, \quad (9.15)$$

where $\theta_i \in \mathbb{R}^d$ denotes the d -dimensional representation for the node v_i specific to the generator, and Θ includes the representations for all nodes (They are also the parameters of the generator). Note that, in this formulation, the relevance between nodes are measured by the inner product of the representations of the two nodes. This idea is reasonable as we expect the low-dimensional representations to be closer if the two nodes are more relevant to each other. Once

the parameters Θ are learned, given a node v_i , the generator G can be used to sample nodes according to the distribution $G(v_j|v_i; \Theta)$. As we mentioned before, instead of generating fake nodes, the procedure of the generator should be more precisely described as selecting a node from the entire set \mathcal{V} .

While the softmax function in Eq. (9.15) provides an intuitive way to model the probability distribution, it suffers from severe computational issue. Specifically, the computational cost of the denominator of Eq. (9.15) is prohibitively expensive due to the summation over all nodes in \mathcal{V} . To solve this issue, hierarchical softmax (Morin and Bengio, 2005; Mikolov et al., 2013) introduced in Section 4.2.1 can be adopted.

The Discriminator

The discriminator is modeled as a binary classifier, which aims to tell whether a given pair of node (v_j, v_i) are connected with an edge in the graph or not. In detail, $D(v_j, v_i; \Phi)$ models the probability of the existence of an edge between nodes v_j and v_i as:

$$D(v_j, v_i; \Phi) = \sigma(\phi_j^\top \phi_i) = \frac{1}{1 + \exp(-\phi_j^\top \phi_i)}, \quad (9.16)$$

where $\phi_i \in \mathbb{R}^d$ is the low-dimensional representation of node v_i specific to the discriminator. We use the notation Φ to denote the union of representations of all nodes, which are the parameters of the discriminator to be learned. After training, the node representations from both the generator and discriminator or their combination can be utilized for the downstream tasks.

9.5.2 Generative Adversarial Networks for Graph Generation

The framework of generative adversarial networks has been adapted for graph generation in (De Cao and Kipf, 2018). Specifically, the GAN framework is adopted to generate molecular graphs. As similar to Section 9.4.2, a molecular graph \mathcal{G} with N nodes is represented by two objects: 1) A matrix $\mathbf{F} \in \{0, 1\}^{N \times t_e}$, which indicates the type of all nodes. The i -th row of the matrix \mathbf{F} corresponds to the i -th node and t_n is the number of node types (or different atoms); and 2) A tensor $\mathbf{E} \in \{0, 1\}^{N \times N \times t_e}$ indicating the type of all edges where t_e is the number of edge types (or different bonds). The generator's goal is not only to generate molecular graphs similar to a given set of molecules but also to optimize some specific properties such as the solubility of these generated molecules. Hence, in addition to the generator and the discriminator in the GAN framework, there is also a judge. It measures how good a generated graph is in terms of the specific property (to assign a reward). The judge is a network pre-trained on

some external molecules with ground truth. It is only used to provide guidance for generating desirable graphs. During the training procedure, the generator and discriminator are trained through competing against each other. However, the judge network is fixed and serves as a black box. Specifically, the generator and the discriminator are playing the following two-player minimax game:

$$\min_{\Theta} \max_{\Phi} \mathbb{E}_{\mathcal{G} \sim p_{data}(\mathcal{G})} [\log D(\mathcal{G}; \Phi)] + \mathbb{E}_{\mathbf{z} \sim p(\mathbf{z})} [\log(1 - D(G(\mathbf{z}; \Theta))) - \lambda J(G(\mathbf{z}; \Theta))],$$

where $p_{data}(\mathcal{G})$ denotes the true distribution of the given molecular graphs and $J()$ is the judge network. The judge network produces a scalar indicating some specific property of the input required to be maximized. Next, we describe the generator, the discriminator, and the judge network in the framework.

The Generator

The generator $G(\mathbf{z}; \Theta)$ is similar to the one we introduced in Section 9.4.2, where a fully connected probabilistic graph is generated given a latent representation \mathbf{z} sampled from a noise distribution $p(\mathbf{z}) = \mathcal{N}(0, \mathbf{I})$. Specifically, the generator $G(\mathbf{z}; \Theta)$ maps a latent representation \mathbf{z} to two continuous dense objects. They are used to describe the generated graph with k nodes – $\tilde{\mathbf{E}} \in \mathbb{R}^{k \times k \times t_e}$, which indicates the probability distributions of the type of edges; and $\tilde{\mathbf{F}} \in \mathbb{R}^{k \times t_n}$, which denotes the probability distribution of the types of nodes. To generate molecular graphs, discrete matrices of \mathbf{E} and \mathbf{F} are sampled from $\tilde{\mathbf{E}}$ and $\tilde{\mathbf{F}}$, respectively. During the training procedure, the continuous probabilistic graph $\tilde{\mathbf{E}}$ and $\tilde{\mathbf{F}}$ can be utilized such that the gradient can be successfully obtained through back-propagation.

The Discriminator and the Judge Network

Both the discriminator and the judge network receive a graph $\mathcal{G} = \{\mathbf{E}, \mathbf{F}\}$ as input, and output a scalar value. In (De Cao and Kipf, 2018), the graph neural network model is adopted to model these two components. In detail, the graph representation of the input graph \mathcal{G} is obtained as:

$$\mathbf{h}_{\mathcal{G}} = \text{pool}(\text{GNN}(\mathbf{E}, \mathbf{F})),$$

where $\text{GNN}()$ denotes several stacked graph filtering layers and $\text{pool}()$ indicates the graph pooling operation. Specifically, in (De Cao and Kipf, 2018), the gated global pooling operation introduced in Section 5.4.1 is adopted as the pooling operation to generate the graph representation $\mathbf{h}_{\mathcal{G}}$. The graph representation is then fed into a few more fully connected layers to produce a scalar value. In particular, in the discriminator, the produced scalar value between 0 and 1 measures the probability that the generated graph is a “real” molecular graph from the given set of graphs. Meanwhile, the judge network outputs a

scalar value that indicates the specific property of the graph. The discriminator needs to be trained alternatively with the generator. However, the judge network is pre-trained with the additional source of molecular graphs, and then it is treated as a fixed black box during the training of the GAN framework.

9.6 Conclusion

This chapter introduces more deep learning techniques on graphs. They include deep autoencoders, variational autoencoders (VAEs), recurrent neural networks (RNNs), and generative adversarial networks (GANs). Specifically, we introduce the graph autoencoders and recurrent neural networks, which are utilized to learn node representations. We then introduced two deep generative models: variational autoencoder and generative adversarial networks. We use the tasks of node representation learning and graph generation to illustrate how to adapt them to graphs.

9.7 Further Reading

Deep graph models beyond GNNs have greatly enriched deep learning methods on graphs and tremendously extended its application areas. In this chapter, we only introduce representative algorithms in one or two application areas. There are more algorithms and applications. In (Jin et al., 2018), variational autoencoder is utilized with graph neural networks for molecular graph generation. In (Ma et al., 2018b), additional constraints are introduced to variational graph autoencoders to generate semantically valid molecule graphs. In (You et al., 2018a), the GAN framework is combined with reinforcement learning techniques for molecule generation, where graph neural networks are adopted to model the policy network. Furthermore, recurrent neural networks are also utilized for graph generation (You et al., 2018b; Liao et al., 2019), where sequence of nodes and the connections between these nodes are generated.

PART THREE

APPLICATIONS

10

Graph Neural Networks in Natural Language Processing

10.1 Introduction

Graphs have been extensively utilized in natural language process (NLP) to represent linguistic structures. The constituency-based parse trees represent phrase structures for a given sentence. The syntactic dependency trees encode syntactic relations in terms of tree structures (Jurafsky and Martin, n.d.). Abstract meaning representation (AMR) denotes semantic meanings of sentences as rooted and labeled graphs that are easy for the program to traverse (Banarescu et al., 2013). These graph representations of natural languages carry rich semantic and/or syntactic information in an explicit structural way. Graph neural networks (GNNs) have been adopted by various NLP tasks where graphs are involved. These graphs include those mentioned above and also other graphs designed specifically for particular tasks. Specifically, GNNs have been utilized to enhance many NLP tasks such as semantic role labeling (Marcheggiani and Titov, 2017), (multi-hop) question answering (QA) (De Cao et al., 2019; Cao et al., 2019; Song et al., 2018a; Tu et al., 2019), relation extraction (Zhang et al., 2018c; Fu et al., 2019; Guo et al., 2019; Zhu et al., 2019b; Sahu et al., 2019; Sun et al., 2019a; Zhang et al., 2019d), neural machine translation (Marcheggiani et al., 2018; Beck et al., 2018), and graph to sequence learning (Cohen, 2019; Song et al., 2018b; Xu et al., 2018b). Furthermore, knowledge graphs, which encode multi-relational information in terms of graphs, are widely adopted by NLP tasks. There are also many works (Hamaguchi et al., 2017; Schlichtkrull et al., 2018; Nathani et al., 2019; Shang et al., 2019a; Wang et al., 2019c; Xu et al., 2019a) generalizing GNN models to knowledge graphs. In this chapter, we take semantic role labeling, neural machine translation, relation extraction, question answering, and graph to sequence learning as examples to demonstrate how graph neural networks can

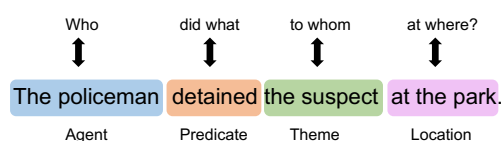

Figure 10.1 An illustrative sentence with semantic labels.

be applied to NLP tasks. We also introduce the graph neural network models designed for knowledge graphs.

10.2 Semantic Role Labeling

In (Marcheggiani and Titov, 2017), GNNs are utilized on syntactic dependency trees to incorporate syntactic information to improve the performance of Semantic Role Labeling (SRL). It is among the first to show that graph neural network models are effective on NLP tasks. In this section, we first describe the task of Semantic Role Labeling (SRL) and then introduce how GNNs can be leveraged for this task.

Semantic Role Labeling aims to discover the latent predicate-argument structure of a sentence, which can be informally regarded as the task of discovering “who did what to whom at where?”. For example, a sentence with semantic labels is shown in Figure 10.1 where the word “detained” is the predicate, “the policeman” and “the suspect” are its two arguments with different labels. More formally, the task of SRL involves the following steps: 1) detecting the predicates such as “detained” in Figure 10.1; and 2) identifying the arguments and labeling them with semantic roles, i.e., “the policeman” is the agent while “the suspect” is the theme. In (Marcheggiani and Titov, 2017), the studied SRL problem (on CoNLL-2009 benchmark) is simplified a little bit, where the predicate is given in the test time (e.g., we know that “detained” is the predicate in the example shown in Figure 10.1), hence no predicate detection is needed. The remaining task is to identify the arguments of the given predicate and label them with semantic roles. It can be treated as a sequence labeling task. In detail, the semantic role labeling model is asked to label all the arguments of the given predicate with their corresponding labels and label “NULL” for all the non-argument elements.

To tackle this problem, a Bi-directional LSTM (Bi-LSTM) encoder is adopted by (Marcheggiani and Titov, 2017) to learn context-aware word representations. These learned word representations are later utilized to label each of the

elements in the sequence. We denote a sentence as $[w_0, \dots, w_n]$, where each word w_i in the sequence is associated with an input representation \mathbf{x}_i . The input representation consists of four components: 1) a randomly initialized embedding; 2) a pre-trained word embedding; 3) a randomly initialized embedding for its corresponding part-of-speech tag; and 4) a randomly initialized lemma embedding, which is active only when the word is a predicate. These four embeddings are concatenated to form the input representation \mathbf{x}_i for each word w_i . Three of the embeddings except the pre-trained embedding are updated during the training. The sequence $[\mathbf{x}_0, \dots, \mathbf{x}_n]$ is then utilized as the input for the Bi-LSTM (Goldberg, 2016). Specifically, the Bi-LSTM model consists of two LSTMs with one dealing with the input sequence for the forward pass while the other handling the sequence for the backward pass. The operations of a single LSTM unit is introduced in Section 3.4.2. In the following, we abuse the notation a little bit to use $\text{LSTM}()$ to denote the process of dealing a sequence input with LSTM. The process of the forward and backward LSTM can be denoted as:

$$\begin{aligned} [\mathbf{x}_0^f, \dots, \mathbf{x}_n^f] &= \text{LSTM}^f([\mathbf{x}_0, \dots, \mathbf{x}_n]), \\ [\mathbf{x}_0^b, \dots, \mathbf{x}_n^b] &= \text{LSTM}^b([\mathbf{x}_n, \dots, \mathbf{x}_0]), \end{aligned}$$

where LSTM^f denotes the forward LSTM, which captures the left context for each word, while LSTM^b denotes the backward LSTM that captures the right context for each word. Note that, \mathbf{x}_i^b is the output representation from LSTM^b for the word w_{n-i} . The outputs of the two LSTMs are concatenated as the output of the Bi-LSTM, which captures the context information from both directions as:

$$[\mathbf{x}_0^{\text{bi}}, \dots, \mathbf{x}_n^{\text{bi}}] = \text{Bi-LSTM}([\mathbf{x}_0, \dots, \mathbf{x}_n]),$$

where \mathbf{x}_i^{bi} is the concatenation of \mathbf{x}_i^f and \mathbf{x}_{n-i}^b . With the output of Bi-LSTM, the labeling task is treated as a classification problem for each candidate word with the semantic labels and “NULL” as labels. Specifically, the input of the classifier is the concatenation of the output representations from the Bi-LSTM for the candidate word \mathbf{x}_c^{bi} and for the predicate \mathbf{x}_p^{bi} .

To enhance the algorithm described above, syntactic structure information is incorporated by utilizing graph neural network models on syntactic dependency trees (Marcheggiani and Titov, 2017). In detail, the aggregation process in the graph neural network model is generalized to incorporate directed labeled edges such that it can be applied to syntactic dependency trees. To incorporate the sentence’s syntactic information, the output of the Bi-LSTM layer is employed as the input of the graph neural network model. Then, the output of

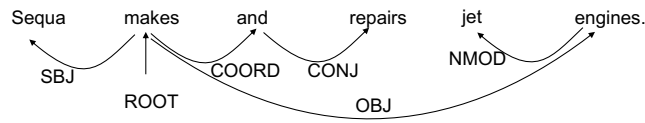

Figure 10.2 The dependency tree of the sentence “Sequa makes and repairs jet engines.”

the graph neural network model is used as the input for the linear classifier described above. Next, we first briefly introduce syntactic dependency trees and then describe how the graph neural network model is modified for syntactic dependency trees.

A syntactic dependency tree is a directed labeled tree encoding the syntactic dependencies in a given sentence. Specifically, the words in the sentence are treated as the nodes for the dependency tree while the directed edges describe the syntactic dependency between them. The edges are labeled with various dependency relations such as “Subject” (SBJ) and “Direct Object” (DOBJ). As an illustrative example, the dependency tree of the sentence “Sequa makes and repairs jet engines.” is shown in Figure 10.2, where “Sequa” is the subject of the verb “makes” and “engines” is the objective of “makes”. As the edges are directed and labeled in the dependency tree, to adopt the graph neural network model to incorporate the direction and label information in the edge, the following generalized graph filtering operator (for the l -th layer) is proposed in (Marcheggiani and Titov, 2017):

$$\mathbf{F}_i^{(l)} = \sigma \left(\sum_{v_j \in \mathcal{N}(v_i)} \mathbf{F}_j^{(l-1)} \Theta_{dir(i,j)}^{(l-1)} + \mathbf{b}_{lab(i,j)} \right), \quad (10.1)$$

where $\mathcal{N}(v_i)$ consists of both in-going and out-going neighbors of node v_i , $dir(i, j) \in \{\text{in-going, out-going}\}$ denotes the direction of the edge (v_i, v_j) in terms of the center node v_i , $\Theta_{dir(i,j)}^{(l-1)}$ are the parameters shared by the edges that have the same direction as (v_i, v_j) and $\mathbf{b}_{lab(i,j)}$ is a bias term to incorporate the label information on the edge with $lab(i, j)$ denoting the dependency relation of (v_i, v_j) . The filter described in Eq. (10.1) is utilized to build a graph neural network model with L layers for the SRL task.

10.3 Neural Machine Translation

Machine translation is an essential task in natural language processing. With the development of deep learning, neural networks have been widely adopted for machine translation. These neural networks based models are called as neural machine translation models, which usually take the form of encoder-decoder. The encoder takes a sequence of words in the source language as input and outputs a representation for each word in the sequence. Then the decoder, relying on the representations from the encoder, outputs a translation (or a sequence of words in the target language). Both the encoder and decoder are usually modeled with recurrent neural networks or their variants. For example, the Bi-LSTM introduced in Section 10.2 is a popular choice for the encoder while RNN models equipped with the attention mechanism (Bahdanau et al., 2014) is the popular choice for the decoder. In (Marcheggiani et al., 2018), to incorporate the syntactic structure information in the sentence to enhance the performance of machine translation, the same strategy that is introduced in Section 10.2 is adopted to design the encoder. The decoder keeps the same as the traditional model, i.e., the attention-based RNN model. Next, we briefly describe the encoder, as we have already introduced it in Section 10.2. Specifically, a Bi-LSTM model is first utilized for encoding the sequence. These representations from Bi-LSTM are then served as the input for a graph neural network model on the syntactic dependency tree. The formulation of a single graph filtering operation of the graph neural network model is shown in Eq. (10.1). The output of the graph neural network model is then leveraged as the input for the decoder (Bastings et al., 2017).

10.4 Relation Extraction

Graph Neural Networks have also been applied to the relation extraction (RE) task (Zhang et al., 2018c; Fu et al., 2019; Guo et al., 2019; Zhu et al., 2019b; Sahu et al., 2019; Sun et al., 2019a; Zhang et al., 2019d). Specifically, the works (Zhang et al., 2018c; Fu et al., 2019; Guo et al., 2019) adopt and/or modify the graph neural network model (i.e., Eq. (10.1)) in (Marcheggiani and Titov, 2017) to incorporate the syntactic information for the task of relation extraction. The first work applying graph neural networks to RE is introduced in (Zhang et al., 2018c). In this section, we briefly describe the task of RE and then use the model in (Zhang et al., 2018c) as an example to demonstrate how graph neural networks can be adopted to RE.

The task of relation extraction is to discern whether a relation exists between

two entities (i.e., *subject* and *object*) in a sentence. More formally, it can be defined as follows. Let $\mathcal{W} = [w_1, \dots, w_n]$ denote a sentence, where w_i is the i -th token in the sentence. An entity is a span consisting of consecutive words in the sentence. Specifically, a subject entity, which consists of a series of consecutive words, can be represented as $\mathcal{W}_s = [w_{s1} : w_{s2}]$. Similarly, an object entity can be expressed as $\mathcal{W}_o = [w_{o1} : w_{o2}]$. The goal of relation extraction is to predict the relation for the subject entity \mathcal{W}_s and the object entity \mathcal{W}_o given the sentence \mathcal{W} , where \mathcal{W}_s and \mathcal{W}_o are assumed to be given. The relation is from a predefined set \mathcal{R} , which also includes a special relation “no relation” indicating that there is no relation between these two entities. The problem of relation extraction is treated as a classification problem in (Zhang et al., 2018c). The input is the concatenation of the representations of the sentence \mathcal{W} , the subject entity \mathcal{W}_s and the object entity \mathcal{W}_o . The output labels are the relations in \mathcal{R} . Specifically, the relation prediction for a pair of entities is through a feed-forward neural network (FFNN) with parameters Θ_{FFNN} as shown below:

$$\mathbf{p} = \text{softmax}([\mathbf{F}_{sent}, \mathbf{F}_s, \mathbf{F}_o] \Theta_{FFNN}),$$

where $\text{softmax}()$ is the softmax function, \mathbf{p} is the probability distribution over the relations in the set \mathcal{R} , and $\mathbf{F}_{sent}, \mathbf{F}_s, \mathbf{F}_o$ represent the vector representations of the sentence, the subject entity and the object entity, respectively. To capture the context information of the sentence while also capturing the syntactic structure of the sentence, a very similar procedure as (Marcheggiani and Titov, 2017) (i.e. the model we introduced in Section 10.2 for SRL) is adopted to learn the word representations, which are then utilized to learn the representations for the sentence, subject entity and object entity. The major difference is that a self-loop is introduced to include the word itself during representation updating in Eq. (10.1). In other words, $\mathcal{N}(v_i)$ in Eq. (10.1) for RE consists of the node v_i , and its in-going and out-going neighbors. They also empirically find that including the direction and edge label information does not help for the RE task.

Given the word representations from the model consisting of L graph filtering layers described above, the representations for sentence, the subject entity and object entity are obtained by max pooling as:

$$\begin{aligned} \mathbf{F}_{sent} &= \max(\mathbf{F}^{(L)}), \\ \mathbf{F}_s &= \max(\mathbf{F}^{(L)}[s1 : s2]), \\ \mathbf{F}_o &= \max(\mathbf{F}^{(L)}[o1 : o2]), \end{aligned} \tag{10.2}$$

where $\mathbf{F}^{(L)}$, $\mathbf{F}^{(L)}[s1 : s2]$, and $\mathbf{F}^{(L)}[o1 : o2]$ denote the sequence of word rep-

representations for the entire sentence, the subject entity and the object entity, respectively. The max-pooling operation takes the maximum of each dimension and thus results in a vector with the same dimension as the word representation.

10.5 Question Answering

Machine reading comprehension (RC) or question answering (QA) aims to generate the correct answer for a given query/question by consuming and comprehending documents. It is an important but challenging task in NLP. Graph neural networks have been widely adopted to enhance the performance of the QA task, especially multi-hop QA (De Cao et al., 2019; Cao et al., 2019; Song et al., 2018a; Tu et al., 2019), where across-document reasoning is needed to answer a given query. This section introduces the multi-hop QA and one of the representative works, which utilize graph neural networks for this task. We first introduce the setting of multi-hop QA based on the WIKIHOP dataset (Welbl et al., 2018), which is created specifically for evaluating multi-hop QA models. We then describe the entity-GCN proposed in (De Cao et al., 2019) to tackle the multi-hop QA task.

10.5.1 The Multi-hop QA Task

In this subsection, we briefly discuss the setting of multi-hop QA based on the WIKIHOP dataset. The WIKIHOP dataset consists of a set of QA samples. Each sample can be denoted as a tuple (q, S_q, C_q, a^*) , where q is a query/question, S_q is a set of supporting documents, C_q is a set of candidate answers to be chosen from (all of which are entities in the set of supporting documents S_q) and $a^* \in C_q$ is the correct answer to the query. Instead of natural language, the query q is given in the form of a tuple $(s, r, ?)$, where s is the subject, r denotes the relation, and the object entity is unknown (marked as “?”) to be inferred from the support documents. A sample from the WIKIHOP dataset is shown in Figure 10.3, where the goal is to choose the correct “country” for the *Hanging Gardens of Mumbai* from the candidate set $C_q = \{\text{Iran, India, Pakistan, Somalia}\}$. In this example, to find the correct answer for the query, multi-hop reasoning is required: 1) from the first document, it can be figured out that *Hanging Gardens* are located in *Mumbai*; and 2) then, from the second document, it can be found that *Mumbai* is a city in *India*, which, together with the first evidence, can lead to the correct answer for the query. The goal of multi-hop QA is to learn a model that can identify the correct answer a^* for a given query q from

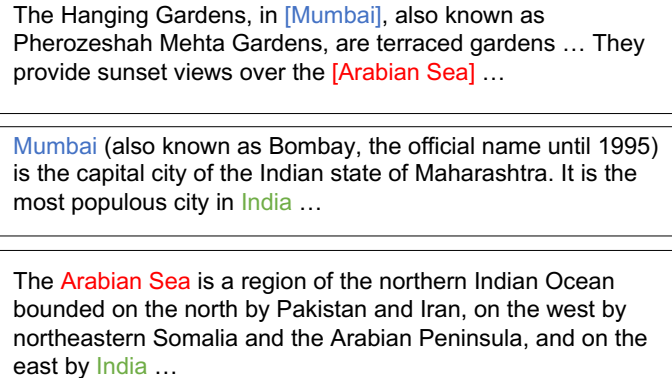

Q: {Hanging gardens of Mumbai, country, ?}

Options: {Iran, India, Pakistan, Somalia, ...}

Figure 10.3 A sample from the WIKIHOP dataset

the candidate set C_q by consuming and comprehending the set of the support documents S_q .

10.5.2 Entity-GCN

To capture the relations between the entities within- and across-documents and consequently help the reasoning process across documents, each sample (q, S_q, C_q, a^*) of the multi-hop QA task is organized into a graph by connecting mentions of candidate answers within and across the supporting documents. A generalized graph neural network model (i.e., Entity-GCN) is then proposed to learn the node representations, which are later used to identify the correct answer from the candidate sets for the given query. Note that L graph filtering layers are applied to ensure that each mention (or node) can access rich information from a wide range of neighborhoods. Next, we first describe how the graph is built and then introduce the process of solving the QA task using the proposed Entity-GCN.

Entity Graph

For a given sample (q, S_q, C_q, a^*) , to build a graph, the mentions of entities in $C_q \cup \{s\}$ are identified from the supporting document set S_q , and each mention is considered as a node in the graph. These mentions include 1) entities in S_q that exactly match an element in $C_q \cup \{s\}$ and 2) entities that are in the same

co-reference chain as an element in $C_q \cup \{s\}$. An end-to-end co-reference resolution technique (Lee et al., 2017) is utilized to discover the co-reference chains. Various types of edges are constructed to connect these mentions (or nodes) as follows: 1) “Match”: two mentions (either within or across documents) are connected by a “Match” edge, if they are identical; 2) “DOC-BASED”: two mentions are connected via “DOC-BASED” if they co-occur in the same support document; and 3) “COREF”: two mentions are connected by a “COREF” edge if they are in the same co-reference chain. These three types of edges describe three different types of relations between these mentions. Besides, to avoid disconnected components in the graph, the fourth type of edges is added between any pairs of nodes that are not connected. These edges are denoted as “COMPLEMENT” edges, which make the graph a complete graph.

Multi-step Reasoning with Entity-GCN on Entity Graph

To approach multi-step reasoning, a generalized graph neural network model Entity-GCN is proposed to transform and propagate the node representations through the built entity graph. Specifically, the graph filter (for the l -th layer) in Entity-GCN can be regarded as instantiating the MPNN framework in Eq. (5.40) to deal with edges of different types as:

$$\mathbf{m}_i^{(l-1)} = \mathbf{F}_i^{(l-1)} \Theta_s^{(l-1)} + \frac{1}{|\mathcal{N}(v_i)|} \sum_{r \in \mathcal{R}} \sum_{v_j \in \mathcal{N}_r(v_i)} \mathbf{F}_j^{(l-1)} \Theta_r^{(l-1)}, \quad (10.3)$$

$$\mathbf{a}_i^{(l-1)} = \sigma \left(\left[\mathbf{m}_i^{(l-1)}, \mathbf{F}_i^{(l-1)} \right] \Theta_a^{(l-1)} \right), \quad (10.4)$$

$$\mathbf{h}_i^{(l)} = \rho \left(\mathbf{m}_i^{(l-1)} \right) \odot \mathbf{a}_i^{(l-1)} + \mathbf{F}_i^{(l-1)} \odot \left(1 - \mathbf{a}_i^{(l-1)} \right), \quad (10.5)$$

where $\mathcal{R} = \{MATCH, DOC-BASED, COREF, COMPLEMENT\}$ denotes the set of types of edges, $\mathcal{N}_r(v_i)$ is the set of nodes connected with node v_i through edges of the type r , $\Theta_r^{(l-1)}$ indicates parameters shared by edges of the type r and $\Theta_s^{(l-1)}$ and $\Theta_a^{(l-1)}$ are shared by all nodes. The output in Eq. (10.4) is served as a gating system to control the information flow in the message update part of Eq. (10.5). The representation for each node v_i is initialized as:

$$\mathbf{F}_i^{(0)} = f_x(\mathbf{q}, \mathbf{x}_i),$$

where \mathbf{q} denotes the query representation from the pre-trained model ELMo (Peters et al., 2018) and \mathbf{x}_i is the pre-trained representation for node v_i from ELMo and $f_x(\cdot)$ is parameterized by a feed-forward neural network.

The final node representations $\mathbf{F}_i^{(L)}$ from the Entity-GCN with L graph filtering layers are used to select the answer for the given query from the candidate set. In detail, the probability of selecting a candidate $c \in C_q$ as the answer is

modeled as:

$$P(c|q, C_q, S_q) \propto \exp\left(\max_{v_i \in \mathcal{M}_c} f_o\left([\mathbf{q}, \mathbf{F}_i^{(L)}]\right)\right),$$

where f_o is a parameterized transformation, \mathcal{M}_c is the set of mentions corresponding to the candidate c , and the max operator is to select the mention in \mathcal{M}_c with the largest predicted probability for the candidate. In (Song et al., 2018a), instead of selecting the mention with the largest probability in \mathcal{M}_c , all mentions of a candidate c are utilized to model $P(c|q, C_q, S_q)$. Specifically,

$$P(c|q, C_q, S_q) = \frac{\sum_{v_i \in \mathcal{M}_c} \alpha_i}{\sum_{v_i \in \mathcal{M}} \alpha_i},$$

where we use \mathcal{M} to denote all the mentions, i.e., all nodes in the entity graph and α_i is modeled by the softmax function as:

$$\alpha_i = \frac{\exp\left(f_o\left([\mathbf{q}, \mathbf{F}_i^{(L)}]\right)\right)}{\sum_{v_i \in \mathcal{M}} \exp\left(f_o\left([\mathbf{q}, \mathbf{F}_i^{(L)}]\right)\right)}.$$

10.6 Graph to Sequence Learning

Sequence to sequence models have been broadly applied to natural language processing tasks such as neural machine translation (NMT) (Bahdanau et al., 2014) and natural language generation (NLG) (Song et al., 2017). Most of these proposed models can be viewed as encoder-decoder models. In an encoder-decoder model, an encoder takes a sequence of tokens as input and encodes it into a sequence of continuous vector representations. Then, a decoder takes the encoded vector representations as input and outputs a new target sequence. Usually, recurrent neural networks (RNNs) and its variants serve as both the encoder and the decoder. As the natural languages can be represented in terms of graphs, graph to sequence models have emerged to tackle various tasks in NLP, such as neural machine translation (NMT) (Marcheggiani et al., 2018; Beck et al., 2018) (see Section 10.3 for details) and AMR-to-text (Cohen, 2019; Song et al., 2018b). These graph to sequence models usually utilize graph neural networks as the encoder (or a part of the encoder) while still adopting RNN and its variants as its decoder. Specifically, the graph neural network model described in Eq. (10.1) (Marcheggiani and Titov, 2017) is utilized as encoder in (Marcheggiani et al., 2018; Song et al., 2018b; Cohen, 2019) for neural machine translation and AMR-to-text tasks. A general encoder-decoder

graph2seq framework for graph to sequence learning is proposed in (Xu et al., 2018b). It utilizes the graph neural network model as the encoder, and an attention mechanism equipped RNN model as the decoder. We first describe the GNN-based encoder model and then briefly describe the decoder.

GNN-based Encoder

Most of graphs in NLP applications such as the AMR and syntactic dependency trees are directed. Hence, the GNN-based encoder in graph2seq is designed to differentiate the incoming and outgoing neighbors while aggregating information. Specially, for a node v_i , its neighbors are split into two sets – the incoming neighbors $\mathcal{N}_{in}(v_i)$ and the outgoing neighbors $\mathcal{N}_{out}(v_i)$. The aggregation operation in GraphSAGE-Filter (See details on GraphSAGE-Filter in Section 5.3.2) is used to aggregate and update the node representations. Specifically, two node representations for each node are maintained, i.e., the in-representation and the out-representation. The updating process for node v_i in the l -th layer can be expressed as:

$$\begin{aligned} \mathbf{F}_{\mathcal{N}_{in}(v_i)}^{(l)} &= \text{AGGREGATE}(\{\mathbf{F}_{out}^{(l-1)}(v_j), \forall v_j \in \mathcal{N}_{in}(v_i)\}), \\ \mathbf{F}_{in}^{(l)}(v_i) &= \sigma([\mathbf{F}_{in}^{(l-1)}(v_i), \mathbf{F}_{\mathcal{N}_{in}(v_i)}^{(l)}] \Theta_{in}^{(l-1)}), \\ \mathbf{F}_{\mathcal{N}_{out}(v_i)}^{(l)} &= \text{AGGREGATE}(\{\mathbf{F}_{in}^{(l-1)}(v_j), \forall v_j \in \mathcal{N}_{out}(v_i)\}), \\ \mathbf{F}_{out}^{(l)}(v_i) &= \sigma([\mathbf{F}_{out}^{(l-1)}(v_i), \mathbf{F}_{\mathcal{N}_{out}(v_i)}^{(l)}] \Theta_{out}^{(l-1)}), \end{aligned}$$

where $\mathbf{F}_{in}^{(l)}(v_i)$ and $\mathbf{F}_{out}^{(l)}(v_i)$ denote the in- and out-representations for node v_i after l -th layer. As introduced for the GraphSAGE-Filter in Section 5.3.2, various designs for AGGREGATE() functions can be adopted. The final in- and out-representations after L graph filtering layers are denoted as $\mathbf{F}_{in}^{(L)}(v_i)$ and $\mathbf{F}_{out}^{(L)}(v_i)$, respectively. These two types of representations are concatenated to generate the final representations containing information from both directions as:

$$\mathbf{F}^{(L)}(v_i) = [\mathbf{F}_{in}^{(L)}(v_i), \mathbf{F}_{out}^{(L)}(v_i)].$$

After obtained the node representations, a graph representation is also generated by using pooling methods, which is used to initialize the decoder. The pooling process can be expressed as:

$$\mathbf{F}_G = \text{Pool}(\{\mathbf{F}^{(L)}(v_i), \forall v_i \in \mathcal{V}\}).$$

Here, various flat pooling methods such as max pooling and average pooling can be adopted. The decoder is modeled by an attention-based recurrent neural network. It attends to all node representations when generating each token of

the sequence. Note that the graph representation \mathbf{F}_G is utilized as the initial state of the RNN decoder.

10.7 Graph Neural Networks on Knowledge Graphs

Formally, a knowledge graph $G = (\mathcal{V}, \mathcal{E}, \mathcal{R})$ consists a set of nodes \mathcal{V} , a set of relational edges \mathcal{E} and a set of relations \mathcal{R} . The nodes are various types of entities and attributes, while the edges include different types of relations between the nodes. Specifically, an edge $e \in \mathcal{E}$ can be represented as a triplet (s, r, t) where $s, t \in \mathcal{V}$ are the source and target nodes of the edge respectively, and $r \in \mathcal{R}$ denotes the relation between them. Graph neural networks have been extended to knowledge graphs to learn node representations and thus facilitate various downstream tasks, including knowledge graph completion (Hamaguchi et al., 2017; Schlichtkrull et al., 2018; Nathani et al., 2019; Shang et al., 2019a; Wang et al., 2019f), node importance estimation (Park et al., 2019), entity linking (Zhang et al., 2019b) and cross-language knowledge graph alignment (Wang et al., 2018c; Xu et al., 2019e). The major difference between the knowledge graphs and simple graphs is the relational information, which is important to consider when designing graph neural networks for knowledge graphs. In this section, we first describe how graph neural networks are generalized to knowledge graphs. Especially, there are majorly two ways to deal with the relational edges in knowledge graphs: 1) incorporating the relational information of the edges into the design of graph filters; and 2) transforming the relational knowledge graph into a simple undirected graph by capturing the relational information. Then, we use the task of knowledge graph completion as an example to illustrate GNN based applications on knowledge graphs.

10.7.1 Graph Filters for Knowledge Graphs

Various graph filters have been specifically designed for knowledge graphs. We describe representative ones next. The **GCN-Filter** GGNN-Filter described in Eq. (5.22) is adapted to knowledge graphs (Schlichtkrull et al., 2018) as:

$$\mathbf{F}_i^{(l)} = \sum_{r \in \mathcal{R}} \sum_{v_j \in \mathcal{N}_r(v_i)} \frac{1}{|\mathcal{N}_r(v_i)|} \mathbf{F}_j^{(l-1)} \Theta_r^{(l-1)} + \mathbf{F}_i^{(l-1)} \Theta_0^{(l-1)}, \quad (10.6)$$

where $\mathcal{N}_r(v_i)$ denotes the set of neighbors that connect to node v_i through the relation r . It can be defined as:

$$\mathcal{N}(v_i) = \{v_j | (v_j, r, v_i) \in \mathcal{E}\}.$$

In Eq. (10.6), the parameters $\Theta_r^{(l-1)}$ are shared by the edges with the same relation $r \in \mathcal{R}$. Similar ideas can be also found in (Hamaguchi et al., 2017). Note that the Entity-GCN described in Section 10.5.2 is inspired by the graph filter in Eq. (10.6). In (Shang et al., 2019a), instead of learning different transformation parameters for different relations, a scalar score is learned to capture the importance for each relation. It leads to the following graph filtering operation:

$$\mathbf{F}_i^{(l)} = \sum_{r \in \mathcal{R}} \sum_{v_j \in \mathcal{N}_r(v_i)} \frac{1}{|\mathcal{N}_r(v_i)|} \alpha_r^{(l)} \mathbf{F}_j^{(l-1)} \Theta_r^{(l-1)} + \mathbf{F}_i^{(l-1)} \Theta_0^{(l-1)}, \quad (10.7)$$

where $\alpha_r^{(l)}$ is the importance score to be learned for the relation r .

To reduce the parameters involved in Eq. (10.6), relation embeddings are learned for different relations in (Vashishth et al., 2019). Specifically, the relation embeddings for all relations in \mathcal{R} after $l-1$ layer can be denoted as $\mathbf{Z}^{(l-1)}$ with $\mathbf{Z}_r^{(l-1)}$ the embedding for relation r . The relation embeddings can be updated for the l -th layer as:

$$\mathbf{Z}^{(l)} = \mathbf{Z}^{(l-1)} \Theta_{rel}^{(l-1)},$$

where $\Theta_{rel}^{(l-1)}$ are the parameters to be learned. We use $\mathcal{N}(v_i)$ to denote the set of neighbors of node v_i , which contains nodes that connect to v_i with different relations. Hence, we use (v_j, r) to indicate a neighbor of v_i in $\mathcal{N}(v_i)$, where v_j is the node connecting with v_i through the relation r . Furthermore, in (Vashishth et al., 2019), the reverse edge of any edge in \mathcal{E} is also treated as an edge. In other words, if $(v_i, r, v_j) \in \mathcal{E}$, (v_j, \hat{r}, v_i) is also considered as an edge with \hat{r} as the reverse relation of r . Note that, for convenience, we abuse the notation \mathcal{E} and \mathcal{R} a little bit to denote the augmented edge set and relation set. The relations now have directions and we use $dir(r)$ to denote the direction of a relation r . Specifically, $dir(r) = 1$ for all the original relations, while $dir(\hat{r}) = -1$ for all the reverse relations. The filtering operation is then designed as:

$$\mathbf{F}_i^{(l)} = \sum_{(v_j, r) \in \mathcal{N}(v_i)} \phi(\mathbf{F}_j^{(l-1)}, \mathbf{Z}_r^{(l-1)}) \Theta_{dir(r)}^{(l-1)}, \quad (10.8)$$

where $\phi(\cdot)$ denotes non-parameterized operations such as subtraction and multiplication and $\Theta_{dir(r)}^{(l-1)}$ are parameters shared by all the relations with the same direction.

10.7.2 Transforming Knowledge Graphs to Simple Graphs

In (Wang et al., 2018c), instead of designing specific graph filtering operations for knowledge graphs, a simple graph is built to capture the directed relational

information in knowledge graphs. Then, existing graph filtering operations can be naturally applied to the transformed simple graph.

Two scores are proposed to measure the influence of an entity to another entity through a specific type of relation r as:

$$\begin{aligned} \text{fun}(r) &= \frac{\#\text{Source_with_r}}{\#\text{Edges_with_r}}, \\ \text{ifun}(r) &= \frac{\#\text{Target_with_r}}{\#\text{Edges_with_r}}, \end{aligned}$$

where $\#\text{Edges_with_r}$ is the total number of edges with the relation r , $\#\text{Source_with_r}$ denotes the number of unique source entities with relation r and $\#\text{Target_with_r}$ indicates the number of unique target entities with relation r . Then, the overall influence of the entity v_i to the entity v_j is defined as:

$$\mathbf{A}_{i,j} = \sum_{(v_i,r,v_j) \in \mathcal{E}} \text{ifun}(r) + \sum_{(v_j,r,v_i) \in \mathcal{E}} \text{fun}(r),$$

where $\mathbf{A}_{i,j}$ is the i, j -th element for the adjacency matrix \mathbf{A} of the generated simple graph.

10.7.3 Knowledge Graph Completion

Knowledge graph completion, which aims to predict the relation between a pair of disconnected entities, is an important task as knowledge graphs are usually incomplete or fast evolving with new entities emerging. Specifically, the task is to predict whether a given triplet (s, r, t) is a real relation or not. To achieve this goal, we need to assign a score $f(s, r, t)$ to the triplet (s, r, t) to measure the probability of the triplet being a real relation. Especially, the DistMult factorization (Yang et al., 2014) is adopted as the scoring function, which can be expressed as:

$$f(s, r, t) = \mathbf{F}_s^{(L)\top} \mathbf{R}_r \mathbf{F}_t^{(L)},$$

where $\mathbf{F}_s^{(L)}$ and $\mathbf{F}_t^{(L)}$ are the representations of source node s and target node t , respectively. They are learned by graph neural networks after L filtering layers; \mathbf{R}_r is a diagonal matrix corresponding to the relation r to be learned during training. The model can be trained using negative sampling with cross-entropy loss. In particular, for each observed edge sample $e \in \mathcal{E}$, k negative samples are generated by randomly replacing either its subject or object with another entity. With the observed samples and the negative samples, the cross-entropy loss to be optimized can be expressed as:

$$\mathcal{L} = -\frac{1}{(1+k)|\mathcal{E}|} \sum_{(s,r,o,y) \in \mathcal{T}} y \log \sigma(f(s, r, o)) + (1-y) \log(1 - \sigma(f(s, r, o))),$$

where \mathcal{T} denotes the set of the positive samples observed in \mathcal{E} and randomly generated negative samples and y is an indicator that is set to 1 for the observed samples and 0 for the negative samples.

10.8 Conclusion

In this chapter, we introduce how graph neural networks can be applied to natural language processing. We present representative tasks in natural language processing, including semantic role labelling, relation extraction, question answering, and graph to sequence learning, and describe how graph neural networks can be employed to advance their corresponding models' performance. We also discuss knowledge graphs, which are widely used in many NLP tasks and present how graph neural networks can be generalized to knowledge graphs.

10.9 Further Reading

Besides graph neural networks, the Graph-LSTM algorithms we introduced in Section 9.3 have also been adopted to advance the relation extraction tasks (Miwa and Bansal, 2016; Song et al., 2018c). In addition, graph neural networks have been applied to many other NLP tasks such as abusive language detection (Mishra et al., 2019), neural summarization (Fernandes et al., 2018), and text classification (Yao et al., 2019). The Transformer (Vaswani et al., 2017) has been widely adopted to deal with sequences in natural language processing. The pre-trained model BERT (Devlin et al., 2018), which is built upon transformer, has advanced many tasks in NLP. When applying to a given sequence, the transformer can be regarded as a special graph neural network. It is applied to the graph induced from the input sequence. In detail, the sequence can be regarded as a fully connected graph, where elements in the sequence are treated as the nodes. Then a single self-attention layer in the transformer is equivalent to the GAT-Filter layer (see Section 5.3.2 for details of GAT-Filter).

11

Graph Neural Networks in Computer Vision

11.1 Introduction

Graph-structured data widely exists in numerous tasks in the area of computer vision. In the task of visual question answering, where a question is required to be answered based on content in a given image, graphs can be utilized to model the relations among the objects in the image. In the task of skeleton-based recognition, where the goal is to predict human action based on the skeleton dynamics, the skeletons can be represented as graphs. In image classification, different categories are related to each other through knowledge graphs or category co-occurrence graphs (Wang et al., 2018b; Chen et al., 2019c). Furthermore, point cloud, which is a type of irregular data structure representing shapes and objects, can also be denoted as graphs. Therefore, graph neural networks can be naturally utilized to extract patterns from these graphs to facilitate the corresponding computer vision tasks. This chapter demonstrates how graph neural networks can be adapted to the aforementioned computer vision tasks with representative algorithms.

11.2 Visual Question Answering

Given an image and a question described in natural language, the task of visual question answering (VQA) is to answer the question based on the information provided in the image. An illustrative example of the VQA task is shown in Figure 11.1, where the task is to figure out the color of the fruit at the left of the image. To perform the VQA task properly, it is necessary to understand the question and the image, which requires techniques from both natural language processing and computer vision. Typically, Convolutional Neural Networks (CNNs) are adopted to learn the image representation. Then, it is combined

Image I :

Question q : What is the color of fruit at the left?

Figure 11.1 An illustrative example of the VQA task

with the representation of the question to perform the VQA task. As illustrated in Figure 11.1, the relations between objects in the image can also be important to answer the question correctly. Better capturing the semantic and spatial relations between the objects can potentially facilitate the VQA task. For example, to answer the question q in Figure 11.1 properly, the relative locations between the fruits are necessary. To denote the objects' interactions explicitly, graphs are adopted to model the connections between objects. Graph neural networks are then adopted to learn the representations for these graphs generated from images (Teney et al., 2017; Norcliffe-Brown et al., 2018). Specifically, some works assume that the graph is given for each image (Teney et al., 2017), while others incorporate the graph generation process as a part of the proposed models (Norcliffe-Brown et al., 2018). In this section, we introduce the two models proposed in (Teney et al., 2017) and (Norcliffe-Brown et al., 2018) as examples to show how graph neural networks can be adopted in the VQA task.

The task of VQA is modeled as a classification problem, where each class corresponds to one of the most common answers in the training set. Formally, each sample of this classification problem can be denoted as (q, I) , where q is the question, and I is the image. To tackle this classification problem utilizing the information from the question and the image, their representations are learned and combined to serve as the input for the prediction layer based on feedforward network. In (Norcliffe-Brown et al., 2018), the image is transferred to a graph in an end-to-end manner while training the entire framework. In (Teney et al., 2017), both the question q and the image I are pre-processed as graphs and dealt with graph neural networks.

11.2.1 Images as Graphs

In (Norcliffe-Brown et al., 2018), the question q is encoded to a representation \mathbf{q} using RNN with GRU. To learn the representation for the image I , a graph is generated from the image I dependent on the question q , and a graph neural network model is applied on the generated graph to learn its representation. Next, we first describe how the graph is generated given the image I and the question representation \mathbf{q} . Then, we introduce the graph neural network model to learn the graph representation \mathbf{F}_I . Finally, we briefly describe the prediction layer, which takes the representations for the question q and the image I as input.

Given an image I , and a set of n visual features bounded by boxes generated by an object detector. Each bounding box serves as a node in the generated graph. An initial representation \mathbf{x}_i is produced for each node v_i by taking the average of the corresponding convolutional feature maps in the bounding box. These nodes consist of the node set for the generated graph, denoted as \mathcal{V}_I . We then generate the set of edges \mathcal{E}_I to describe the relations between these nodes. These edges are constructed based on the pair-wise similarity and the relevance to the given question q . To combine these two types of information, for each node, a question-dependent representation is generated as:

$$\mathbf{e}_i = h([\mathbf{x}_i, \mathbf{q}]),$$

where \mathbf{e}_i is the question-dependent node representation for node v_i and $h()$ is a non-linear function to combine these two types of information. The question-dependent representations for all nodes can be summarized by a matrix \mathbf{E} where the i -th row is corresponding to the i -th node in the generated graph. Then the adjacency matrix of the graph is calculated as:

$$\mathbf{A} = \mathbf{E}\mathbf{E}^T. \quad (11.1)$$

However, the adjacency matrix learned by Eq. (11.1) is fully connected, which is not optimal for both efficiency and the performance of the model. Hence, to generate a sparse adjacency matrix, only the stronger connections for each node are kept. Specifically, we only keep the top m values of each row and set other values to 0, where m is a hyper-parameter. The graph generated for image I is denoted as \mathcal{G}_I .

After obtaining the question-dependent graph \mathcal{G}_I for the objects detected in the image, the Mo-Filter introduced in Section 5.3.2 is adapted to generate the node representations. The operation for a node v_i can be formulated as:

$$\mathbf{F}_i^{(l)} = \sum_{v_j \in \mathcal{N}(v_i)} w(\mathbf{u}(i, j)) \mathbf{F}_j^{(l-1)} \alpha_{i,j}, \quad (11.2)$$

where $\mathcal{N}(v_i)$ denotes the set of neighbors for node v_i , $w(\cdot)$ is a learnable Gaussian kernel, $\alpha_{i,j} = \text{softmax}(\mathbf{A}_i)[j]$ indicates the strength of connectivity between nodes v_i and v_j , and $\mathbf{u}(i, j)$ is a pseudo-coordinate function. This pseudo-coordinate function $\mathbf{u}(i, j)$ returns a polar coordinate vector (ρ, θ) , which describes the relative spatial positions of the centers of the bounding boxes corresponding to nodes v_i and v_j . After applying L consecutive graph filtering layers as described in Eq. (11.2), the final representation for each node v_i is obtained as $\mathbf{F}_i^{(L)}$. In (Norcliffe-Brown et al., 2018), K different Gaussian kernels are used and the output representations of the K kernels are combined as:

$$\mathbf{F}_i = \parallel_{k=1}^K \mathbf{F}_{ik}^{(L)} \Theta_k,$$

where $\mathbf{F}_{ik}^{(L)}$ is the output from the k -th kernel and Θ_k is a learnable linear transformation. The final representations for all the nodes in the graph can be summarized in a matrix \mathbf{F} where each row corresponds to a node.

Once these final node representations are obtained, a max-pooling layer is applied to generate the representation \mathbf{F}_I for the graph \mathcal{G}_I . The graph representation \mathbf{F}_I and the question representation \mathbf{q} are combined through the element-wise product to generate the task representation, which is then input into the feedforward network-based prediction layer to perform the classification.

11.2.2 Images and Questions as Graphs

In (Teney et al., 2017), both the question q and the image I are pre-processed as graphs. The question q is modeled as a syntactic dependency tree. In the tree, each word in the sentence is a node, and the dependency relations between words are edges. We denote the graph generated for a question q as $\mathcal{G}_q = \{\mathcal{V}_q, \mathcal{E}_q, \mathcal{R}_q\}$, where \mathcal{R}_q is the set of possible dependency relations. Meanwhile, the image I is pre-processed as a fully connected graph. In the graph, the objects in the image I are extracted as nodes, and they are pair-wisely connected. We denote the graph generated for the image I as $\mathcal{G}_I = \{\mathcal{V}_I, \mathcal{E}_I\}$. Each object (or node) $v_i \in \mathcal{V}_I$, is associated with its visual features \mathbf{x}_i while each edge $(v_i, v_j) \in \mathcal{E}_I$ between nodes v_i and v_j is associated with a vector \mathbf{x}_{ij} that encodes the relative spatial relations between v_i and v_j .

Both graphs are processed with graph neural networks to generate node representations, which are later combined to generate a representation for the pair (q, I) . In (Teney et al., 2017), a slightly modified version of GGNN-Filter as introduced in Section 5.3.2, is utilized to process these two graphs. The modified

GGNN-Filter can be described as:

$$\mathbf{m}_i = \sum_{v_j \in \mathcal{N}(v_i)} \mathbf{x}'_{ij} \odot \mathbf{x}'_j, \quad (11.3)$$

$$\mathbf{h}_i^{(t)} = \text{GRU}([\mathbf{m}_i, \mathbf{x}'_i], \mathbf{h}_i^{(t-1)}); t = 1, \dots, T, \quad (11.4)$$

where \mathbf{x}'_j and \mathbf{x}'_{ij} are the features for node v_j and edge (v_i, v_j) , respectively. For the question graph \mathcal{G}_q , \mathbf{x}'_j and \mathbf{x}'_{ij} are randomly initialized. In detail, node features are word-specific, i.e., each word is initialized with a representation while edge features are relation specific, i.e., edges with the same relation $r \in \mathcal{R}_q$ share the same features. For the image graph \mathcal{G}_I , \mathbf{x}'_i and \mathbf{x}'_{ij} are transformed using feedforward networks from the associated features \mathbf{x}_i and \mathbf{x}_{ij} , respectively. In Eq. (11.4), the GRU update unit (with $\mathbf{h}_0^{(0)} = \mathbf{0}$) runs T times and finally obtains the final representation $\mathbf{h}_i^{(T)}$ for node v_i . Note that, in (Teney et al., 2017), a single layer of graph filter as described in Eq. (11.3) and Eq. (11.4) is utilized to process the graphs. In other words, there are a single aggregation step and T GRU update steps. We denote the final node representations learned from the graph filtering as $\mathbf{h}_i^{(T,q)}$ and $\mathbf{h}_j^{(T,I)}$ for node $v_i \in \mathcal{V}_q$ in the question graph \mathcal{G}_q and $v_j \in \mathcal{V}_I$ in the image graph \mathcal{G}_I , respectively. These node representations from the two graphs are combined as:

$$\mathbf{h}_{i,j} = \alpha_{i,j} \cdot [\mathbf{h}_i^{(T,q)}, \mathbf{h}_j^{(T,I)}], i = 1, \dots, |\mathcal{V}_q|; j = 1, \dots, |\mathcal{V}_I|, \quad (11.5)$$

$$\mathbf{h}'_i = f_1 \left(\sum_{j=1}^{|\mathcal{V}_I|} \mathbf{h}_{i,j} \right), \quad (11.6)$$

$$\mathbf{h}_{(q,I)} = f_2 \left(\sum_{i=1}^{|\mathcal{V}_q|} \mathbf{h}'_i \right), \quad (11.7)$$

where $\alpha_{i,j}$ in Eq. (11.5), which is learned using the raw features \mathbf{x}' , can be regarded as a relevance measure between a question node and an image node. Specifically, it can be modeled as:

$$\alpha_{i,j} = \sigma \left(f_3 \left(\frac{\mathbf{x}'_i{}^Q}{\|\mathbf{x}'_i{}^Q\|} \odot \frac{\mathbf{x}'_j{}^I}{\|\mathbf{x}'_j{}^I\|} \right) \right),$$

where we use the superscripts Q and I to differentiate the features for nodes from the question graph and the image graph respectively, \odot is the Hadamard product, $f_3(\cdot)$ is modeled as a linear transformation and $\sigma(\cdot)$ is the sigmoid function. $\mathbf{h}_{i,j}$ is a mixed representation of a node from the question graph and a node from the image graph. These representations $\mathbf{h}_{i,j}$ are hierarchically aggregated to generate the representation $\mathbf{h}_{(q,I)}$ for the pair (q, I) in Eq. (11.6) and

Eq. (11.7), where $f_1()$ and $f_2()$ are feedforward neural networks. The representation can be utilized to perform the classification on the candidate sets.

11.3 Skeleton-based Action Recognition

Human action recognition is an active research area, which plays a vital role in video understanding. Human body skeleton dynamics can capture important information about human actions, which have been often leveraged for action recognition. The skeleton dynamics can be naturally modeled as a time series of human joint locations and interactions between them. Especially, the spatial relations between the joints can be modeled as a graph with the joints as the nodes and bones as edges connecting them. Then, the skeleton dynamics can be represented as a sequence of graphs which share the same spatial structure while the node attributes (or location coordinates of the joints) of the graph in the sequence are different. Graph neural networks have been adopted to learn better representations of the skeleton dynamics and thus improve the performance of skeleton-based action recognition (Yan et al., 2018; Li et al., 2018a; Shi et al., 2019a; Si et al., 2018; Wen et al., 2019; Li et al., 2019c; Si et al., 2019). In this section, we take the framework proposed in (Yan et al., 2018) as one example to demonstrate how graph neural networks can be applied to the skeleton-based action recognition task. It is the first to explore graph neural networks for skeleton-based action recognition.

As shown in Figure 11.2, a sequence of skeletons is represented as a spatial-temporal graph $\mathcal{G} = \{\mathcal{V}, \mathcal{E}\}$, where \mathcal{V} denotes the set of nodes and \mathcal{E} is the set of edges, respectively. The node set \mathcal{V} consists of all the joints in the skeleton sequence, i.e., $\mathcal{V} = \{v_{it} | t = 1, \dots, T; i = 1, \dots, N\}$ where N is the number of joints in a single skeleton graph, and T is the number of skeletons in the sequence. The edge set \mathcal{E} consists of two types of edges: 1) the intra-skeleton edges within the same skeleton, which are defined based on the bones between the joints; and 2) the inter-skeleton edges, which connect the same joints in consecutive skeletons in the sequence. For the illustrative example in Figure 11.2, the intra-skeleton edges are highlighted by green while the inter-skeleton edges are shown in blue. The skeleton-based action recognition task can then be converted into a graph classification task where the classes are the actions to predict, such as running. To perform this graph classification task, a graph filtering operation is proposed for the spatial-temporal graph to learn node representations. After the node representations are learned, the graph representation is obtained by applying a global pooling layer, such as max-pooling. The graph representation is then utilized as the input to the feed-

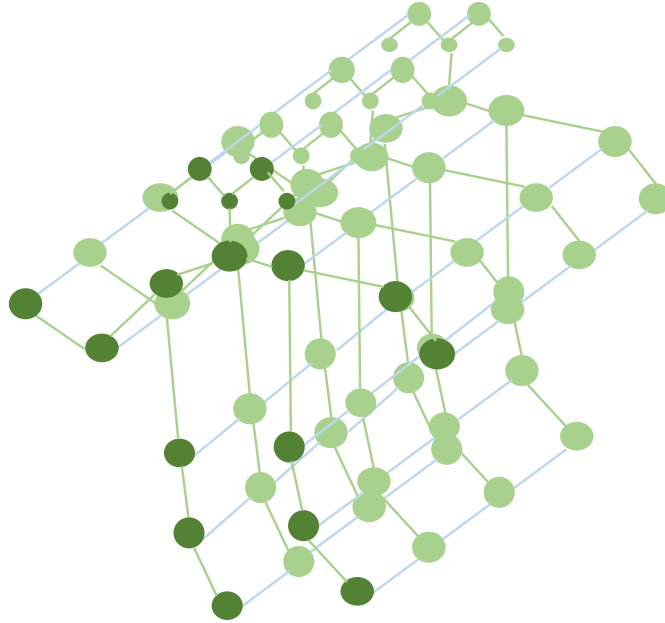

Figure 11.2 An illustrative example of the spatial-temporal skeleton graph

forward networks-based prediction layer. Next, we present the details of the proposed graph filter for the spatial-temporal graph.

The proposed graph filter is adapted from the GCN-Filter (see Section 5.3.2 for details of GCN-Filter), which aggregates information from neighboring nodes in the spatial-temporal graph. Specifically, for a node v_{ii} in the t -th skeleton, its spatial neighbors $\mathcal{N}(v_{ii})$ consist of its 1-hop neighbors in the t -th skeleton graph and the node v_{ii} itself. Then its spatial temporal neighbors $\mathcal{N}^T(v_{ii})$ on the spatial-temporal graph \mathcal{G} can be defined as:

$$\mathcal{N}^T(v_{ii}) = \{v_{\tau j} | v_{\tau j} \in \mathcal{N}(v_{ii}) \text{ and } |\tau - t| \leq \Gamma\}. \quad (11.8)$$

The constraint $|\tau - t| \leq \Gamma$ in Eq. (11.8) indicates that the temporal distance between these two skeleton graphs where the nodes $v_{\tau j}$ and v_{ij} locate should be smaller than Γ . Hence, the spatial temporal neighbors $\mathcal{N}^T(v_{ii})$ of node v_{ii} include not only its spatial neighbors from the same skeleton but also “temporal neighbors” from close skeletons in the sequence. Furthermore, instead of treating the neighbors equally, neighbors are split into different subsets and different transformation matrices are utilized for their transformation. In particular, the spatial neighbors $\mathcal{N}(v_{ii})$ of a node v_{ii} in a skeleton graph are divided to

three subsets as follows: 1) the root node itself (i.e., node v_{ii}); 2) the neighboring nodes that are closer to the gravity center of skeleton than the root node; and 3) all other nodes. The neighboring nodes of node v_{ii} in other skeleton graphs can be divided similarly; hence, the neighboring set $\mathcal{N}^T(v_{ii})$ can be divided into $3(2\Gamma + 1)$ sets. For convenience, we use $s(v_{\tau_j})$ to indicate the subset a given node $v_{\tau_j} \in \mathcal{N}^T(v_{ii})$ belongs to. Then, the graph filtering process for a given node v_{ii} can be described as:

$$\mathbf{F}_{ii}^{(l)} = \sum_{v_{\tau_j} \in \mathcal{N}^T(v_{ii})} \frac{1}{\#s(v_{\tau_j})} \cdot \mathbf{F}_{\tau_j}^{(l-1)} \Theta_{s(v_{\tau_j})}^{(l-1)}, \quad (11.9)$$

where $\mathbf{F}_{ii}^{(l)}$ denotes node representations of node v_{ii} after l -th layer, and $\mathbf{F}_{\tau_j}^{(l-1)}$ denotes node representations of node v_{τ_j} after $(l - 1)$ -th layer. $\#s(v_{\tau_j})$ denotes the number of neighbors that are in the subset v_{τ_j} and the transformation parameter $\Theta_{s(v_{\tau_j})}^{(l-1)}$ is shared by all the neighbors belonging to the subset $s(v_{\tau_j})$. The node representations are learned by stacking L graph filtering layers as Eq. (11.9) with activation layers. Then, the graph representation is obtained by applying a global pooling layer to these node representations. Note that in the framework we introduced above, the relations between the joints in the skeleton are naturally defined through the bones. Hence, only spatially close joints are connected to each other. However, it is possible that some distant joints are also related especially when doing some specific actions. For example, two hands are highly related to each other when doing the action “clapping hands”. Thus, it is important to also encode relations between distant joints. In (Shi et al., 2019b,a; Li et al., 2019c), the graphs between the joints are learned together with the parameters of the model.

11.4 Image Classification

Image classification aims to classify an image into certain categories. Graph neural networks have been adopted to advance image classification, especially under zero-shot, few-shot and multi-label settings. In this section, we discuss GNN based image classification under these three settings with representative algorithms. As shown in Figure 3.11 in Section 3.3.5, a CNN-based image classifier usually consists of two parts: 1) feature extraction, which is built with convolutional and pooling layers; and 2) the classification component, which is typically modeled as a fully connected layer. Specifically, this fully connected layer (without considering the softmax layer) can be represented as a matrix $\mathbf{W} \in \mathbb{R}^{d \times c}$, where d is the dimension of the extracted features, and c is the number of categories in the task. The i -th row of \mathbf{W} denoted as

\mathbf{w}_i is corresponding to the i -th category, which indicates how likely a given sample is classified to the i -th category. In this section, we loosely call \mathbf{w}_i as the “classifier” of the i -th category.

11.4.1 Zero-shot Image Classification

In the traditional setting of the image classification task in computer vision, abundant images of each category are assumed to be available for training the classifiers for these categories. These learned classifiers can only recognize the images from the categories they are trained with. To recognize images from a new category, thousands of images of this category are required, and their corresponding classifiers must be retrained together with newly collected images. The task of zero-shot image classification is to learn a classifier for a new category without any training images but only based on information about the category, such as its description or its relations with other categories. Graph neural networks are adopted in (Wang et al., 2018b) to learn classifiers for categories without any training images by propagating information from other categories through a knowledge graph describing the relations between categories. Next, we first formally describe the setting of the zero-shot image classification task and then present how graph neural networks are adopted to tackle this problem.

In the zero-shot image classification setting, we are given a set of n categories, among which the first m of them have sufficient training images while the remaining $n - m$ categories are with no images. Each category c_i is associated with a short description, which can be projected to a semantic embedding \mathbf{x}_i . Furthermore, there is a knowledge graph (e.g., WordNet (Miller, 1998)) $\mathcal{G} = \{\mathcal{V}, \mathcal{E}\}$ describing the relations between these categories, where the categories are the nodes. In the introduction of this section, we use \mathbf{w}_i to loosely denote a “classifier” of a category c_i . For a linear classifier such as logistic regression for a given category c_i , it can be also represented by its parameters $\mathbf{w}_i \in \mathbb{R}^d$, where d is the dimension of the features of the input image. Given an image, its features can be extracted using some pre-trained Convolutional Neural Networks. For those m categories with sufficient training samples, their corresponding classifier can be learned from these training samples. The goal of the zero-shot image classification task is to learn classifiers for those $n - m$ categories without any images by leveraging their semantic embeddings and/or the given knowledge graph \mathcal{G} .

A straightforward way to predict the classifiers is to adopt a neural network that takes the semantic embedding of a category as input and produces its corresponding classifier as output. However, in practice, the number of categories with sufficient training samples is generally too small (e.g., in the order

of hundreds) to train the neural network. Hence, instead of deep neural networks, the graph neural network model is adopted to predict the classifiers. The graph neural network model is applied to the knowledge graph with the semantic embeddings of categories as input, and its output is the corresponding classifiers of these categories. In (Wang et al., 2018b), GCN-Filter (see Section 5.3.2 for details on GCN-Filter) is adopted as the graph filtering operation, and L graph filtering layers are stacked to refine the features (with the semantic embeddings as the initial features) before finally obtaining the classifiers. Specifically, the task can be modeled as a regression problem, where the classifiers $\{\mathbf{w}_1, \dots, \mathbf{w}_m\}$ for the first m categories are served as the ground truth. In (Wang et al., 2018b), the number of layers L is set to a relatively large number (e.g., 6) such that distant information can be propagated through the knowledge graph. However, it is empirically shown that increasing the number of layers of graph neural networks may hurt the performance (Kampffmeyer et al., 2019). Hence, to propagate distant information without reducing the performance, a dense graph is constructed from the given knowledge graph. Any given node is connected to all its ancestors in the knowledge graph. Two graph filtering layers are applied based on the constructed dense graph. In the first layer, information is only aggregated from descendants to ancestors, while in the second layer, information flows from ancestors to descendants.

11.4.2 Few-shot Image Classification

In zero-shot learning, we aim to learn classifiers for unseen categories without any training samples. In the setting of few-shot learning image classification, we are given a set of n categories, among which the first m categories have sufficient training images while the remaining $n - m$ categories are with only k labeled images, where k is usually a very small number such as 3. Specifically, when $k = 0$, it can be treated as the zero-shot image classification task. In this section, we specifically focus on the case where $k > 0$.

In few-shot image classification, as all categories have labeled images (either sufficient or not), classifiers can be learned for all categories. We denote the classifier learned for the i -th category as \mathbf{w}_i . The classifiers $\{\mathbf{w}_1, \dots, \mathbf{w}_m\}$ learned for those m categories with sufficient labeled training images are good and can be employed to perform predictions on unseen samples. However, the classifiers $\{\mathbf{w}_{m+1}, \dots, \mathbf{w}_n\}$ for the $n - m$ categories with only k images may not be sufficient to perform reasonable predictions. Hence, the goal is to learn better classifiers for these $n - m$ categories.

A similar approach as that introduced in Section 11.4.1 can be used to refine the classifiers $\{\mathbf{w}_{m+1}, \dots, \mathbf{w}_n\}$. Specifically, these learned classifiers $\{\mathbf{w}_{m+1}, \dots, \mathbf{w}_n\}$

can be used as the input of a GNN model to produce the refined classifiers. The GNN model can be trained on those categories with sufficient labels (Gidaris and Komodakis, 2019). Especially, to mimic the process of refining less-well trained classifiers to generate well-trained classifiers, for each of the categories with sufficient training samples, we can sample k training samples to form a “fake” training set, which simulates the setting of those categories with only k labeled samples. Then, a set of classifiers $\{\hat{\mathbf{w}}_1, \dots, \hat{\mathbf{w}}_m\}$ can be learned from the “fake” training sets. These “fake” classifiers $\{\hat{\mathbf{w}}_1, \dots, \hat{\mathbf{w}}_m\}$ and the ones learned with sufficient training samples $\{\mathbf{w}_1, \dots, \mathbf{w}_m\}$ can be used as training data to train the GNN model. Specifically, the GNN model is similar to the one introduced in Section 11.4.1, where the difference is that, instead of using word embedding as input, the model now takes the “fake” classifiers as input. After training, the GNN model can be utilized to refine the classifiers $\{\mathbf{w}_{m+1}, \dots, \mathbf{w}_n\}$ for those categories with k training samples. As mentioned in Section 11.4.1, knowledge graphs describing the relations between the categories can be used as the graphs, which the GNN model is applied to. In (Gidaris and Komodakis, 2019), the graph between the categories is built upon the similarity between the classifiers before refining.

11.4.3 Multi-label Image Classification

Given an image, the task of multi-label image classification is to predict a set of objects that are presented in the given image. A simple way is to treat this problem as a set of binary classification problems. Each binary classifier predicts whether a certain object is presented in the image or not. However, in the physical world, certain objects frequently occur together. For example, the *tennis ball* and the *tennis racket* frequently co-occur. Capturing the dependencies between the objects is key to the success of the multi-label image classification model. In (Chen et al., 2019c), a graph describing the relations between the objects is learned from the training set, and a graph neural network model is applied to this graph to learn inter-dependent classifiers. These classifiers predict whether objects are presented in a given image or not. Similar to that in Section 11.4.1, the classifiers are denoted by vectors \mathbf{w}_i .

Given an image I , the goal of multi-label image classification is to predict which objects from a candidate set $C = \{c_1, \dots, c_K\}$ are presented in the given image. Hence, a set of K binary classifiers need to be learned to perform the task, which can be denoted as $\{\mathbf{w}_1, \dots, \mathbf{w}_K\}$, with $\mathbf{w}_i \in \mathbb{R}^d$. The dimension d of the classifiers is defined by the image representation $\mathbf{x}_I \in \mathbb{R}^d$, which can be extracted by some pre-trained convolutional neural networks. To learn the object classifiers, which can capture the inter-dependencies between the ob-

jects, a graph neural network model is applied to a graph \mathcal{G} which describes the relations between the objects. In (Chen et al., 2019c), the graph \mathcal{G} consists of the objects as nodes and the connections between them are built according to their co-occurrence in the training data. Specifically, we first count the co-occurrence (i.e., appearing in the same image) of any pair of objects in the training set and get a matrix $\mathbf{M} \in \mathbb{R}^{K \times K}$ where $\mathbf{M}_{i,j}$ denotes the count of co-occurrence of i -th and j -th objects. Then, each row of this matrix is normalized as:

$$\mathbf{P}_i = \mathbf{M}_i / N_i,$$

where \mathbf{P}_i , \mathbf{M}_i denote the i -th row of matrices \mathbf{P} , \mathbf{M} respectively and N_i is the occurrence of the i -th object. To sparsify the matrix \mathbf{P} , we further use a threshold τ to filter the noisy edges as:

$$\mathbf{A}_{i,j} = \begin{cases} 0, & \text{if } \mathbf{P}_{i,j} < \tau; \\ 1, & \text{if } \mathbf{P}_{i,j} \geq \tau \end{cases}$$

The matrix \mathbf{A} can be regarded as the adjacency matrix of the built graph. Once the graph is constructed, the graph neural network model can be applied to learn the classifiers for different objects. Specifically, the classifiers for the objects are the output of the graph neural network model, where the input is the word embeddings for these objects. After obtaining the classifiers $\{\mathbf{w}_1, \dots, \mathbf{w}_K\}$, the classification can be done by mapping the image representation \mathbf{x}_I to a score $\mathbf{w}_i^T \mathbf{x}_I$ that can be utilized for binary classification for each object c_i . Note that the entire process is end-to-end with the image as input and the prediction as output.

11.5 Point Cloud Learning

Point clouds provide flexible geometric representations for 3-D shapes and objects. More formally, a point cloud consists of a set of points $\{v_1, \dots, v_n\}$ where each point contains 3-D geometric coordinates $v_i = (x_i, y_i, z_i)$ representing geometric locations. A point cloud can usually represent a 3-D object or shape. Like graphs, the point clouds are irregular as the points in the set are not ordered and not well-structured. Hence, it is not straightforward to apply classical deep learning techniques such as CNNs for point cloud learning. The topological information in the cloud points is implicitly represented by the distance between the points. To capture the local topology in a cloud point, a graph is built based on the distance between the set of points in the point cloud (Wang et al., 2019k). Specifically, k -nearest neighbors of each point v_i are considered

as its neighbors in the built graph. Then, graph filtering operations are utilized to learn the representations for the points, which can be utilized for downstream tasks. Similar to graphs, there are two types of tasks on point clouds – one is point-focused task such as segmentation, which aims to assign a label for each point and the other is cloud-focused task such as classification, which is to assign a label for the entire point cloud. For the cloud-focused task, pooling methods are required to learn a representation from the point representations for the entire point cloud. Next, we describe the graph filtering operation introduced in (Wang et al., 2019k). For a single point v_i , the process can be expressed as:

$$\mathbf{F}_i^{(l)} = \text{AGGREGATE}(\{h_{\Theta^{(l-1)}}(\mathbf{F}_i^{(l-1)}, \mathbf{F}_j^{(l-1)}) \mid v_j \in \mathcal{N}^{(l-1)}(v_i)\}), \quad (11.10)$$

where AGGREGATE() is an aggregation function such as summation or maximum as introduced in the GraphSAGE-Filter (see Section 5.3.2 for details of GraphSAGE-Filter), the function $h_{\Theta^{(l-1)}}()$ parameterized by $\Theta^{(l)}$ is to calculate the edge information to be aggregated. Various $h_{\Theta^{(l-1)}}()$ functions can be adopted and some examples are listed below:

$$h_{\Theta^{(l-1)}}(\mathbf{F}_i^{(l-1)}, \mathbf{F}_j^{(l-1)}) = \alpha(\mathbf{F}_j^{(l-1)} \Theta^{(l-1)}), \quad (11.11)$$

$$h_{\Theta^{(l-1)}}(\mathbf{F}_i^{(l-1)}, \mathbf{F}_j^{(l-1)}) = \alpha((\mathbf{F}_j^{(l-1)} - \mathbf{F}_i^{(l-1)}) \Theta^{(l-1)}), \quad (11.12)$$

where $\alpha()$ denotes a non-linear activation function. Note that in Eq. (11.10), $\mathcal{N}^{(l-1)}(v_i)$ denotes the set of neighbors of v_i , which is the k-nearest neighbors (including node v_i itself) calculated based on the output features $\mathbf{F}^{(l-1)}$ from the previous layer. Specifically, $\mathcal{N}^{(0)}(v_i)$ is calculated based on $\mathbf{F}^{(0)}$, which are the associated coordinates of the points. Hence, during training, the graph is evolving as the node features are updated.

11.6 Conclusion

This chapter introduces graph neural network models in various computer vision tasks, including visual question answering, skeleton-based human action recognition, zero-shot image recognition, few-shot image recognition, multi-label image recognition, and point cloud learning. For each task, we briefly introduce the task and describe why and how graph neural networks can improve its performance with representative algorithms.

11.7 Further Reading

In addition to the computer vision tasks we introduced in this chapter, graph neural networks have been adopted to enhance many other tasks in computer vision. In (Ling et al., 2019), it is utilized to annotate objects from given images. Graph neural networks are adopted to deal with scene graphs and improve the performance of many tasks related to scene graphs, including scene graph generation (Chen et al., 2019a; Khademi and Schulte, 2020), and scene graph based image captioning (Yang et al., 2019).

12

Graph Neural Networks in Data Mining

12.1 Introduction

Data mining aims to extract patterns and knowledge from large amounts of data (Han et al., 2011). Data from many real-world applications can be inherently represented as graphs. In the Web, relations among social media users such as friendships in Facebook and following relations in Twitter can be denoted as social graphs, and the historical interactions between e-commerce users and items can be modeled as a bipartite graph, with the users and items as the two sets of nodes and their interactions as edges. Roads or road sections in urban areas are often dependent on each other due to spatial relations between them. These spatial relations can be represented by a traffic network where nodes are roads or road sections, and edges indicate the spatial relations. Therefore, graph neural networks have been naturally applied to facilitate various tasks of data mining. In the chapter, we illustrate how GNNs can be adopted for representative data mining tasks, including web data mining, urban data mining, and cybersecurity data mining.

12.2 Web Data Mining

Numerous Web-based applications, such as social media and e-commerce, have produced a massive volume of data. Web data mining is the application of data mining techniques to discover patterns from such data. This section demonstrates how GNNs advance two representative tasks of Web data mining, i.e., social network analysis and recommender systems.

12.2.1 Social Network Analysis

Social networks, which characterize relationships and/or interactions between users, are ubiquitous in the Web, especially social media. Social networks can be naturally modeled as graphs where users in the networks are the nodes, and the relationships and/or interactions are the edges. Graph neural networks have been adopted to facilitate various tasks on social networks such as social influence prediction (Qiu et al., 2018a), political perspective detection (Li and Goldwasser, 2019), and social representation learning (Wang et al., 2019a). Next, we detail some of these tasks.

Social Influence Prediction

In social networks, a person's emotions, opinions, behaviors, and decisions are affected by others. This phenomenon, which is usually referred to as social influence, is widely observed in various physical and/or online social networks. Investigating social influence is important for optimizing advertisement strategies and performing personalized recommendations. In (Qiu et al., 2018a), graph neural networks are adopted to predict local social influence for users in social networks. More specifically, given the local neighborhood of a user and the actions of users in the neighborhood, the goal is to predict whether the user will take the actions in the future or not. For example, in the Twitter platform, the prediction task can be whether a user would retweet posts (the action) on a certain topic given the action status (whether retweet or not) of other closed users (local neighborhood).

The relations between the users in the social network can be modeled as a graph $\mathcal{G} = \{\mathcal{V}, \mathcal{E}\}$, where \mathcal{V} denotes the set of users in the social network and \mathcal{E} denotes the relations between the users. For a node $v_i \in \mathcal{V}$, its local neighborhood is defined as its r -ego network $\mathcal{G}_{v_i}^r$ (Qiu et al., 2018a), which is a subgraph of \mathcal{G} containing all nodes that are within r -hop away from the node v_i . Formally, the node set $\mathcal{V}_{v_i}^r$ and the edge set $\mathcal{E}_{v_i}^r$ for the r -ego network $\mathcal{G}_{v_i}^r$ can be defined as:

$$\begin{aligned}\mathcal{V}_{v_i}^r &= \{v_j \in \mathcal{V} \mid \text{dis}(v_i, v_j) \leq r\}, \\ \mathcal{E}_{v_i}^r &= \{(v_j, v_k) \in \mathcal{E} \mid v_j, v_k \in \mathcal{V}_{v_i}^r\},\end{aligned}$$

where $\text{dis}(v_i, v_j)$ denotes the length of the shortest path between nodes v_i and v_j . Furthermore, for each node $v_j \in \mathcal{V}_{v_i}^r / \{v_i\}$, there is an associated binary action state $s_j \in \{0, 1\}$. For example, in the case of Twitter, the action state $s_j = 1$ if the user v_j retweeted posts on a certain topic, otherwise $s_j = 0$. The action statuses for all nodes in $v_j \in \mathcal{V}_{v_i}^r / \{v_i\}$ can be summarized as $\mathcal{S}_{v_i}^r = \{s_j \mid v_j \in \mathcal{V}_{v_i}^r / \{v_i\}\}$.

The goal of social influence prediction is to predict the action status of node v_i given $\mathcal{G}_{v_i}^r$ and $\mathcal{S}_{v_i}^r$, which is modeled as a binary classification problem.

To predict the action status s_i for node v_i , graph neural network models are applied to the ego-network to learn the node representation for node v_i , which is then utilized to perform the classification. Specifically, the GCN-Filter and the GAT-Filter (see Section 5.3.2 for details on GCN-Filter and GAT-Filter) are adopted as graph filters to build the graph neural networks in (Qiu et al., 2018a). The following features shown in Eq. (12.1) are utilized as the initial input for the graph neural network models.

$$\mathbf{F}_j^{(0)} = [\mathbf{x}_j, \mathbf{e}_j, s_j, ind_j], v_j \in \mathcal{V}_{v_i}^r. \quad (12.1)$$

In Eq. (12.1), \mathbf{x}_j denotes the pre-trained embedding for node v_j learned by methods such as DeepWalk or LINE (see Section 4.2.1 for details on DeepWalk and LINE) over graph \mathcal{G} . The instance normalization trick, which normalizes the embeddings for nodes in $\mathcal{V}_{v_i}^r$, is adopted by (Qiu et al., 2018a) to improve the performance of the model. The vector \mathbf{e}_j contains other node features such as structural features, content features, and demographic features if available. For node v_j , s_j is initialized to be 0 as its action status is unknown. The last element $ind_j \in \{0, 1\}$ is a binary variable indicating whether a node v_j is the ego user, i.e., $ind_j = 1$ only if $v_j = v_i$, otherwise 0.

Social Representation Learning

With the rapid development of social media such as Facebook, more and more services have been provided to users in social networks. For example, users can express their preferences for various movies, sports, and books on Facebook. The availability of these different types of social network services leads to different categories of user behaviors. Users may have similar preferences in one category of behaviors while they have quite different preferences in other behaviors. For example, two users may like the same kind of movies, but they like very different types of sports. To capture users' preference similarities in different behaviors, multiple vectors are utilized to represent each user where each vector corresponds to a specific category of behaviors (Wang et al., 2019a). In detail, for each user, these representations for different behaviors are conditioned on a general representation for this user. To learn these user representations, a graph neural network model is adapted to capture various preference similarities between users in different behaviours (Wang et al., 2019a). Next, we first formally describe the problem setting and then introduce the graph neural network model developed to learn conditional representations.

A social network can be modeled as a graph $\mathcal{G} = \{\mathcal{V}, \mathcal{E}\}$, where $\mathcal{V} = \{v_1, \dots, v_N\}$ represents the set of nodes (social users) and \mathcal{E} denotes the edges

(social relations) connecting them. These relations between users can also be represented by the adjacency matrix of the graph \mathbf{A} . Furthermore, the users also have interactions with items such as movies, books and sports, which are organized to different categories. Specifically, the set of items for a category c (e.g. books) is denoted as \mathcal{I}_c and the interactions between the users and these items are described by an interaction matrix \mathbf{R}^c , where $\mathbf{R}_{i,j}^c = 1$ only when the user v_i has interacted with the j -th item in the category c , otherwise 0. The goal of conditional representation learning is to learn a set of representations for each user v_j , where each conditional representation for a specific category c can capture the social structure information in \mathbf{A} and also the preference in the category c described in \mathbf{R}^c . The representation learning framework is designed based on the MPNN framework as introduced in Section 5.3.2. Its message function $M()$ and the update function $U()$ (for the l -th layer) are described as follows. The message function $M()$ in the MPNN framework generates a message to pass to the center node v_i from its neighbor v_j . To capture various similarities between nodes v_i and v_j in different categories, the representations of these nodes are mapped to different categories as:

$$\mathbf{F}_{j|c}^{(l-1)} = \mathbf{F}_j^{(l-1)} \odot \mathbf{b}_c^{(l-1)},$$

where $\mathbf{b}_c^{(l-1)}$ is a learnable binary mask shared by all nodes to map the input representation $\mathbf{F}_j^{(l-1)}$ to the conditional representation $\mathbf{F}_{j|c}^{(l-1)}$ for the category c . Then, the message from node v_j to node v_i is generated as:

$$\mathbf{F}_{v_j \rightarrow v_i}^{(l-1)} = M(\mathbf{F}_i^{(l-1)}, \mathbf{F}_j^{(l-1)}) = \sum_{c=1}^C \alpha_{i,j|c}^{(l-1)} \cdot \mathbf{F}_{j|c}^{(l-1)},$$

where C denotes the number of categories and $\alpha_{i,j|c}^{(l-1)}$ is the attention score learned as:

$$e_{i,j|c}^{(l-1)} = \mathbf{h}^{(l-1)\top} \text{ReLU} \left(\left[\mathbf{F}_{i|c}^{(l-1)}, \mathbf{F}_{j|c}^{(l-1)} \right] \Theta_a^{(l-1)} \right),$$

$$\alpha_{i,j|c}^{(l-1)} = \frac{\exp \{ e_{i,j|c}^{(l-1)} \}}{\sum_{c=1}^C \exp \{ e_{i,j|c}^{(l-1)} \}},$$

where $\mathbf{h}^{(l-1)}$ and $\Theta_a^{(l-1)}$ are parameters to be learned. The attention mechanism is utilized to ensure that more similar behaviours between users will contribute more when generating the message. After generating the messages, the repre-

sensation for node v_i is updated with the update function as:

$$\mathbf{m}_i^{(l-1)} = \sum_{v_j \in \mathcal{N}(v_i)} \mathbf{F}_{v_j \rightarrow v_i}^{(l-1)}, \quad (12.2)$$

$$\mathbf{F}^{(l)} = U(\mathbf{F}_i^{(l-1)}, \mathbf{m}_i^{(l-1)}) = \alpha([\mathbf{F}_i^{(l-1)}, \mathbf{m}_i^{(l-1)}] \Theta_u^{(l-1)}), \quad (12.3)$$

where $\Theta_u^{(l-1)}$ is the parameters for the update function and $\alpha()$ denotes some activation functions. Note that, after stacking L layers of the above MPNN filtering operations, the final representations \mathbf{F}_i^L can be obtained, which are then mapped to the conditional representation $\mathbf{F}_{i|c}^L$. The final conditional representation $\mathbf{F}_{i|c}^L$ is utilized to recover the interaction information \mathbf{R}^c , which serves as the training objective of the framework. Hence, the learned conditional representations capture both the social structure information and the user-item interaction information for a specific category.

12.2.2 Recommender Systems

Recommender systems have been widely applied to many online services such as e-commerce, video/music streaming services, and social media to alleviate the problem of information overload. Collaborative filtering (CF) (Goldberg et al., 1992; Resnick and Varian, 1997; Goldberg et al., 2001), which utilizes users' historical behavior data to predict their preferences, is one of the most important techniques for developing recommender systems. A key assumption of the collaborative filtering technique is that users with similar historical behaviors have similar preferences. Collaborative filtering approaches usually encode such information into vector representations of users and items, which can reconstruct the historical interactions (Koren et al., 2009; Wang et al., 2019h). When learning these representations, the historical interactions are usually not explicitly utilized but only served as the ground truth for the reconstruction. These historical interactions between users and items can be modeled as a bipartite graph $\mathcal{G} = \{\mathcal{U} \cup \mathcal{V}, \mathcal{E}\}$. Specifically, the set of users can be denoted as $\mathcal{U} = \{u_1, \dots, u_{N_u}\}$, the set of items can be indicated as $\mathcal{V} = \{v_1, \dots, v_{N_v}\}$, and the interactions between them can be represented as $\mathcal{E} = \{e_1, \dots, e_{N_e}\}$, where $e_i = (u_{(i)}, v_{(i)})$ with $u_{(i)} \in \mathcal{U}$ and $v_{(i)} \in \mathcal{V}$. These interactions can also be described by an interaction matrix $\mathbf{M} \in \mathbb{R}^{N_u \times N_v}$, where the i, j -th element of \mathbf{M} indicating the interaction status between the user u_i and item v_j . Specifically, $\mathbf{M}_{i,j}$ can be the rating value user u_i gave to item v_j . It can also be a binary value with $\mathbf{M}_{i,j} = 1$ indicating user u_i interacted with item v_j . With the bipartite graph, the historical interactions can be explicitly utilized to model the representations for users and items by adopting graph neural network models (Berg et al., 2017; Ying et al., 2018b; Wang et al., 2019h).

Furthermore, side information about users and items such as social networks for users and knowledge graphs for items can also be modeled in the form of graphs. It is also incorporated for learning the representations with graph neural network models (Wang et al., 2019b,c,g; Fan et al., 2019). Next, we introduce representative collaborative filtering methods based on graph neural network models.

Collaborative Filtering

Typically, a collaborative filtering approach can be viewed as an encoder-decoder model, where the encoder is to encode each user/item into vector representations and the decoder is to utilize these representations to reconstruct the historical interactions. Hence, the decoder is usually modeled as a regression task (when reconstructing rating) or a binary classification task (when reconstructing the existence of the interactions). Thus, we mainly introduce the encoder part designed based on graph neural network models. The spatial graph filtering operations are adopted to update the representations for users and items. Specifically, for a given user, its representation is updated utilizing the information from its neighbors, i.e., the items he/she has interacted with. Similarly, for a given item, its representation is updated utilizing the information from its neighbors, i.e., the users which have interacted with it. Next, we describe the graph filtering process from the perspective of a given user u_i since the graph filtering process for items is similar. The graph filtering process (for the l -th layer) can be generally described using the MPNN framework as introduced in Section 5.3.2 as follows:

$$\begin{aligned} \mathbf{m}_i^{(l-1)} &= \text{AGGREGATE}\left(\left\{M(\mathbf{u}_i^{(l-1)}, \mathbf{v}_j^{(l-1)}, \mathbf{e}_{(i,j)}) \mid v_j \in \mathcal{N}(u_i)\right\}\right), \\ \mathbf{u}_i^{(l)} &= U(\mathbf{u}_i^{(l-1)}, \mathbf{m}_i^{(l-1)}), \end{aligned} \quad (12.4)$$

where $\mathbf{u}_i^{(l-1)}$, $\mathbf{v}_j^{(l-1)}$ denote the input representations of user u_i and item v_j for the l -th layer, $\mathbf{e}_{(i,j)}$ is the edge information (for example, rating information if it is available), $\mathcal{N}(u_i)$ indicates the neighbors of user u_i , i.e., the items he/she has interacted with and $\text{AGGREGATE}()$, $M()$, $U()$ are the aggregation function, the message function and the update function to be designed, respectively. In (Berg et al., 2017), different aggregation functions are proposed and one example is summation. The message function is designed to incorporate discrete ratings information associated with the interaction as below:

$$M(\mathbf{u}_i^{(l-1)}, \mathbf{v}_j^{(l-1)}) = \frac{1}{\sqrt{|\mathcal{N}(u_i)||\mathcal{N}(v_j)|}} \mathbf{v}_j^{(l-1)} \Theta_{r(u_i,v_j)}^{(l-1)},$$

where $r(u_i, v_j)$ denotes the discrete rating (e.g, 1-5) the user u_i gave to the item v_j and $\Theta_{r(u_i,v_j)}^{(l-1)}$ is shared by all the interactions with this rating. The update

function is implemented as:

$$U(\mathbf{u}_i^{(l-1)}, \mathbf{m}_i^{(l-1)}) = \text{ReLU}(\mathbf{m}_i^{(l-1)} \Theta_{up}^{(l-1)}),$$

where $\Theta_{up}^{(l-1)}$ is the parameter to be learned.

In (Wang et al., 2019h), summation is adopted as the AGGREGATE() function and the message function and the update function are implemented as:

$$M(\mathbf{u}_i^{(l-1)}, \mathbf{v}_j^{(l-1)}) = \frac{1}{\sqrt{|\mathcal{N}(u_i)||\mathcal{N}(v_j)|}} (\mathbf{v}_j^{(l-1)} \Theta_1^{(l-1)} + (\mathbf{u}_i^{(l-1)} \Theta_2^{(l-1)} \odot \mathbf{v}_j^{(l-1)})),$$

$$U(\mathbf{u}_i^{(l-1)}, \mathbf{m}_i^{(l-1)}) = \text{LeakyReLU}(\mathbf{u}_i^{(l-1)} \Theta_3^{(l-1)} + \mathbf{m}_i^{(l-1)}).$$

where $\Theta_1^{(l-1)}$, $\Theta_2^{(l-1)}$ and $\Theta_3^{(l-1)}$ are the parameters to be learned.

Collaborative Filtering with Side Information For Items

Knowledge graphs, which describe the relations between items, are utilized as another resource of information in addition to the historical interactions. Graph neural network models have been adopted to incorporate the information encoded in knowledge graphs while learning representations for items (Wang et al., 2019c,b,g). Specifically, a knowledge graph with the set of items \mathcal{V} as entities can be denoted as $\mathcal{G}_k = \{\mathcal{V}, \mathcal{E}_k, \mathcal{R}\}$, where \mathcal{R} denotes the set of relations in the knowledge graph and each relational edge $e \in \mathcal{E}_k$ can be denoted as $e = (v_i, r, v_j)$ with $r \in \mathcal{R}$. For an item v_i , its connected items in the knowledge graph provide another resource to aggregate information. To aggregate the information while differentiating the importance of various relations, attention mechanism is adopted. Specifically, in (Wang et al., 2019g), the attention score α_{irj} for a relation (v_i, r, v_j) are calculated following the idea of knowledge graph embedding method TransR (Lin et al., 2015) as:

$$\pi(v_i, r, v_j) = (\mathbf{v}_j^{(0)} \Theta_r^{(l-1)})^\top \tanh(\mathbf{v}_i^{(0)} \Theta_r^{(l-1)} + \mathbf{e}_r),$$

$$\alpha_{irj} = \frac{\exp(\pi(v_i, r, v_j))}{\sum_{(r,v_j) \in \mathcal{N}^k(v_i)} \exp(\pi(v_i, r, v_j))},$$

where $\mathbf{v}_i^{(0)}$, \mathbf{e}_r , and $\Theta_r^{(l-1)}$ are the entity embedding, relation embedding, and the transformation matrix learned from TransR (Lin et al., 2015), and $\mathcal{N}^k(v_i)$ denotes the neighbors of v_i in the knowledge graph \mathcal{G}_k . The graph filtering process to update the representation for an item v_i (for the l -th layer) is as:

$$\mathbf{m}_i^{(l-1)} = \sum_{(r,v_j) \in \mathcal{N}^k(v_i)} \alpha_{irj} \mathbf{v}_j^{(l-1)},$$

$$\mathbf{v}_i^{(l)} = U(\mathbf{v}_i^{(l-1)}, \mathbf{m}_i^{(l-1)}) = \text{LeakyReLU}([\mathbf{v}_i^{(l-1)}, \mathbf{m}_i^{(l-1)}] \Theta_{up}^{(l-1)}), \quad (12.5)$$

where $U()$ is the update function and $\Theta_{up}^{(l-1)}$ is the parameter to be learned. The embeddings $\mathbf{v}_i^{(0)}$ learned from TransR are served as the input for the first layer. Note that the entity embeddings, relation embeddings and the transformation matrix learned from TransR are fixed during the propagation described by Eq. (12.5). Hence, the attention score α_{irj} is shared in different graph filter layers. Furthermore, the interactions between users and items are incorporated into the knowledge graph as a special relation *interaction* (Wang et al., 2019g). Specifically, each $e_i = (u_{(i)}, v_{(i)}) \in \mathcal{E}$ is transformed to a relational edge $(u_{(i)}, r, v_{(i)})$ with $r = \textit{interaction}$. Hence, both the user representations and the item representations can be updated utilizing Eq. (12.5).

On the other hand, in (Wang et al., 2019c,b), the attention score is designed to be personalized for each user. In particular, when considering the impact from one entity v_j on another entity v_i , the user we want to recommend items to should also be considered. For example, when recommending movies to users, some users may prefer to movies from certain directors while others might prefer to movies acted by certain actors. Hence, when learning item embeddings specifically for performing recommending items to a user u_k , the attention score for aggregation can be modeled as:

$$\pi(v_i, r, v_j | u_k) = \mathbf{u}_k^T \mathbf{e}_r,$$

where \mathbf{u}_k and \mathbf{e}_r are the user embedding and the relation embedding, respectively. Specifically, this process can be also regarded as inducing a knowledge graph for each user. Note that, in (Wang et al., 2019c,b), only the knowledge graph is explicitly utilized for learning representations, while the historical interactions are only served as the ground-truth for the reconstruction. Hence, the user representation \mathbf{u}_k is just randomly initialized as that in matrix factorization (Koren et al., 2009).

Collaborative Filtering with Side Information For Users

Social networks, which encode the relations/interactions between the users in \mathcal{U} can serve as another resource of information besides the user-item interaction bipartite graph. The social network can be modeled as a graph $\mathcal{G}_s = \{\mathcal{U}, \mathcal{E}_s\}$, where \mathcal{U} is the set of nodes (the users) and \mathcal{E}_s is the set of edges describing the social relations between the users. In (Fan et al., 2019), graph neural network models have been adopted to learn representations for users and items utilizing both information. Specifically, the items' representations are updated by aggregating information from neighboring nodes (i.e., the users that have interacted with the item) in the interaction bipartite graph \mathcal{G} as similar to the GNN models with pure collaborative filtering introduced in the previous sections. For users, the information from the two resources (i.e., the user-item

interaction bipartite graph \mathcal{G} and the social network \mathcal{G}_s) are combined together to generate the user representations as:

$$\mathbf{u}_i^{(l)} = [\mathbf{u}_{i,I}^{(l)}, \mathbf{u}_{i,S}^{(l)}] \Theta_c^{(l-1)},$$

where $\mathbf{u}_{i,I}^{(l)}$ denotes the representation for user u_i learned by aggregating information from the neighboring items in the interaction bipartite graph, and $\mathbf{u}_{i,S}^{(l)}$ indicates its representation learned by aggregating information from neighboring users in the social network. $\Theta_c^{(l-1)}$ is the parameters to be learned. Specifically, $\mathbf{u}_{i,S}^{(l)}$ is updated with the parameter $\Theta_S^{(l-1)}$ as:

$$\mathbf{u}_{i,S}^{(l)} = \sigma \left(\sum_{u_j \in \mathcal{N}^s(u_i)} \mathbf{u}_j^{(l-1)} \Theta_S^{(l-1)} \right),$$

where $\mathcal{N}^s(u_i)$ is the set of neighboring users of user u_i in the social network. Meanwhile, $\mathbf{u}_{i,I}^{(l)}$ is generated with the parameter $\Theta_I^{(l-1)}$ as:

$$\mathbf{u}_{i,I}^{(l)} = \sigma \left(\sum_{v_j \in \mathcal{N}(u_i)} [\mathbf{v}_j^{(l-1)}, \mathbf{e}_{r(i,j)}] \Theta_I^{(l-1)} \right), \quad (12.6)$$

where $\mathcal{N}(u_i)$ is the set of items that user u_i has interacted with and $\mathbf{e}_{r(i,j)}$ is the rating information. In (Fan et al., 2019), the ratings are discrete scores and the rating information $\mathbf{e}_{r(i,j)}$ is modeled as embeddings to be learned.

12.3 Urban Data Mining

The development of sensing technologies and computing infrastructures has enabled us to collect large volumes of data in urban areas such as air quality, traffic, and human mobility. Mining such urban data provides us unprecedented opportunities to tackle various challenging problems introduced by urbanization, such as traffic congestion and air pollution. Next, we demonstrate how GNNs can advance urban data mining tasks.

12.3.1 Traffic Prediction

Analyzing and forecasting the dynamic traffic conditions are of great significance to the planning and construction of new roads and transportation management of smart cities in the new era. In traffic study, the traffic flow data can be usually treated as time series. It consists of traffic flow information such as traffic speed, volume, and density at multiple time steps. Meanwhile,

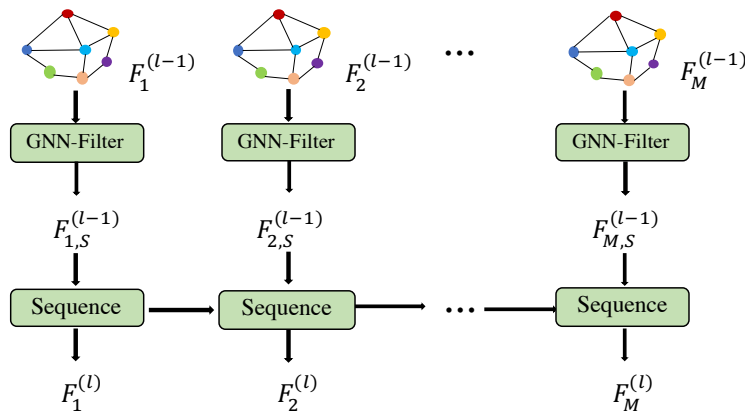

Figure 12.1 A learning layer in a typical framework for traffic prediction

roads or road sections are not independent of each other since there exist spatial relations between them. These spatial relations between roads are typically represented by a traffic network, where roads or road sections are the nodes, and spatial relations are encoded by the edges between them. To achieve better performance for traffic forecasting, it is desired to capture both the spatial and temporal information. Graph neural network models are adopted for spatial relations, while temporal information is captured by sequential modeling methods such as convolutional neural networks, recurrent neural networks, and transformers (Yu et al., 2017; Guo et al., 2019; Wang et al., 2020a). Next, we describe how graph neural networks can capture spatial relations and be incorporated with sequential modeling methods for both the spatial and temporal information.

The traffic network can be denoted as a graph $\mathcal{G} = \{\mathcal{V}, \mathcal{E}\}$, where $\mathcal{V} = \{v_1, \dots, v_N\}$ is the set of nodes (roads or road sections) with N as the number of nodes in the traffic network, and \mathcal{E} is the set of edges describing the spatial relations between nodes. The connections between the nodes can also be described by an adjacency matrix \mathbf{A} . The traffic status information such as traffic speed in the traffic network at a specific time t can be represented at a vector $\mathbf{x}_t \in \mathbb{R}^{N \times d}$, where the i -th row of \mathbf{x}_t is corresponding to node v_i in the traffic network. The task of traffic forecasting is to predict the traffic status for the next H time steps given the observations from the previous M time steps. Specifically, it can be expressed as:

$$(\hat{\mathbf{X}}_{M+1}, \dots, \hat{\mathbf{X}}_{M+H}) = f(\mathbf{X}_1, \dots, \mathbf{X}_M), \quad (12.7)$$

where $f()$ is the model to be learned, and $\hat{\mathbf{X}}_t$ denotes the predicted traffic status at time step t . A typical framework to tackle this problem is first to learn refined node representations at each time step by capturing both spatial and temporal information and then utilize node representations to perform predictions for the future time steps. These representations are refined layer by layer where each learning layer updates the representations by capturing both spatial and temporal relations. The l -th learning layer is shown in Figure 12.1, which consists of two components: 1) the spatial graph filtering operation to capture the spatial relations; and 2) the sequence model to capture the temporal relations. The spatial graph filtering operation is applied to node representations in each time step as follows:

$$\mathbf{F}_{t,S}^{(l)} = \text{GNN-Filter}(\mathbf{F}_t^{(l-1)}, \mathbf{A}), t = 1, \dots, M, \quad (12.8)$$

where $\mathbf{F}_t^{(l-1)}$ is the node representations at time step t after the $(l-1)$ -th learning layer while $\mathbf{F}_{t,S}^{(l)}$ denotes the node representations after the l -th spatial graph filtering layer, which will serve as the input for the l -th sequence model. Note that the GNN-Filter is shared by all time steps. Different graph filtering operations can be adopted. For example, in (Yu et al., 2017), the GCN-Filter (see details on GCN-Filter in Section 5.3.2) is adopted while in (Guo et al., 2019; Wang et al., 2020a), attention mechanism is utilized to enhance the graph filtering operation. The output of the spatial graph filtering operation is a sequence, i.e., $(\mathbf{F}_{1,S}^{(l)}, \dots, \mathbf{F}_{M,S}^{(l)})$, which will be fed into a sequence model to capture the temporal relations as:

$$\mathbf{F}_1^{(l)}, \dots, \mathbf{F}_M^{(l)} = \text{Sequence}(\mathbf{F}_{1,S}^{(l)}, \dots, \mathbf{F}_{M,S}^{(l)}), \quad (12.9)$$

where the output $\mathbf{F}_1^{(l)}, \dots, \mathbf{F}_M^{(l)}$ will in turn serve as the input to the next spatial graph filtering layer. Various sequence modeling methods can be adopted as the Sequence() function. For example, in (Yu et al., 2017), 1-D convolutional neural networks are adopted to deal with the temporal information. GRU model and the transformer are adopted in (Wang et al., 2020a) to capture the temporal relations. The final representations $\mathbf{F}_1^{(L)}, \dots, \mathbf{F}_M^{(L)}$ are obtained by applying L learning layers as described above and then utilized to predict the traffic status in the future. Note that $\mathbf{F}_1^{(0)}, \dots, \mathbf{F}_M^{(0)}$ can be initialized with node information such as traffic status $\mathbf{X}_1, \dots, \mathbf{X}_M$.

12.3.2 Air Quality Forecasting

Air pollution has raised public concerns due to its adverse effects on the natural environment and human health. Hence, it is important to forecast the air quality, which can provide public guidance for people affected by this issue. The

air quality forecasting problem can be formulated in a spatial-temporal form as the air quality in nearby locations is related, and the air quality in one location is temporally evolving. The spatial relations between different locations can be denoted as a graph $\mathcal{G} = \{\mathcal{V}, \mathcal{E}\}$, where the locations are the nodes, and the edges describe the geographic relations between nodes. The air quality status includes different indices such as $\text{PM}_{2.5}$, PM_{10} , NO_2 , SO_2 , O_3 , and CO . The air quality status measured at time t for all locations in \mathcal{V} is denoted as \mathbf{X}_t , where the i -th row of \mathbf{X}_t is corresponding to the air quality status of location $v_i \in \mathcal{V}$. In the task of air quality forecasting, we aim to predict air quality status for all locations in a future time slot given the historical status. Generally, we denote the air quality status we plan to predict at time t as \mathbf{Y}_t , where the i -th row is corresponding to the i -th location v_i . Then, the air quality forecasting problem can be formulated as:

$$(\mathbf{Y}_{M+1}, \dots, \mathbf{Y}_{M+H}) = f(\mathbf{X}_1, \dots, \mathbf{X}_M), \quad (12.10)$$

where $(\mathbf{X}_1, \dots, \mathbf{X}_M)$ is the observed air quality status from the previous M steps and $(\mathbf{Y}_{M+1}, \dots, \mathbf{Y}_{M+H})$ is the air quality status we aim to forecast in the next H steps. The framework introduced in Section 12.3.1 can be used to forecast air quality. In (Qi et al., 2019) where the goal is to predict only $\text{PM}_{2.5}$, GCN-Filter is utilized to capture the spatial relations between different locations while an LSTM model is adopted to capture the temporal relations.

12.4 Cybersecurity Data Mining

With the growing use of the Internet, new vulnerabilities and attack schemes are discovering every day for computer and communication systems. These changes and dynamics have posed tremendous challenges to traditional security approaches. Data mining can discover actionable patterns from data, and thus it has been employed to tackle these cybersecurity challenges. Given that cybersecurity data can be denoted as graphs, GNNs have facilitated various aspects of cybersecurity data such as spammer detection and fake news detection.

12.4.1 Malicious Account Detection

Cyber attackers aim to attack large-scale online services such as email systems, online social networks, e-commerce, and e-finance platforms by creating malicious accounts and propagating spamming messages. These attacks are harmful to these online services and could even cause a huge financial loss in certain

circumstances. Hence, it is important to detect these malicious accounts effectively. Graph neural network models have been utilized to facilitate the task of malicious account detection. In (Liu et al., 2018b), two patterns on the malicious accounts are observed. First, malicious accounts from the same attacker tend to signup or login to the same device or a common set of devices due to the attackers' limited resources. Second, malicious accounts from the same group tend to behave in batches, i.e., they signup or login in a burst of time. A graph between accounts and devices is built based on these two observations, and the malicious account detection task is treated as a binary semi-supervised classification task on this graph, where the goal is to tell whether an account is malicious or not. Next, we first describe the graph construction process and then discuss how graph neural network models can be leveraged for malicious account detection.

Graph Construction

There are two types of objects involving in this task: accounts and devices. The concept of “device” can be very general, including IP addresses or phone numbers. We denote the set of types of devices as \mathcal{D} . Assume that there are N nodes, including accounts and devices. An edge is observed between an account and a device if an account has activities (e.g., signups and logins) in this specific device. This constructed graph can be denoted as $\mathcal{G} = \{\mathcal{V}, \mathcal{E}\}$, where \mathcal{V} and \mathcal{E} are the node and edge sets, respectively. The relations between these nodes in \mathcal{V} can also be described by an adjacency matrix \mathbf{A} . $|\mathcal{D}|$ subgraphs $\{\mathcal{G}^{(d)} = \{\mathcal{V}, \mathcal{E}^{(d)}\}\}$ are extracted from the graph \mathcal{G} , where $\mathcal{G}^{(d)}$ is the subgraph consisting of all nodes but only edges involving type $d \in \mathcal{D}$ devices. We use $\mathbf{A}^{(d)}$ to denote the adjacency matrix of the subgraph $\mathcal{G}^{(d)}$. A feature vector $\mathbf{x}_i \in \mathbb{R}^{p+|\mathcal{D}|}$ is associated with each node $v_i \in \mathcal{V}$. Specifically, the first p elements in \mathbf{x}_i denote the frequency of activities in p consecutive periods. For example, in (Liu et al., 2018b), $p = 168$ and each time period is 1 hour. The last $|\mathcal{D}|$ elements in \mathbf{x}_i indicate the type of the device. If the node is a device, it is a one-hot indicator of its type, and it is all 0 if it is an account.

Malicious Account Detection with Graph Neural Networks

Graph neural networks are utilized to refine the node features, which are then leveraged to perform malicious account detection (or the binary classification). The formulation of the semi-supervised classification task is the same as that in Section 5.5.1. Hence, we mainly introduce the process of learning node features. More specifically, we introduce a graph filter dedicated to this task as

follows:

$$\mathbf{F}^{(l)} = \sigma \left(\mathbf{X}\boldsymbol{\Theta}^{(l-1)} + \frac{1}{|\mathcal{D}|} \sum_{d \in \mathcal{D}} \mathbf{A}^{(d)} \mathbf{F}^{(l-1)} \boldsymbol{\Theta}_{(d)}^{(l-1)} \right),$$

where \mathbf{X} denotes the input features of all nodes, $\mathbf{F}^{(l)}$ is the hidden representations after l -th graph filtering layer with $\mathbf{F}^{(0)} = \mathbf{0}$, and $\{\boldsymbol{\Theta}^{(l-1)}, \boldsymbol{\Theta}_{(d)}^{(l-1)}\}$ are parameters to be learned. Note that the graph filtering operation differs from those introduced in Section 5.3.2, as it utilizes the input features \mathbf{X} in each graph filtering layer. The goal is to ensure that the account activity patterns encoded by \mathbf{X} can be better preserved. After L graph filtering layers, these features are used to perform the binary classification. Since the malicious accounts (from the same attacker) tend to connect with the same set of device nodes, the graph filtering process will enforce them to have similar features. Meanwhile, the activity patterns of the accounts are captured by the input feature \mathbf{X} . Thus, aforementioned two patterns can be captured by the graph neural network models, which benefits the task of malicious account detection.

12.4.2 Fake News Detection

Online social media has become one of the critical sources for people to obtain news due to its easy access and instant dissemination. While being extremely convenient and efficient, these platforms also significantly increase the risk of propagating fake news. Fake news could lead to many negative consequences or even severe societal issues and substantial financial loss. Hence, it is immensely vital to detect fake news and prevent it from propagating through social media. Substantial empirical evidence has shown that fake news has different propagation patterns from real news in online social media (Vosoughi et al., 2018), which can be utilized to facilitate the task of fake news detection. In (Monti et al., 2019), each story is modeled as a graph, which characterizes its diffusion process and social relations in the social network platform such as Twitter. Then, the task of fake news detection is treated as a binary graph classification task, and graph neural network models are adopted to improve its performance. Next, we describe the process to form the graphs for the stories and then briefly introduce the graph neural network model designed for this task.

Graph Construction

We take the news diffusion process in Twitter as an example to illustrate the process of graph construction for each story. Given a story u with its corresponding tweets $\mathcal{T}_u = \{t_u^{(1)}, \dots, t_u^{(N_u)}\}$ which mention u , the story u is described

by a graph \mathcal{G}_u . The graph \mathcal{G}_u consists of all the tweets in \mathcal{T}_u as nodes, while the edges either describe the news diffusion process or the social relations between the authors of these tweets. We next describe the two types of edges in this graph \mathcal{G}_u . We use $a(t_u^{(i)})$ to denote the author of a given tweet $t_u^{(i)}$. The first type of edges between the tweets is defined based on their authors, i.e., an edge exists between two tweets $t_u^{(i)}$ and $t_u^{(j)}$ if the $a(t_u^{(i)})$ follows $a(t_u^{(j)})$ or $a(t_u^{(j)})$ follows $a(t_u^{(i)})$. The second type of edges is based on the diffusion process of this news u through the social network, i.e., an edge exists between two tweets $t_u^{(i)}$ and $t_u^{(j)}$ if the news u spreads from one to the other. The news diffusion path is estimated via (Vosoughi et al., 2018), which jointly considers the timestamps of the tweets and the social connections between their authors. For convenience, we assume that the superscript of a tweet $t_u^{(i)}$ indicates its timestamp information, i.e., all tweets with superscripts smaller than i are created before $t_u^{(i)}$ while the ones with superscripts larger than i are created after $t_u^{(i)}$. Then, for a given tweet $t_u^{(i)}$, we estimate its spreading path as:

- If $a(t_u^{(i)})$ follows at least one author of the previous tweets $\{a(t_u^{(1)}), \dots, a(t_u^{(i-1)})\}$, we estimate that the news spreads to $t_u^{(i)}$ from the very last tweet whose author is followed by $a(t_u^{(i)})$.
- If $a(t_u^{(i)})$ does not follow any authors of the previous tweets $\{a(t_u^{(1)}), \dots, a(t_u^{(i-1)})\}$, then we estimate that the news spreads to $t_u^{(i)}$ from the tweet in $\{t_u^{(1)}, \dots, t_u^{(i-1)}\}$ whose author has the largest number of followers.

Fake News Detection as Graph Classification

We can build a graph for each story u as described above, and then we treat the task of fake news detection as a binary graph classification task. The graph neural network framework for graph classification is introduced in Section 5.5.2, which can be directly applied to this task. Specifically, in (Monti et al., 2019), two graph filtering layers are stacked together to refine the node features, which are followed by a graph mean-pooling layer to generate a graph representation. The generated graph representation is then utilized to perform the binary classification.

12.5 Conclusion

This chapter describes how graph neural network models can be applied to advance various sub-fields of data mining, including Web data mining, urban data mining, and cybersecurity data mining. In Web data mining, we introduce representative methods using GNNs for social network analysis and recommender systems. In urban data mining, we discuss GNNs based models for

traffic prediction and air quality prediction. In cybersecurity data mining, we provide representative algorithms built on GNNs to advance malicious account detection and fake news detection.

12.6 Further Reading

There are more existing methods than the representative ones we have detailed for the data mining tasks introduced in this chapter. For example, social information is encoded by graph neural networks to predict the political perspective (Li and Goldwasser, 2019), and graph neural networks are employed for fraud detection (Wang et al., 2019d; Liu et al., 2020), and anti-money laundering (Weber et al., 2019). In addition, graph neural networks have been utilized to help more data mining tasks, such as community detection (Chen et al., 2017; Shchur and Günnemann, 2019) and anomaly detection (Wang et al., 2020b; Chaudhary et al., 2019).

13

Graph Neural Networks in Biochemistry and Healthcare

13.1 Introduction

Graphs have been widely adopted to represent data in computational biochemistry and healthcare. For example, molecules and chemical compounds can be naturally denoted as graphs with atoms as nodes and bonds connecting them as edges. The protein-protein interactions (PPIs), which record the physical contacts established between two or more proteins, can be captured as a graph. Furthermore, in the drug industry, drug-drug interactions (DDIs), which describe the adverse outcomes when using certain combinations of drugs for complex diseases, can also be represented as graphs. Given the powerful capacity in learning graph representations, graph neural network models have been adopted to facilitate many biochemistry and healthcare applications, including drug development and discovery, multi-view drug similarity integration, polypharmacy side effect prediction, medication recommendation, and disease prediction. In this chapter, we discuss GNN models for representative applications in biochemistry and healthcare.

13.2 Drug Development and Discovery

Graph neural networks have been adopted to advance many tasks that are important for drug development and discovery. Examples of these tasks include: 1) molecule representation learning, which can facilitate downstream tasks such as molecule property prediction and therefore can help narrow down search space to find more promising candidates with proper properties; 2) molecule graph generation, which aims to generate molecules with desired properties; 3) drug-target binding affinity prediction, which is to predict the drug-target interaction strength and thus can benefit the new drug development

and drug re-purposing; and 4) protein interface prediction, which targets on predicting the interaction interface of proteins and thus can allow us to understand molecular mechanisms. Next, we introduce the applications of graph neural networks in molecule representation learning, drug-target binding affinity prediction, and protein interface prediction. Note that we have introduced representative methods that are partially based on graph neural network models to generate molecular graphs in Section 9.4.2 and Section 9.5.2.

13.2.1 Molecule Representation Learning

It is important to predict the properties of novel molecules for applications in material designs and drug discovery. Deep learning methods have been adopted to perform the predictions on molecular data. Typically, deep learning methods such as feed-forward networks and convolutional neural networks cannot be directly applied to molecular data as the molecule can be of arbitrary size and shape. Hence, the prediction procedure usually consists of two stages: 1) feature extraction: extracting molecule fingerprint, a vector representation encoding the structure information of the molecule; and 2) property prediction: performing prediction with deep learning methods using the extracted fingerprint as input. Traditionally the molecular fingerprint is extracted using some non-differentiable off-the-shelf fingerprint software without guidance from the downstream prediction task. Thus, these extracted representations might not be optimal for the downstream tasks. In (Duvenaud et al., 2015), an end-to-end framework is proposed to perform the predictions, where graph neural networks are adopted to learn the molecular fingerprints in a differentiable way. Specifically, a molecule can be represented as a graph $\mathcal{G} = \{\mathcal{V}, \mathcal{E}\}$ where nodes are the atoms and edges represent the bonds between these atoms. Thus, the task of molecular property prediction can be regarded as graph classification or graph regression, which requires to learn graph-level representations. Note that in the context of molecules, these representations are called molecular fingerprints. Hence, the graph neural network model adopted to perform this task consists of both graph filtering and graph pooling layers (see general framework in Chapter 5). Specifically, in (Duvenaud et al., 2015), a global pooling method is adopted. Next, we first introduce the graph filtering layers and then introduce the global pooling layer to obtain the molecular fingerprint. For a node $v_i \in \mathcal{V}$, the graph filtering operation (in the l -th layer) can be described as:

$$\mathbf{F}_i^{(l)} = \sigma \left(\left[\mathbf{F}_i^{(l-1)} + \sum_{v_j \in \mathcal{N}(v_i)} \mathbf{F}_j^{(l-1)} \right] \Theta_{|\mathcal{N}(v_i)|}^{(l-1)} \right), \quad (13.1)$$

where $\Theta_{|\mathcal{N}(v_i)|}^{(l-1)}$ is a transformation matrix depending on the size of the neighborhood $|\mathcal{N}(v_i)|$ of node v_i . Thus, the total number of transformation matrices in each layer is determined by the number of neighborhood size. In organic molecules, an atom can have up to 5 neighbors, and hence there are 5 transformation matrices in each layer. The molecular fingerprint $\mathbf{f}_{\mathcal{G}}$ for a molecule \mathcal{G} can be obtained by the following global pooling operation:

$$\mathbf{f}_{\mathcal{G}} = \sum_{l=1}^L \sum_{v_i \in \mathcal{V}} \text{softmax}(\mathbf{F}_i^{(l)} \Theta_{pool}^{(l)}), \quad (13.2)$$

where L denotes the number of graph filtering layers, and $\Theta_{pool}^{(l)}$ is utilized to transform the node representations learned in the l -th layer. The global pooling method in Eq. (13.2) aggregates the information from node representations learned in all the graph filtering layers. The obtained molecule fingerprint $\mathbf{f}_{\mathcal{G}}$ can then be adopted for downstream tasks such as property prediction. Both the graph filtering process in Eq. (13.1) and the pooling process in Eq. (13.2) are guided by the given downstream task such as molecule property prediction (Liu et al., 2018a). In fact, besides the method we introduced above, any graph neural networks designed for learning graph level-representations can be utilized to learn the molecular representations. Specifically, we can compose a graph neural network model with graph filtering layers and graph pooling layers, as introduced in Chapter 5. In particular, the MPNN-Filter discussed in Section 5.3.2 was introduced under the context of the molecular representation learning (Gilmer et al., 2017).

13.2.2 Protein Interface Prediction

Proteins are chains of amino acids with biochemical functions (Fout et al., 2017) as shown in Figure 13.2. As shown in Figure 13.1, an amino acid is an organic compound. It contains amine ($-\text{NH}_2$), carboxyl ($-\text{COOH}$) functional groups and a side chain (R group), which is specific to each amino acid. To perform their functions, proteins need to interact with other proteins. Predicting the interface where these interactions occur is a challenging problem with important applications in drug discovery and design (Fout et al., 2017). The protein interaction interface consists of interacting amino acid residues and nearby amino acid residues in the interacting proteins. Specifically, in (Afsar Minhas et al., 2014), two amino acid residues from different proteins are considered to be a part of the interface if any non-hydrogen atom in one amino acid residue is within 6\AA of any non-hydrogen atom in the other amino acid residue. Therefore, the protein interface prediction problem can be modeled as

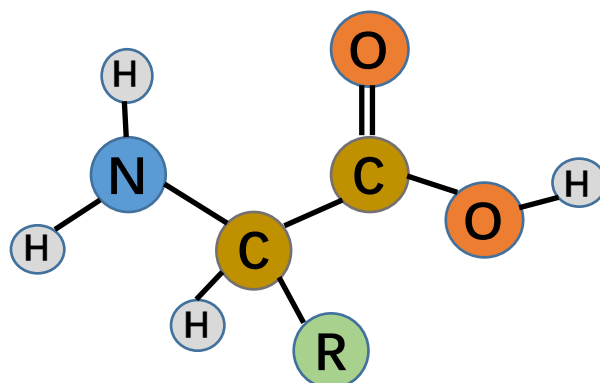

Figure 13.1 An illustrative example of amino acids.

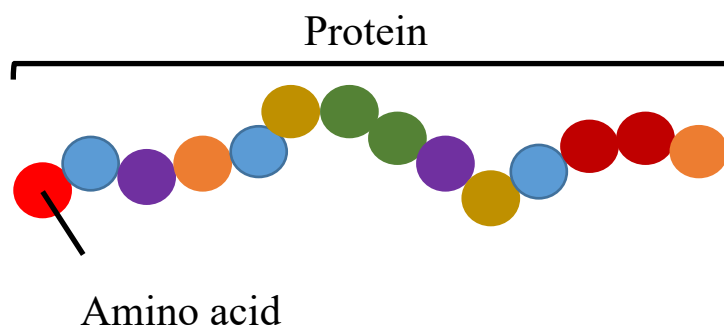

Figure 13.2 A protein consists of a chain of amino acids

a binary classification problem where a pair of amino acid residues from different proteins are served as input. In (Fout et al., 2017), a protein is modeled as a graph. In the graph, amino acid residues in the protein are treated as nodes, and relations between them are defined as edges. Then, graph neural network models are employed to learn node representations, which are then utilized for classification. Next, we describe how proteins are treated as graphs and then introduce the approach to perform the protein interface prediction.

Representing Proteins as Graphs

A protein can be represented as a graph $\mathcal{G} = \{\mathcal{V}, \mathcal{E}\}$. In detail, each amino acid residue in the protein is treated as a node. The spatial relations between the

amino acid residues are utilized to build the edges between them. Specifically, each amino acid residue node is connected to k closest amino acid residues determined by the mean distance between their atoms. Each node and edge in the graph are associated with some features. Specifically, features for node $v_i \in \mathcal{V}$ are denoted as \mathbf{x}_i and features for an edge (v_i, v_j) are represented as \mathbf{e}_{ij} .

Protein Interface Prediction

Given a pair of amino acid residues, one from a ligand protein $\mathcal{G}_l = \{\mathcal{V}_l, \mathcal{E}_l\}$ and the other one from a receptor protein $\mathcal{G}_r = \{\mathcal{V}_r, \mathcal{E}_r\}$, the task of protein interface prediction is to tell whether these two residues are in the protein interface. It is treated as a binary classification problem where each sample is a pair of amino acid residues (v_l, v_r) with $v_l \in \mathcal{V}_l$ and $v_r \in \mathcal{V}_r$. Graph filtering operations are applied to \mathcal{G}_l and \mathcal{G}_r to learn the node representations and then the node representations for v_l and v_r are combined to obtain a unified representation for this pair, which is then utilized for the classification by fully-connected layers. A graph filter similar to GCN-Filter (see details of GCN-Filter in Section 5.3.2) is adopted to learn the node representations as (for l -th layer):

$$\mathbf{F}_i^{(l)} = \sigma \left(\mathbf{F}_i^{(l-1)} \Theta_c^{(l-1)} + \frac{1}{|\mathcal{N}(v_i)|} \sum_{v_j \in \mathcal{N}(v_i)} \mathbf{F}_j^{(l-1)} \Theta_N^{(l-1)} + \mathbf{b} \right),$$

where $\Theta_c^{(l-1)}$ and $\Theta_N^{(l-1)}$ are learnable matrices specific to the centering node and the neighboring node respectively, and \mathbf{b} is the bias term. Furthermore, to incorporate the edge features, the following graph filtering operation is proposed in (Fout et al., 2017):

$$\mathbf{F}_i^{(l)} = \sigma \left(\mathbf{F}_i^{(l-1)} \Theta_c^{(l-1)} + \frac{1}{|\mathcal{N}(v_i)|} \sum_{v_j \in \mathcal{N}(v_i)} \mathbf{F}_j^{(l-1)} \Theta_N^{(l-1)} + \frac{1}{|\mathcal{N}(v_i)|} \sum_{v_j \in \mathcal{N}(v_i)} \mathbf{e}_{ij} \Theta_E^{(l-1)} + \mathbf{b} \right),$$

where \mathbf{e}_{ij} denotes the edge features for the edge (v_i, v_j) and $\Theta_E^{(l-1)}$ is the learnable transformation matrix for edges. Note that the edge features are fixed during the training process.

13.2.3 Drug-Target Binding Affinity Prediction

The development of a new drug is usually time-consuming and costly. The identification of drug-target interactions (DTI) is vital in the early stage of the drug development to narrow down the search space of candidate medications. It can also be used for drug re-purposing, which aims to identify new targets for existing or abandoned drugs. The task of drug-target binding affinity prediction

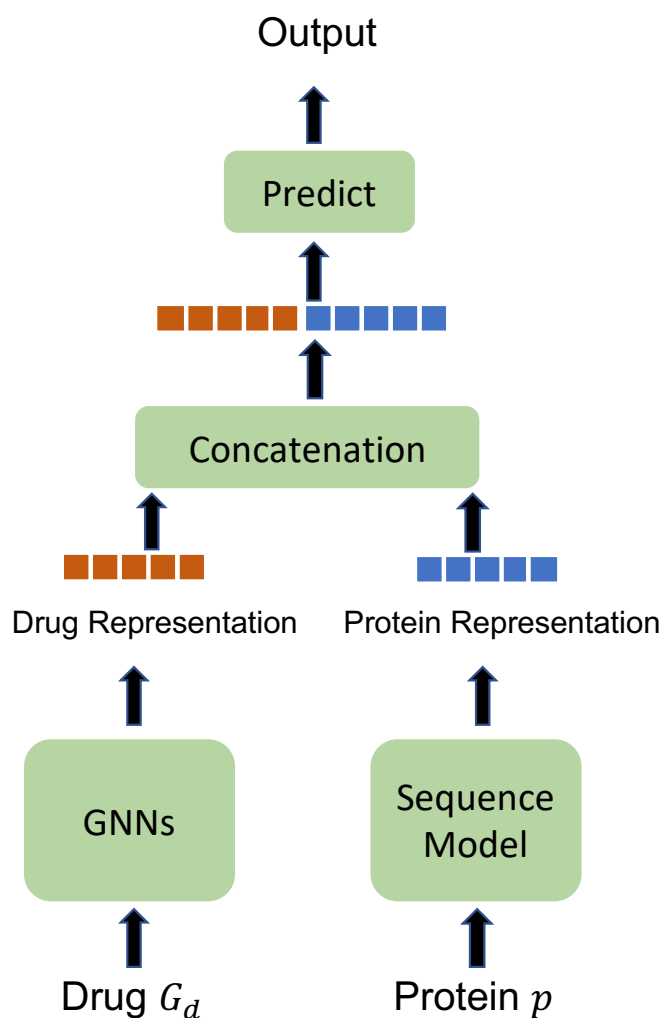

Figure 13.3 A general framework for drug-target binding affinity prediction

is to infer the strength of the binding between a given drug-target pair. It can be considered as a regression task. There are mainly four types of targets, i.e., protein, disease, gene, and side effect, frequently involved in the task of drug-target interaction prediction. In this section, we use protein as the target to illustrate how graph neural network models can be employed to facilitate this task.

A drug-protein pair is denoted as (\mathcal{G}_d, p) , with \mathcal{G}_d, p denoting the drug and protein, respectively. The drug \mathcal{G}_d is represented as a molecular graph with atoms as nodes and the chemical bonds as edges. The protein can be denoted as either a sequence or a graph. In (Nguyen et al., 2019), the proteins are represented as sequences of amino acids, which we adopt to illustrate the framework for drug-target binding affinity prediction. An overview of a general framework for drug-target binding affinity prediction is shown in Figure 13.3. In this framework, the drug \mathcal{G}_d is fed into a graph neural network model to learn a graph-level drug representation, and the protein is fed into a sequence model to learn a protein representation. These two representations are concatenated to generate a combined representation for the pair, and it is then leveraged to predict the drug-target binding affinity. The graph neural network model consists of graph filtering and graph pooling layers, as introduced in Chapter 5. The GNN models introduced in Section 13.2.1 for molecule representation learning can also be used to learn the drug representation. Sequence models such as 1-D CNN, LSTM, and GRU, can learn the protein representation. Furthermore, if we model the protein as a graph, we can also use the GNNs to replace the sequence model in Figure 13.3 to learn its representation.

13.3 Drug Similarity Integration

With the rapid development of technology, drug data from multiple sources are collected for computational drug discovery research, and drug safety studies. For example, the structural information of drugs can be extracted by chemical fingerprints software and drug indication information is extracted from the packages of drugs (Kuhn et al., 2016). To better facilitate the downstream task such as drug-drug interaction (DDI) prediction, it is necessary to fuse the drug data from multiple sources, as they contain information of drugs from various perspectives. These multiple data sources of drugs may encode different similarities between drugs and thus have different levels of association with targeting outcomes. For example, drugs' structural similarity could have more impact on their interaction profiles than drugs' indication similarity. In (Ma et al., 2018c), an attentive algorithm based on graph neural networks is proposed to fuse the drug similarity information from various sources with the guidance of the downstream tasks. Specifically, each source of drug features is regarded as a view in (Ma et al., 2018c). For view $t \in \{1, \dots, T\}$, the features for all nodes in this view are denoted as a matrix $\mathbf{X}_t \in \mathbb{R}^{N \times d_t}$, where N is the number of drugs and d_t is the dimension of the features in this view. Furthermore, the similarity information of the drugs in this view is encoded

into a similarity matrix $\mathbf{A}_t \in \mathbb{R}^{N \times N}$. The goal of multi-view drug similarity integration is to fuse the features and similarity matrices from different views to generate integrated features $\mathbf{Z} \in \mathbb{R}^{N \times d}$ and similarity matrix \mathbf{A} across all views.

The similarity matrices from different views are combined as follows:

$$\mathbf{A} = \sum_{t=1}^T \text{diag}(\mathbf{g}_t) \mathbf{A}_t, \quad (13.3)$$

where $\mathbf{g}_t \in \mathbb{R}^N$ is the attention scores learned as:

$$\begin{aligned} \mathbf{g}'_t &= \Theta_t \mathbf{A}_t + \mathbf{b}_t, \forall t = 1, \dots, T, \\ [\mathbf{g}_1, \dots, \mathbf{g}_T] &= \text{softmax}([\mathbf{g}'_1, \dots, \mathbf{g}'_T]), \end{aligned}$$

where $\Theta_t, \mathbf{b}_t \in \mathbb{R}^N$ are parameters to be learned and the softmax function is applied to each row. With the fused similarity matrix \mathbf{A} , the fused features are obtained by applying a GNN-Filter on the multi-view features as:

$$\mathbf{Z} = \alpha(\text{GNN-Filter}(\mathbf{A}, \mathbf{X})), \quad (13.4)$$

where $\mathbf{X} = [\mathbf{X}_1, \dots, \mathbf{X}_T]$ is the concatenation of the features from different views. Specifically, the GCN-Filter (see details about GCN-Filter in Section 5.3.2) is adopted in (Ma et al., 2018c) and $\alpha()$ is the softmax function (applied row-wisely). A decoder is then used to reconstruct \mathbf{X} from \mathbf{Z} expecting that the fused representations contain as much information from \mathbf{X} as possible. The decoder is also modeled by a GNN-Filter as:

$$\mathbf{X}' = \alpha(\text{GNN-Filter}(\mathbf{A}, \mathbf{Z})), \quad (13.5)$$

where the GCN-Filter is again adopted as the graph filter and sigmoid function is adopted as the non-linear activation function $\alpha()$ in (Ma et al., 2018c). The reconstruction loss is as:

$$\mathcal{L}_{ed} = \|\mathbf{X} - \mathbf{X}'\|^2.$$

The parameters in Eq. (13.3), Eq. (13.4) and Eq. (13.5) can be learned by minimizing the reconstruction loss. Furthermore, the fused representations \mathbf{Z} can be used for downstream tasks and the gradient from the downstream tasks can also be leveraged to update the parameters in Eq. (13.3), Eq. (13.4) and Eq. (13.5).

13.4 Polypharmacy Side Effect Prediction

A lot of complex diseases can not be treated by a single drug. A promising strategy to combat these diseases is polypharmacy. It means using a com-

combination of several drugs to treat patients. However, a major adverse consequence of polypharmacy is that it is highly risky to introduce side effects due to drug-drug interactions. Hence, it is important to predict the side effects of polypharmacy when adopting novel drug combinations to treat diseases. The polypharmacy side effect prediction task is not only to predict whether a side effect exists between a pair of drugs but also to tell what type of side effect it is. Exploratory analysis in (Zitnik et al., 2018) shows that co-prescribed drugs tend to have more target proteins in common than random drug pairs, which indicates that the interactions between drug and target proteins are important for polypharmacy modeling. Hence, the interactions between drug and target proteins and the interactions between the target proteins, are incorporated for polypharmacy side effect prediction in (Zitnik et al., 2018). In detail, a multi-modal graph is built on the drug-drug interactions (polypharmacy side effects), the drug-protein interactions and the protein-protein interactions. The task of polypharmacy prediction is thus modeled as a multi-relational link prediction task over the multi-modal graph. The goal is to predict whether a link exists between a pair of drugs and then what type of the link it is if existing. Graph neural network models have been adopted to learn the node representations, which are then used to perform the prediction. Next, we first describe how to construct the multi-modal graph and then introduce the framework to perform the polypharmacy side effect prediction.

Multi-modal Graph Construction

As shown in Figure 13.4, a two-layer multi-modal graph with two types of nodes (drugs and proteins) are built upon three different interactions including drug-drug interactions, drug-protein interactions, and protein-protein interactions. Drug-drug interactions encode the observed polypharmacy side effects. For example, in Figure 13.4, the drug Doxycycline (node D) and drug Ciprofloxacin (node C) are connected by the relation r_2 (bradycardia side effect), which indicates that taking a combination of these two drugs likely leads to the bradycardia side effect. The drug-protein interactions describe the proteins that a drug targets on. For example, in Figure 13.4, the drug Ciprofloxacin (node C) targets on 4 proteins. The protein-protein interactions encode the physical binding relations between proteins in humans. In particular, this two-layer multi-modal graph can be denoted as $\mathcal{G} = \{\mathcal{V}, \mathcal{E}, \mathcal{R}\}$. In \mathcal{G} , \mathcal{V} is the set of nodes consisting of drugs and proteins, \mathcal{E} denotes the edges. Each $e \in \mathcal{E}$ is in the form of $e = (v_i, r, v_j)$ with $r \in \mathcal{R}$ and \mathcal{R} is the set of relations, which includes: 1) protein-protein interactions, 2) a target relationship between a drug and a protein; and 3) various types of side effects between drugs.

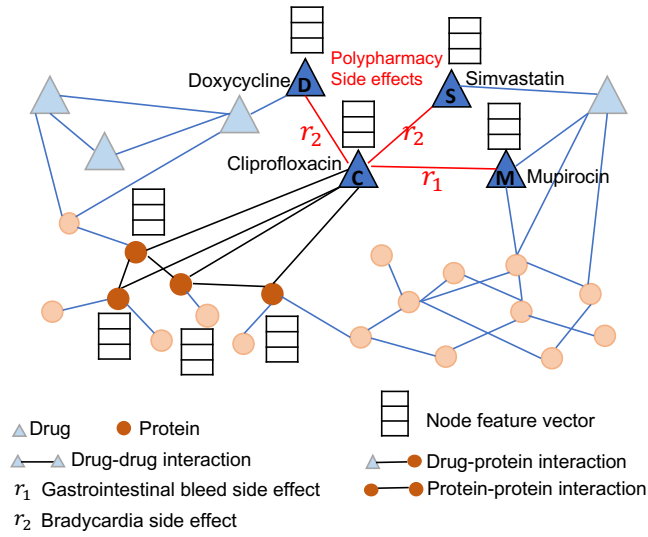

Figure 13.4 An illustrative example of the two-layer multi-modal graph with drug-drug interactions, drug-protein interactions, and protein-protein interactions

Polypharmacy Side Effect Prediction

The task of polypharmacy side effect prediction is modeled as a relational link prediction task on \mathcal{G} . In particular, given a pair of drugs $\{v_i, v_j\}$, we want to predict how likely an edge $e_{ij} = (v_i, r, v_j)$ of type $r \in \mathcal{R}$ exists between them. In (Zitnik et al., 2018), graph filtering operations are adopted to learn the node representations, which are then utilized to perform the relational link prediction. Specifically, the graph filtering operation designed for knowledge graph (Schlichtkrull et al., 2018) is adapted to update the node representations as:

$$\mathbf{F}_i^{(l)} = \sigma \left(\sum_{r \in \mathcal{R}} \sum_{v_j \in \mathcal{N}_r(v_i)} c_r^{ij} \mathbf{F}_j^{(l-1)} \mathbf{\Theta}_r^{(l-1)} + c_i^i \mathbf{F}_i^{(l-1)} \right), \quad (13.6)$$

where $\mathbf{F}_i^{(l)}$ is the hidden representation of node v_i after the l -th layer, $r \in \mathcal{R}$ is a relation type and $\mathcal{N}_r(v_i)$ denotes the set of neighbors of node v_i under the relation of r . The matrix $\mathbf{\Theta}_r^{(l-1)}$ is a transform matrix specific to the relation

type r . c_r^{ij} and c_r^i are normalization constants defined as follows:

$$c_r^{ij} = \frac{1}{\sqrt{|\mathcal{N}_r(v_i)||\mathcal{N}_r(v_j)|}},$$

$$c_r^i = \frac{1}{|\mathcal{N}_r(v_i)|}.$$

The input of the first layer is the node features $\mathbf{F}_i^{(0)} = \mathbf{x}_i$. The final node representations are the output of the L -th layer, i.e., $\mathbf{z}_i = \mathbf{F}_i^{(L)}$, where \mathbf{z}_i denotes the final representation of node v_i . With the learned node representations, given a pair of drugs v_i, v_j , the probability of a relational edge with relation r existing between them is modeled as:

$$p(v_i, r, v_j) = \sigma(\mathbf{z}_i^T \mathbf{D}_r \mathbf{R} \mathbf{D}_r \mathbf{z}_j), \quad (13.7)$$

where $\sigma()$ is the sigmoid function, \mathbf{R} is a learnable matrix shared by all relations and \mathbf{D}_r is a learnable diagonal matrix specific to relation r . The reason to use a shared matrix \mathbf{R} is that many relations (side effects) between drugs are rarely observed, and learning specific matrices for them may cause overfitting. Introducing the shared parameter matrix \mathbf{R} largely reduces the number of parameters of the model; hence it can help prevent overfitting. During the training stage, the parameters in both the graph filters in Eq. (13.6) and the prediction model in Eq. (13.7) are optimized by maximizing the probability in Eq. (13.7) for those observed side effects between drugs. Note that in (Zitnik et al., 2018), other types of relations, i.e., protein-protein interactions and drug-protein interactions, are also reconstructed during the training with their probabilities formulated similar to Eq. (13.7).

13.5 Disease Prediction

Increasing volume of medical data, which usually contains imaging, genetic and behavioral data, is collected and shared to facilitate the understanding of disease mechanisms. The task of disease prediction is to tell whether a subject is diseased or not given its corresponding medical image and non-image data. The medical images are often the MRI images of the subjects, and the non-image data usually includes phenotypic data such as age, gender, and acquisition site. These two types of information are complementary to each other. Hence, facilitating both information effectively is necessary to enhance the performance of disease prediction. The image data directly provides the features corresponding to some diseases of the subject, and the phenotypic information provides some association between the subjects. For example, subjects with

similar ages tend to have more similar outcomes than those with very different ages when all other conditions are the same. Graphs provide an intuitive way of modeling these two types of information, where we treat subjects as nodes with their image as node features and the associations between them as edges. With the built graph, the disease prediction task can be treated as a binary semi-supervised node classification task. It can be tackled by the graph neural network models, as introduced in Section 5.5.1. Next, we briefly introduce the process of building the graph using the ABIDE database (Di Martino et al., 2014) as an illustrative example (Parisot et al., 2018).

The ABIDE database contains neuroimaging (functional MRI) and phenotypic data of subjects from different international acquisition sites. With this database, we aim to predict whether a subject is healthy or suffering from the autism spectrum disorder (ASD). Each subject is modeled as a node v_i in the graph \mathcal{G} , and \mathbf{x}_i denotes the features extracted from its corresponding fMRI image. To build the edges between the nodes (i.e. the adjacency matrix for the graph), we consider both the image data and the non-image phenotypic measures $\mathcal{M} = \{M_h\}_{h=1}^H$ as:

$$\mathbf{A}_{i,j} = \text{sim}(\mathbf{x}_i, \mathbf{x}_j) \sum_{h=1}^H \gamma_h(M_h(v_i), M_h(v_j)),$$

where \mathbf{A} denotes the adjacency matrix, $\text{sim}(\mathbf{x}_i, \mathbf{x}_j)$ computes the similarity between the features of two nodes v_i and v_j , $M_h(v_i)$ is the h -th phenotypic measure of node v_i and $\gamma_h()$ calculates their similarity. The similarity function $\text{sim}(\mathbf{x}_i, \mathbf{x}_j)$ can be modeled with Gaussian kernels, where nodes with smaller distance have a higher similarity score. Three phenotypic measures, acquisition site, gender and age, are utilized, i.e. we have $H = 3$ for the ABIDE database. The acquisition site is considered since the database is acquired from very different sites with diverse acquisition protocol, which results in less comparable images across different acquisition sites. Gender and age are considered since gender-related and age-related group differences have been observed (Werling and Geschwind, 2013; Kana et al., 2014). For gender and acquisition site, the function $\gamma_h()$ is defined as the Kronecker delta function, which takes value 1 if and only if the two inputs are the same (i.e. they are from the same acquisition site or they have the same gender), otherwise 0. For age, the function $\gamma_h()$ is defined as:

$$\gamma_h(M_h(v_i), M_h(v_j)) = \begin{cases} 1 & \text{if } |M_h(v_i) - M_h(v_j)| < \theta \\ 0 & \text{otherwise} \end{cases},$$

where θ is a predefined threshold. This means that subjects with age difference smaller than θ are considered to be similar with each other.

13.6 Conclusion

In this chapter, we introduced various representative applications of graph neural network models in biochemistry and healthcare. We discuss the applications of graph neural network models in molecule representation learning, drug-target binding affinity prediction, and protein interface prediction. These tasks can facilitate the development and discovery of novel drugs. Next, we introduced an autoencoder based on graph filters to integrate multi-view drug similarities. We also described how graph neural network models can be used for polypharmacy side effect prediction. Besides, we discussed how graph neural network models can be leveraged for disease prediction.

13.7 Further Reading

In addition to the applications we have detailed in this chapter, graph neural networks have been adopted or served as building blocks to benefit many other biochemistry tasks. They are employed as building blocks in models designed for medication recommendation (Shang et al., 2019b,c). In (You et al., 2018a), the graph neural network models have been leveraged as policy networks for molecule graph generation with reinforcement learning. Besides, graph neural network models have also been employed for computational phenotyping (Zhu et al., 2019b; Choi et al., 2020) and disease association prediction (Xuan et al., 2019; Li et al., 2019a).

PART FOUR

ADVANCES

14

Advanced Topics in Graph Neural Networks

14.1 Introduction

In Part TWO, we have discussed the most established methods of deep learning on graphs. On the one hand, with the increasingly deep understandings, numerous limitations have been identified for existing GNNs. Some of these limitations inherit from traditional DNNs. For example, as DNNs, GNNs are often treated as black-boxes and lack human-intelligible explanations; and they might present discrimination behaviors to protected groups that can result in unprecedented ethical, moral, and even legal consequences for human society. Others are unique to GNNs. For instance, increasing the number of layers of GNNs often leads to significant performance drop, and there are limitations on the expressive power of existing GNNs in distinguishing graph structures. On the other hand, recently, more successful experiences from traditional DNNs have been adapted to advance GNNs. For example, strategies have been designed to explore unlabeled data for GNNs, and there are attempts to extend GNNs from Euclidean space to hyperbolic space. We package these recent efforts into this chapter about advanced topics in GNNs with two goals. First, we aim to bring our readers near the frontier of current research on GNNs. Second, these topics can serve as promising future research directions. For the aforementioned advanced topics, some are relatively well developed, including deeper graph neural networks, exploring unlabeled data via self-supervised learning for GNNs, and the expressiveness of GNNs. We will detail them in the following sections. In contrast, others are just initialized, and we will provide corresponding references as further reading.

14.2 Deeper Graph Neural Networks

It is observed that increasing the number of graph filtering layers (such as GCN-Filter, GAT-Filter; see Section 5.3.2 for more graph filtering operations) to a large number often results in a significant drop in node classification performance. The performance drop is mainly caused by *oversmoothing*. It describes the phenomenon that the node features become similar and less distinguishable as the number of graph filtering layers increases (Li et al., 2018b). Next, we discuss the “*oversmoothing*” issue based on the GCN-Filter. Intuitively, from a spatial perspective, the GCN-Filter is to update a node’s representation by “averaging” its neighbors’ representations. This process naturally renders representations for neighboring nodes to be similar. Thus, deeply stacking graph filtering operations tends to make all the nodes (assume that the graph is connected) have similar representations. In (Li et al., 2018b), the *oversmoothing* phenomenon is studied asymptotically as the number of graph filtering layers goes to infinity. Specifically, when the number of filtering layers goes to infinity, the nodes’ representations converge to the same regardless of their input features. For the ease of analysis, the non-linear activation layers between the graph filtering layers are ignored in (Li et al., 2018b). Without the non-linear activation layers, repeatedly applying L GCN-Filters to the input features \mathbf{F} can be expressed as:

$$\begin{aligned} & \tilde{\mathbf{D}}^{-\frac{1}{2}} \tilde{\mathbf{A}} \tilde{\mathbf{D}}^{-\frac{1}{2}} \left(\dots \left(\tilde{\mathbf{D}}^{-\frac{1}{2}} \tilde{\mathbf{A}} \tilde{\mathbf{D}}^{-\frac{1}{2}} \left(\tilde{\mathbf{D}}^{-\frac{1}{2}} \tilde{\mathbf{A}} \tilde{\mathbf{D}}^{-\frac{1}{2}} \mathbf{F} \Theta^{(0)} \right) \Theta^{(1)} \right) \dots \right) \Theta^{(L-1)}, \\ & = \left(\tilde{\mathbf{D}}^{-\frac{1}{2}} \tilde{\mathbf{A}} \tilde{\mathbf{D}}^{-\frac{1}{2}} \right)^L \mathbf{F} \Theta, \end{aligned} \quad (14.1)$$

where Θ denotes the multiplication of $\Theta^{(0)}, \dots, \Theta^{(L-1)}$, $\tilde{\mathbf{A}} = \mathbf{A} + \mathbf{I}$ as introduced in the GCN-Filter in Eq. (5.21) and $\tilde{\mathbf{D}}$ is the corresponding degree matrix. The filtering process in Eq. (14.1) can be viewed as applying the operation $\left(\tilde{\mathbf{D}}^{-\frac{1}{2}} \tilde{\mathbf{A}} \tilde{\mathbf{D}}^{-\frac{1}{2}} \right)^L$ to each column of $\mathbf{F} \Theta$.

The following theorem (Li et al., 2018b) demonstrates the *oversmoothing* phenomenon on single channel graph signals:

Theorem 14.1 *Let \mathcal{G} denote a connected non-bipartite graph with \mathbf{A} as its adjacency matrix. Then, for any input feature $\mathbf{f} \in \mathbb{R}^N$, we have*

$$\lim_{L \rightarrow \infty} \left(\tilde{\mathbf{D}}^{-\frac{1}{2}} \tilde{\mathbf{A}} \tilde{\mathbf{D}}^{-\frac{1}{2}} \right)^L \mathbf{f} = \theta_1 \cdot \mathbf{u}_1, \quad (14.2)$$

where $\tilde{\mathbf{A}} = \mathbf{A} + \mathbf{I}$ and $\tilde{\mathbf{D}}$ denotes its corresponding degree matrix. Here $\tilde{\mathbf{A}}$ can be regarded as the adjacency matrix of a modified version of graph \mathcal{G} with self-loops. The vector \mathbf{u}_1 is the eigenvector of $\tilde{\mathbf{D}}^{-\frac{1}{2}} \tilde{\mathbf{A}} \tilde{\mathbf{D}}^{-\frac{1}{2}}$ associated with its

largest eigenvalue and $\theta_1 = \mathbf{u}_1^\top \mathbf{f}$. In detail, $\mathbf{u}_1 = \tilde{\mathbf{D}}^{-\frac{1}{2}} \mathbf{1}$, which only contains the information of the node degree.

Proof Let $\tilde{\mathbf{L}}_{nor} = \mathbf{I} - \tilde{\mathbf{D}}^{-\frac{1}{2}} \tilde{\mathbf{A}} \tilde{\mathbf{D}}^{-\frac{1}{2}}$ denote the normalized Laplacian matrix corresponding to $\tilde{\mathbf{A}}$. According to Lemma 1.7 in (Chung and Graham, 1997), $\tilde{\mathbf{L}}_{nor}$ has a complete set of eigenvalues $0 = \lambda_1 < \lambda_2 \dots, \lambda_N < 2$ with their corresponding eigenvectors $\mathbf{u}_1, \dots, \mathbf{u}_N$. Specifically, in the matrix form, the eigen-decomposition of $\tilde{\mathbf{L}}_{nor}$ can be represented as $\tilde{\mathbf{L}}_{nor} = \mathbf{U} \mathbf{\Lambda} \mathbf{U}^\top$, where $\mathbf{U} = [\mathbf{u}_1, \dots, \mathbf{u}_N]$ is the matrix that consists of all eigenvectors and $\mathbf{\Lambda} = \text{diag}([\lambda_1, \dots, \lambda_N])$ is the diagonal eigenvalue matrix. The eigenvalues and eigenvectors of $\tilde{\mathbf{D}}^{-\frac{1}{2}} \tilde{\mathbf{A}} \tilde{\mathbf{D}}^{-\frac{1}{2}}$ can be related to those of $\tilde{\mathbf{L}}$ as:

$$\tilde{\mathbf{D}}^{-\frac{1}{2}} \tilde{\mathbf{A}} \tilde{\mathbf{D}}^{-\frac{1}{2}} = \mathbf{I} - \tilde{\mathbf{L}}_{nor} = \mathbf{U} \mathbf{U}^\top - \mathbf{U} \mathbf{\Lambda} \mathbf{U}^\top = \mathbf{U} (\mathbf{I} - \mathbf{\Lambda}) \mathbf{U}^\top.$$

Hence, $1 = 1 - \lambda_1 > 1 - \lambda_2 \dots, > 1 - \lambda_N > -1$ are the eigenvalues of $\tilde{\mathbf{D}}^{-\frac{1}{2}} \tilde{\mathbf{A}} \tilde{\mathbf{D}}^{-\frac{1}{2}}$ with $\mathbf{u}_1, \dots, \mathbf{u}_N$ as its corresponding eigenvectors. Then, we have

$$\left(\tilde{\mathbf{D}}^{-\frac{1}{2}} \tilde{\mathbf{A}} \tilde{\mathbf{D}}^{-\frac{1}{2}} \right)^L = \left(\mathbf{U} (\mathbf{I} - \mathbf{\Lambda}) \mathbf{U}^\top \right)^L = \mathbf{U} (\mathbf{I} - \mathbf{\Lambda})^L \mathbf{U}^\top.$$

As the eigenvalues of $\tilde{\mathbf{A}}$ are in the range of $[0, 1)$, the limit in Eq. (14.2) can be expressed as:

$$\begin{aligned} \lim_{k \rightarrow \infty} \left(\tilde{\mathbf{D}}^{-\frac{1}{2}} \tilde{\mathbf{A}} \tilde{\mathbf{D}}^{-\frac{1}{2}} \right)^L \mathbf{f} &= \lim_{k \rightarrow \infty} \mathbf{U} (\mathbf{I} - \mathbf{\Lambda})^L \mathbf{U}^\top \mathbf{f} \\ &= \mathbf{U} \text{diag}([1, 0, \dots, 0]) \mathbf{U}^\top \mathbf{f} \\ &= \mathbf{u}_1 \cdot (\mathbf{u}_1^\top \mathbf{f}) \\ &= \theta_1 \cdot \mathbf{u}_1, \end{aligned}$$

which completes the proof. \square

Theorem 14.1 shows that repeatedly applying the GCN-Filters to a graph signal \mathbf{f} results in $\theta_1 \cdot \mathbf{u}_1$, which captures information no more than the node degrees. For the multi-channel case as shown in Eq. (14.1), each column of the matrix $\mathbf{F}\Theta$ is mapped to $\theta_1 \cdot \mathbf{u}_1$ with different θ_1 . Hence, different columns contain the same information with different scales. Furthermore, the degree information contained in \mathbf{u}_1 is likely not be useful for most node classification tasks, which also explains why the node classification performance decreases as the number of graph filtering layers increases. Similar observations for the case where the non-linear activation (limited to the ReLU activation function) is included are made in (Oono and Suzuki, 2020). Specifically, it is shown in (Oono and Suzuki, 2020) that the ReLU activation function accelerates the process of *oversmoothing*. The goal of the GCN-Filter is to update node representations with the information of neighboring nodes. Stacking k

GCN-Filters allows each node to access information from its k -hop neighborhood. To achieve good performance for node classification, it is necessary to aggregate the information from the local neighborhood for each node. However, as shown in above, stacking too many graph filtering layers leads to the *oversmoothing* issue. Various remedies have been proposed to alleviate the oversmoothing issue (Xu et al., 2018a; Rong et al., 2020; Zhao and Akoglu, 2019).

14.2.1 Jumping Knowledge

It is argued in (Xu et al., 2018a) that different nodes require neighborhoods with different depth and thus different numbers of graph filtering layers are required for different nodes. Hence, a strategy named *Jumping Knowledge* is proposed in (Xu et al., 2018a), which adaptively combines the hidden representations for each node from different layers as the final representations. Specifically, let $\mathbf{F}_i^{(1)}, \dots, \mathbf{F}_i^{(L)}$ be the hidden representations for node v_i after the 1, \dots , L -th layer, respectively. These representations are combined to generate the final representation for node v_i as follows:

$$\mathbf{F}_i^o = \text{JK}(\mathbf{F}_i^{(0)}, \mathbf{F}_i^{(1)}, \dots, \mathbf{F}_i^{(L)}),$$

where $\text{JK}()$ is a function which is adaptive for each node. In particular, it can be implemented as the max-pooling operation or an attention based LSTM.

14.2.2 DropEdge

Dropedge (Rong et al., 2019) is introduced to alleviate the *oversmoothing* issue by randomly dropping some edges in the graph during each training epoch. Specifically, before the training of each epoch, a fraction of edges \mathcal{E}_p is uniformly sampled from \mathcal{E} with a sampling rate p . These sampled edges are removed from the edge set, and the remaining edges are denoted as $\mathcal{E}_r = \mathcal{E}/\mathcal{E}_p$. The graph $\mathcal{G}' = \{\mathcal{V}, \mathcal{E}_r\}$ is then used for training in this epoch.

14.2.3 PairNorm

As discussed before, we desire some smoothness of the node representations to ensure good classification performance while preventing them from being too similar. An intuitive idea is to ensure that the representations of disconnected nodes are relatively distant. In (Zhao and Akoglu, 2019), PairNorm is proposed that introduces a regularization term to force representations of nodes that are not connected to be different.

14.3 Exploring Unlabeled Data via Self-supervised Learning

To train good deep learning models, it usually requires a huge amount of labeled data. For a specific task, it is usually hard and expensive to collect/annotate massive labeled data. However, unlabeled data is typically rich and easy to obtain. For instance, if we are building a sentiment analysis model, the annotated data might be limited, while unlabeled texts are widely available. Thus, it is appealing to take advantage of unlabeled data. In fact, unlabeled data has been used to advance many areas, such as computer vision and natural language processing. In image recognition, deep convolutional neural networks pre-trained on ImageNet such as Inception (Szegedy et al., 2016) and VGG (Simonyan and Zisserman, 2014) have been widely adopted. Note that images from ImageNet are originally labeled; however, they are considered as unlabeled data for a given specific image recognition task, which could have very different labels from these in the ImageNet dataset. In natural language processing, pre-trained language models such as GPT-2 (Radford et al., 2019) and BERT (Devlin et al., 2018) have been adopted to achieve the state of the art performance for various tasks such as question answering and natural language generation. Therefore, it is promising and has the great potential to explore unlabeled data to enhance deep learning on graphs. This chapter discusses how graph neural networks can use unlabeled data for node classification and graph classification/regression tasks. For node classification, unlabeled data has been incorporated by graph neural networks via the simple information aggregation process. This process could be insufficient to make use of unlabeled data fully. Hence, we discuss strategies to leverage unlabeled data more thoroughly. In graph classification/regression tasks, labeled graphs could be limited, but many unlabeled graphs are available. For example, when performing classification/regression tasks on molecules, labeling molecules is expensive, while unlabeled molecules can be easily collected. Therefore, we present approaches to leverage unlabeled graphs for graph-focused tasks.

14.3.1 Node-focused Tasks

The success of deep learning relies on massive labeled data. Self-supervised learning (SSL) has been developed to alleviate this limitation. It often first designs a domain-specific pretext task and then learns better representations with the pretext task to include unlabeled data. As aforementioned, GNNs simply aggregate features of unlabeled data that cannot thoroughly take advantage of the abundant information. Thus, to fully explore unlabeled data, SSL has been harnessed for providing additional supervision for GNNs. The node-focused

self-supervised tasks usually generate additional supervised signals from the graph structure and/or node attributes. Such generated self-supervised information can serve as the supervision of auxiliary tasks to improve the performance of GNNs on the node classification task. There are majorly two ways to utilize these generated self-supervised signals (Jin et al., 2020c): 1) two-stage training, where the self-supervised task is utilized to pre-train the graph neural network model, and then the graph neural network model is fine-tuned for the node classification task; 2) joint training, where the self-supervised task and the main task are optimized together. Specifically, the objective of joint training can be formulated as follows:

$$\mathcal{L} = \mathcal{L}_{label} + \eta \cdot \mathcal{L}_{self},$$

where \mathcal{L}_{label} denotes the loss of the main task, i.e., node classification task and \mathcal{L}_{self} is the loss of the self-supervised task. Next, we briefly introduce some of the self-supervised tasks. In detail, we categorize these self-supervised tasks by the information they leverage to construct the self-supervised signals: 1) constructing self-supervised signals with graph structure information; 2) constructing self-supervised signals with node attribute information; and 3) constructing self-supervised signals with both graph structure and node attribute information.

Graph Structure Information

In this subsection, we introduce self-supervised tasks based on graph structure information.

- **Node Property** (Jin et al., 2020c). In this task, we aim to predict the node property using the learned node representations. These node properties can be node degree, node centrality, and local clustering coefficient.
- **Centrality Ranking** (Hu et al., 2019). In this task, we aim to preserve the centrality ranking of the nodes. Instead of directly predict centrality as that in **Node Property**, the task aims to predict pair-wise ranking given any pair of nodes.
- **Edge Mask** (Jin et al., 2020c; Hu et al., 2020, 2019). In this task, we randomly mask (or remove) some edges from the graph and try to predict their existence using the node representations learned by graph neural networks.
- **Pairwise Distance** (Peng et al., 2020; Jin et al., 2020c). In this task, we aim to utilize the node representations to predict the distance between pairs of nodes in the graph. Specifically, the distance between two nodes is measured by the length of the shortest path between them.

- **Distance2Clusters** (Jin et al., 2020c). Instead of predicting the distance between node pairs, in this task, we aim to predict the distance between a node to the clusters in the graph, which can help learn the global position information of these nodes. Clustering methods based on graph structure information such as METIS graph partitioning algorithm (Karypis and Kumar, 1998) are first utilized to generate a total of K clusters. Then, for each cluster, the node with the largest degree in this cluster is chosen as its center. The task of Distance2Cluster is to predict the distances between a node to the centers of these K clusters. Again, the distance is measured by the length of the shortest path between nodes.

Node Attribute Information

In this subsection, we introduce self-supervised tasks based on node attribute information.

- **Attribute Mask** (Jin et al., 2020c; You et al., 2020; Hu et al., 2020). In this task, we randomly mask (or remove) the associated attribute information of some nodes in the graph and aim to utilize the node representations learned from the graph neural network models to predict these node attributes.
- **PairwiseAttrSim** (Jin et al., 2020c). This task is similar to Pair-wise Distance in the sense that we also aim to predict pair-wise information between nodes. Specifically, we aim to predict the similarity between node attributes, where the similarity can be measured by cosine similarity or Euclidean distance.

Graph Structure and Node Attribute Information

In this subsection, we introduce self-supervised tasks based on both graph structure and node attribute information.

- **Pseudo Label** (Sun et al., 2019c; You et al., 2020). In this task, pseudo labels are generated for unlabeled nodes using the graph neural network model or other models. Then they are utilized as supervised signals to re-train the model together with the labeled nodes. In (You et al., 2020), clusters are generated using the learned node representations from the graph neural network model, and the clusters are used as the pseudo labels. In (Sun et al., 2019c), these clusters are aligned with the real labels and then employed as the pseudo labels.
- **Distance2Labeled** (Jin et al., 2020c). This task is similar to the task of Distance2Cluster. Instead of predicting distance between nodes and pre-calculated clusters, we aim to predict the distance between unlabeled nodes to the labeled nodes.

- **ContextLabel** (Jin et al., 2020c). The ContextLabel task is to predict the label distribution of the context for the nodes in the graph. The context of a given node is defined as all its k -hop neighbors. The label distribution of the nodes in the context of a given node can then be formulated as a vector. Its dimension is the number of classes where each element indicates the frequency of the corresponding label in the context. Nevertheless, the label information of the unlabeled nodes is unknown. Hence the distribution can not be accurately measured. In (Jin et al., 2020c), methods such as Label propagation (LP) (Zhu et al., 2003) and Iterative Classification Algorithm (ICA) (Neville and Jensen, n.d.) are adopted to predict the pseudo labels, which are then used to estimate the label distribution.
- **CorrectedLabel** (Jin et al., 2020c). This task is to enhance the ContextLabel task by iteratively refining the pseudo labels. Specifically, there are two phases in this task: the training phase and the label correction phase. Given the pseudo labels, the training phase is the same as the task of ContextLabel. The predicted pseudo labels in the training phase are then refined in the label correction phase using the noisy label refining algorithm proposed in (Han et al., 2019). These refined (corrected) pseudo labels are adopted to extract the context label distribution in the training phase.

14.3.2 Graph-focused Tasks

In the graph-focused tasks, we denote the set of labeled graphs as $\mathcal{D}_l = \{(\mathcal{G}_i, y_i)\}$, where y_i is the associated label of the graph \mathcal{G}_i . The set of unlabeled graphs is denoted as $\mathcal{D}_u = \{(\mathcal{G}_j)\}$. Typically, the number of the unlabeled graphs is much larger than that of labeled graphs, i.e., $|\mathcal{D}_u| \gg |\mathcal{D}_l|$. Exploring unlabeled data aims to extract knowledge from \mathcal{D}_u to help train models on \mathcal{D}_l . To take advantage of unlabeled data, self-supervision signals are extracted. As the node-focused case, there are mainly two ways to leverage knowledge from \mathcal{D}_u . One is via two-stage training, where GNNs are pre-trained on the unlabeled data \mathcal{D}_u with the self-supervised objective and then fine-tuned on the labeled data \mathcal{D}_l . The other is through joint training, where the self-supervised objective is included as a regularization term to be optimized with the supervised loss. In this section, we introduce graph level self-supervised tasks.

- **Context Prediction** (Hu et al., 2019). In context prediction, the pre-training task is to predict whether a given pair of K -hop neighborhood and context graph belongs to the same node. Specifically, for every node v in a graph \mathcal{G} , its K -hop neighborhood consists of all nodes and edges that are at most K -hops away from node v in \mathcal{G} , which can be denoted as $\mathcal{N}_{\mathcal{G}}^K(v)$. Meanwhile,

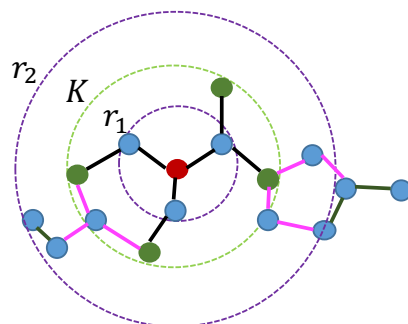

Figure 14.1 Context Prediction

the *context graph* of a node $v \in \mathcal{G}$ is defined by two hyper-parameters r_1, r_2 , and it is a subgraph that contains nodes and edges between r_1 and r_2 hops away from the node v in the graph \mathcal{G} . In detail, the context graph of node v in a graph \mathcal{G} is a ring of width $r_2 - r_1$ as shown in Figure 14.1, which can be denoted as $C_{v,\mathcal{G}}$. Note that r_1 is required to be smaller than K to ensure that there are some nodes shared between the *neighborhood* and the *context graph* of node v . The task of context prediction is then modeled as a binary classification. It is to determine whether a particular neighborhood $\mathcal{N}_{\mathcal{G}}^K(v)$ and a particular *context graph* $C_{v,\mathcal{G}}$ belong to the same node. A similar task is proposed in (Sun et al., 2019b) where, given a node and a graph, the goal is to predict whether the node belongs to the given graph.

- **Attribute Masking** (Hu et al., 2019). In attribute masking, some node/edge attributes (e.g., atom types in molecular graphs) in a given graph from \mathcal{D}_u is randomly masked. Then graph neural network models are trained to predict these masked node/edge attributes. Note that the attribute masking strategy can only be applied to graphs with node/edge attributes.
- **Graph Property Prediction** (Hu et al., 2019). While there might be no labels for graphs in \mathcal{D}_u for the specific task we want to perform on \mathcal{D}_l , there could be other graph attributes available for them. These graph attributes can serve as the supervised signal to pre-train the graph neural network model.

14.4 Expressiveness of Graph Neural Networks

Increasing efforts have been made to analyze the expressiveness of graph neural network models. They aim to analyze the capability of graph neural network models to distinguish graph structures from the graph-level perspective.

Hence, for the ease of discussion, we quickly recap the graph neural network models for graph-focused tasks. We write a general aggregation based spatial graph filter of the l -th layer of graph neural network model as:

$$\begin{aligned}\mathbf{a}_i^{(l)} &= \text{AGG}\left(\{\mathbf{F}_j^{(l-1)} | v_j \in \mathcal{N}(v_i)\}\right), \\ \mathbf{F}_i^{(l)} &= \text{COM}\left(\mathbf{F}_i^{(l-1)}, \mathbf{a}_i^{(l)}\right),\end{aligned}$$

where $\mathbf{a}_i^{(l)}$ represents the information aggregated from the neighbors of node v_i with the function $\text{AGG}()$ and $\mathbf{F}_i^{(l)}$ is the hidden representation of node v_i after the l -th graph filtering layer. The function $\text{COM}()$ combines the hidden representation of node v_i from the $(l-1)$ -th layer together with the aggregated information to generate the hidden representations in the l -th layer. For graph-focused tasks, a pooling operation is usually operated on the representations $\{\mathbf{F}_i^{(L)} | v_i \in \mathcal{V}\}$ to generate the graph representation, where L is the number of graph filtering layers. Note that, in this chapter, for convenience, we only consider flat pooling operations and the process of pooling is described as:

$$\mathbf{F}_{\mathcal{G}} = \text{POOL}\left(\{\mathbf{F}_i^{(L)} | v_i \in \mathcal{V}\}\right),$$

where $\mathbf{F}_{\mathcal{G}}$ denotes the graph representation. There are different choices and designs for the $\text{AGG}()$, $\text{COM}()$, and $\text{POOL}()$ functions, which results in graph neural network models with different expressiveness. It is shown in (Xu et al., 2019d) that no matter what kinds of functions are adopted, the graph neural network models are at most as powerful as Weisfeiler-Lehman (WL) graph isomorphism test (Weisfeiler and Leman, n.d.) in distinguishing graph structures. The WL test is a powerful test, which can distinguish a broad class of graph structures. Conditions are further established under which the graph neural network models can be as powerful as the WL test in distinguishing graph structures. Next, we first briefly introduce the WL test and how graph neural network models are related. We then present some key results on the expressiveness of graph neural network models.

14.4.1 Weisfeiler-Lehman Test

Two graphs are considered to be topologically identical (or isomorphic) if there is a mapping between the node sets of the graphs such that the adjacency relations are the same. For example, two isomorphic graphs are shown in Figure 14.2, where the color and number indicate the mapping relations between the two sets of nodes. The graph isomorphism task aims to tell whether two given graphs \mathcal{G}_1 and \mathcal{G}_2 are topologically identical. It is computationally expensive to test graph isomorphism, and no polynomial-time algorithm has been

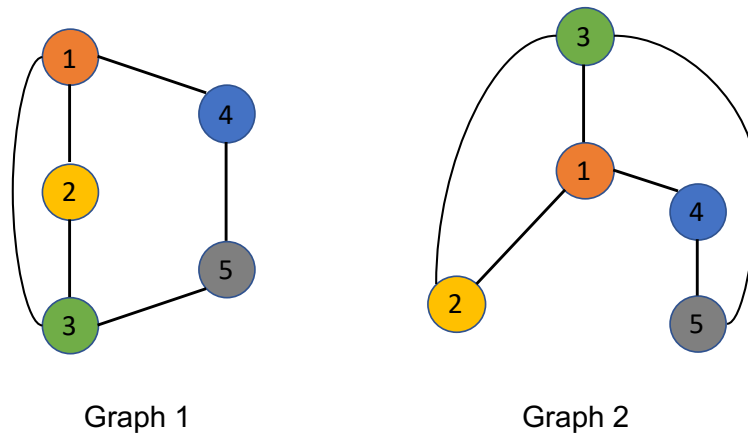

Figure 14.2 Two isomorphic graphs

found yet (Garey and Johnson, n.d.; Babai, 2016). The Weisfeiler-Lehman test is an efficient and effective approach for the graph isomorphism task. It can distinguish a broad class of graphs while failing to distinguish some corner cases (Cai et al., 1992).

For convenience, we assume that each node in the two graphs is associated with labels (attributes). For example, in Figure 14.2, the numbers can be treated as the labels. In practice, the same labels could be associated with different nodes in the graph. A single iteration of the WL test can be described as:

- For each node v_i , we aggregate its neighbors' labels (including itself) into a multi-set $\mathcal{NL}(v_i)$, i.e., a set with repeated elements.
- For each node v_i , we hash the multi-set $\mathcal{NL}(v_i)$ into a unique new label, which is now associated with node v_i as its new label. Note that any nodes with the same multi-set of labels are hashed to the same new label.

The above iteration is repeatedly applied until the sets of labels of two graphs differ from each other. If the sets of labels differ, then the two graphs are non-isomorphic, and the algorithm is terminated. After N (or the number of nodes in the graph) iterations, if the sets of labels of the two graphs are still the same, the two graphs are considered to be isomorphic, or the WL test fails to distinguish them (see (Cai et al., 1992) for the corner cases where the WL test fails). Note that the graph neural network models can be regarded as a generalized WL test. Specifically, the AGG() function in the GNNs corresponds to the ag-

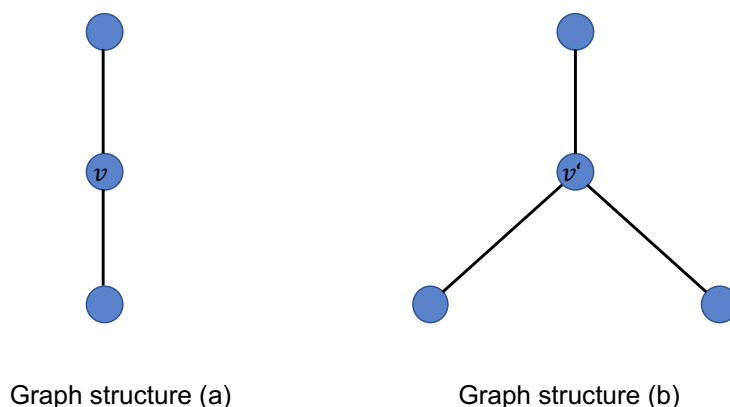

Figure 14.3 Graph structures that mean and max functions fail to distinguish

gregation step in the WL test, and the $\text{COM}()$ function corresponds to the hash function in the WL test.

14.4.2 Expressiveness

The expressiveness of the graph neural network models can be related to the graph isomorphism task. Ideally, a graph neural network model with sufficient expressiveness can distinguish graphs with different structures by mapping them into different embeddings. The following lemma shows that the graph neural network models are at most as powerful as the WL test in distinguishing non-isomorphic graphs.

Lemma 14.2 (Xu et al., 2019d) *Given any two non-isomorphic graphs \mathcal{G}_1 and \mathcal{G}_2 , if a graph neural network model maps these two graphs into different embeddings, the WL test also decides that these two graphs are non-isomorphic.*

The power of the WL test is largely attributed to its injective aggregation operation, i.e., the hash function maps nodes with different neighborhoods to different labels. However, many popular aggregation functions in graph neural network models are not injective. Next, we briefly discuss some $\text{AGG}()$ functions and provide examples of graph structures where these $\text{AGG}()$ functions fail to distinguish. Both the mean function and max function introduced in (Hamilton et al., 2017a) are not injective. As shown in Figure 14.3, assuming that all nodes have the same label (or the same feature), the local structures

of nodes v and v' are distinct as they have different numbers of neighbors. However, if mean or max is adopted as the AGG() function, the same representation is obtained as the aggregation result for nodes v and v' . Hence, these two substructures shown in Figure 14.3 cannot be distinguished if mean or max is adopted as the AGG() function. To improve the expressiveness of the GNN models, it is important to design the functions carefully, including AGG(), COM(), and POOL() to be injective. Specifically, the graph neural network models are as powerful as WL test if all these functions are injective as stated in the following theorem:

Theorem 14.3 (Xu et al., 2019d) *A graph neural network model with sufficient graph filtering layers can map two graphs that are tested as non-isomorphic by the WL test to different embeddings, if all AGG(), COM() and POOL() functions in the graph neural network model are injective.*

Theorem 14.3 provides guidance on designing graph neural network models with high expressiveness. While the graph neural network models are at most as powerful as the WL test in distinguishing graph structures, they have their advantages over the WL test. The GNNs models can map graphs into low-dimensional embeddings, which capture the similarity between them. However, the WL test is not able to compare the similarity between graphs except for telling whether they are isomorphic or not. Hence, GNNs are suitable for tasks like graph classification, where graphs can have different sizes, and non-isomorphic graphs with similar structures could belong to the same class.

14.5 Conclusion

In this chapter, we discussed advanced topics in graph neural networks. We describe the oversmoothing issue in graph neural networks and discuss some remedies to mitigate this issue. We introduce various self-supervised learning tasks on graph-structured data for both node- and graph-focused tasks. We demonstrate that the graph neural network models are at most as powerful as the WL test in distinguishing graph structures and provide some guidance in developing graph neural networks with high expressiveness.

14.6 Further Reading

As aforementioned, there are more new directions on graph neural networks that are just initialized. In (Ying et al., 2019; Yuan et al., 2020), explainable

graph neural network models have been developed. Specifically, In (Ying et al., 2019), sample-level explanations are generated for graph neural networks, i.e., generating explanations for each sample. While in (Yuan et al., 2020), model-level explanations have been studied for graph neural networks, i.e., understanding how the entire graph neural network model works. In (Tang et al., 2020), the fairness issues of GNNs have been investigated. It is observed that the node classification performance based on GNNs varies in terms of the node degrees. In particular, nodes with low-degrees tend to have a higher error rate than those with high degrees. In (Chami et al., 2019; Liu et al., 2019a), graph neural networks have been extended to hyperbolic space to facilitate both the expressiveness of GNNs and the hyperbolic geometry.

15

Advanced Applications in Graph Neural Networks

15.1 Introduction

In PART THREE, we have introduced representative applications of graph neural networks, including natural language processing, computer vision, data mining, and biochemistry and healthcare. Graph neural networks have been employed to facilitate more advanced applications as graphs are natural representations of data produced by many real-world applications and systems. Numerous combinatorial optimization problems on graphs such as minimum vertex cover and the traveling salesman problem are NP-Hard. Graph neural networks have been used to learn the heuristics for these NP-hard problems. Graphs can denote source code in programs from many perspectives, such as data and control flow. Thus, graph neural networks can be naturally leveraged to learn representations for source code to automate various tasks such as variable misuse detection and software vulnerability detection. For dynamical systems in Physics, the objects and their relations can often be denoted as graphs. Graph neural networks have been adopted to infer future states of dynamic systems. This chapter discusses these advanced and sophisticated applications and then introduces how graph neural networks can be applied.

15.2 Combinatorial Optimization on Graphs

Many combinatorial optimization problems on graphs such as minimum vertex cover (MVC) and travelling salesman problem (TSP) are NP-Hard. In other words, no polynomial-time solutions are available for them (under the condition $P \neq NP$). These problems are hence usually tackled by approximation algorithms or heuristics. Designing good heuristics is usually a challenging and tedious process, which requires significant problem-specific knowledge

and trial-and-error. Hence, it is desired to learn heuristics automatically. Graph neural networks have been utilized to learn these heuristics from given samples and then try to find solutions for unseen tasks. Next, we first describe some combinatorial optimization problems on graphs and then briefly introduce how graph neural networks can be leveraged to facilitate these tasks.

- **Minimum Vertex Cover (MVC).** Given a graph $\mathcal{G} = \{\mathcal{V}, \mathcal{E}\}$, a vertex cover $\mathcal{S} \subset \mathcal{V}$ is a subset of vertices that includes at least one endpoint for every edge in \mathcal{E} . The problem of minimum vertex cover (MVC) is to find a vertex cover that has the smallest amount of nodes.
- **Maximum Cut (MAXCUT).** Given a graph $\mathcal{G} = \{\mathcal{V}, \mathcal{E}\}$, a cut $\mathcal{C} = \{\mathcal{S}, \mathcal{V}/\mathcal{S}\}$ is a partition of \mathcal{V} into two disjoint subsets \mathcal{S} and \mathcal{V}/\mathcal{S} . Its corresponding cut-set is the subset of edges $\mathcal{E}_c \in \mathcal{E}$ with one endpoint in \mathcal{S} and the other endpoint in \mathcal{V}/\mathcal{S} . The problem of maximum cut is to find such a cut \mathcal{C} , where the weights of its cut-set \mathcal{E}_c denoted as $\sum_{(u,v) \in \mathcal{E}_c} w(u,v)$ are maximized, where $w(u,v)$ denotes the weight of edge (u,v) .
- **Traveling Salesman Problem (TSP).** Given a collection of cities connected through routes, the traveling salesman problem is to find the shortest route that visits every city once and comes back to the starting city. It can be modeled as a graph $\mathcal{G} = \{\mathcal{V}, \mathcal{E}\}$, where nodes are the cities and edges are the routes connecting them. The distance between cities can be modeled as weights on the edges.
- **Maximal Independent Set (MIS).** Given a graph \mathcal{G} , an independent set is a subset of vertices $\mathcal{S} \subset \mathcal{V}$ where no pair of nodes is connected by an edge. The problem of maximal independent set is to find the independent set with the largest number of nodes.

Some of these problems can often be modeled as a node/edge annotation problem, where the goal is to tell whether a node/edge is in the solution or not. For example, the problem of minimum vertex cover (MVC) can be modeled as a node annotation problem (or a node classification problem), where the node in the solution is annotated as 1. In contrast, those not in the solution are annotated as 0. Similarly, the travel salesman problem can be modeled as a problem of node selection or edge annotation. Graph neural networks are suitable to tackle these problems, given rich training samples. However, directly tackling these problems as purely node/edge annotation tasks may lead to invalid solutions. For example, in the task of maximal independent set problem, two connected nodes might be annotated as 1 at the same time during the inference, which may lead to a invalid independent set. Hence, some search heuristics are usually utilized with graph neural networks to find valid solutions.

In (Khalil et al., 2017), these problems are modeled as a sequential node selection task, which is tackled with reinforcement learning. The graph neural network model is utilized to model the state representations for the deep reinforcement learning framework. A solution is constructed by sequentially adding nodes to a partial solution. These nodes are sequentially selected greedily by maximizing some evaluation functions in the reinforcement learning framework, which is used to measure the quality of the solution (or partial solution). After the nodes are chosen, a helper function is employed to organize them into a valid solution of given tasks. For example, for the MAXCUT task, given the selected set \mathcal{S} , its complimentary set \mathcal{V}/\mathcal{S} is found, and the maximum cut-set includes all edges with one endpoint in one set and the other endpoint in the other set.

Instead of sequentially choosing nodes with a reinforcement learning framework, the tasks are modeled as a node annotation task in (Li et al., 2018e). During the training stage, nodes in each training sample are annotated with 1 or 0, where 1 indicates that nodes are in the set of solutions. After training, given a new sample, the graph neural network model can output a probability score for each node, indicating how likely it should be included in the solution. Then a greedy search algorithm is proposed based on these probability scores to build valid solutions recursively. For example, for the MIS task, nodes are first sorted by the probability scores in descending order. Then we iterate all nodes in this order and label each node with 1 and its neighbors with 0. The process stops when we encounter the first node labeled with 0. Next, we remove all labeled nodes (labeled with 1 or 0) and use the remaining nodes to build an induced subgraph. We repeat the process on the induced subgraph. The entire process is terminated until all nodes in the graph are labeled.

In (Joshi et al., 2019), the graph neural network model is trained to annotate edges to solve the travel salesman problem. During training, edges in each training sample are annotated with 1 or 0, indicating whether the edge is in the solution or not. Then, during the inference stage, the model can predict probability scores for edges in the graph. These scores are combined with the beam search to find valid solutions for TSP.

15.3 Learning Program Representations

Machine learning techniques have been adopted to automate various tasks on source code, such as variable misuse detection and software vulnerability detection. A natural way to denote the source code is to treat it as “articles” in a specific language. Then we can transfer the techniques designed for NLP

to deal with source code. However, representing source code as a sequence of tokens usually fails to capture the syntactic and semantic relations in the code. Recently, there are increasing attempts to represent code as graphs and graph neural networks have been employed to learn representations to facilitate down-stream tasks. Next, we first briefly introduce how source code can be denoted as graphs. Then, we describe some downstream tasks and how graph neural networks can be employed to handle these tasks.

There are various ways to construct graphs from source code. Representative ones are listed below (Zhou et al., 2019):

- **Abstract Syntax Tree (AST).** One common graph representation for the program is the abstract syntax tree (AST). It encodes the abstract syntactic structure of the source code. Usually, AST is used by code parsers to understand the code structures and find syntactic errors. Nodes in AST consist of syntax nodes (corresponding to non-terminals in the programming language's grammar) and syntax tokens (corresponding to terminals). Directed edges are adopted to represent the child-parent relations.
- **Control Flow Graph (CFG).** The control flow graph describes all potential paths to be traversed in a program during the execution. CFGs consist of statements and conditions as nodes. The conditional statements such as *if* and *switch* are the key nodes of forming different paths. The edges in CFGs indicate the transfer of the control between statements.
- **Data Flow Graph (DFG).** A data flow graph describes how variables are used through the program. It has the variables as its nodes, and the edges represent any access or modifications to these variables.
- **Natural Code Sequence (NCS).** The NCS is a sequence of the source code, where the edges connect neighboring code tokens according to the order in the source code.

These graphs can further be combined to form a more comprehensive graph, which encodes both syntactic and semantic information about the program. Different tasks can be performed with graph neural networks based on the built graphs for a given program. Graph neural networks are usually utilized to learn node representations or graph representations, which are then employed to perform these tasks. There are tasks focusing on nodes in the graphs such as variable misuse detection in a program (Allamanis et al., 2017) and also tasks focusing on the entire program graph such as software vulnerability detection (Zhou et al., 2019).

15.4 Reasoning Interacting Dynamical Systems in Physics

Interacting systems are ubiquitous in nature, and dynamical systems in physics are one of the representatives. Inferring the future states or underlying properties of the dynamical system is challenging due to the complicated interactions between objects in the dynamical system. The objects and their relations in dynamical systems can be typically denoted as a graph, where the objects are the nodes, and the relations between them can be captured as edges. We introduce some dynamical systems in physics and then briefly describe how graph neural networks can be used to infer these dynamical systems.

- **N-body.** In the N-body domain, there are N objects. All N objects in this dynamic system exert gravitational forces to each other, which is dependent on their mass and pair-wise distance. As the relations are pair-wise, there are in total, $N(N - 1)$ relations, which can be modeled as a fully-connected graph. Predicting the dynamics of solar systems can be regarded as an N -body problem.
- **Bouncing balls.** In the domain of the bouncing ball, there are two types of objects, i.e., the balls and the walls. The balls are constantly moving, which can collide with other balls and the static walls. Assuming that there are, in total, N objects including both balls and walls, $N(N - 1)$ pair-wise relations exist, which again can be modeled as a fully-connected graph.
- **Charged particles.** In the charged particles domain, there are N particles, and each of them carries positive or negative charges. Each pair of particles interact with each other; hence, there are $N(N - 1)$ relations and the system can be modeled as a fully connected graph.

The goal of the task is to infer the future status, given the history (or the initial status) of the dynamical system. The status of the dynamical system can be represented by the trajectories of the objects $\mathcal{T} = \{\mathbf{x}_1, \dots, \mathbf{x}_N\}$, where $\mathbf{x}_i = \{\mathbf{x}_i^{(0)}, \dots, \mathbf{x}_i^{(t)}\}$ with $\mathbf{x}_i^{(t)}$ denoting the status of node i at time t . Usually, the status information about an object includes its positions or velocity.

In (Battaglia et al., 2016), a model named interaction network is proposed to model and predict the future status of the dynamical system. The model can be viewed as a specific type of graph neural networks. It is also based on passing messages through the graphs to update the node representations. Specifically, there are relation-centric and node-centric functions in the interaction network model, where the relation-centric function is adopted to model the effect of the interactions between nodes, while the node-centric function takes the output of the relation-centric function to update the status of the nodes. Hence, compared with the MPNN framework we introduced in Section 5.3.2, the relation-centric

function can be regarded as the message function while the node-centric function can be viewed as the update function. These functions are usually modeled with neural networks. Note that the interaction network can handle different types of objects and relations by designing various types of functions. A more general framework, named as graph networks, is proposed in (Battaglia et al., 2018).

The interaction network assumes that relations between the objects are known, which might not be practical. In (Kipf et al., 2018), a model is proposed to infer the types of relations while predicting the future status of the dynamical system. It takes the form of variational autoencoder, where both the encoder and decoder are modeled by graph neural networks. The encoder, which is applied to the original input graph \mathcal{G} , takes the observed trajectories (the history of the dynamical system) as input and predicts the types of relations. The graph with the information of relation types from the encoder is denoted as \mathcal{G}' . It is used as the input graph for the decoder. The decoder is also modeled with graph neural networks, and its goal is to predict the future status of the interacting system.

15.5 Conclusion

In this chapter, we discuss some advanced applications of graph neural networks. We introduced their usage to produce heuristics for NP-hard combinatorial optimizations on graphs such as minimum vertex cover, maximum cut, the traveling salesman problem, and maximal independent set. We illustrated how source code can be denoted as graphs and how graph neural networks can be leveraged to learn program representations to facilitating down-stream tasks. We also presented how to infer the future dynamics of interacting physical systems via graph neural networks.

15.6 Further Reading

Graph neural networks have been proven to be powerful in handling graph-structured data. They are continually being employed for new applications. In (Jeong et al., 2019), musical scores are denoted as graphs, and graph neural networks are applied to these graphs to render expressive piano performance. In (Zhang et al., 2019c), graph neural networks are adopted to speed up the process of distributed circuit design. In (Rusek et al., 2019), graph neural net-

works are utilized to facilitate network modeling and optimization in software defined networks (SDN).

Bibliography

- Abadi, Martín, Agarwal, Ashish, Barham, Paul, Brevdo, Eugene, Chen, Zhifeng, Citro, Craig, Corrado, Greg S., Davis, Andy, Dean, Jeffrey, Devin, Matthieu, Ghemawat, Sanjay, Goodfellow, Ian, Harp, Andrew, Irving, Geoffrey, Isard, Michael, Jia, Yangqing, Jozefowicz, Rafal, Kaiser, Lukasz, Kudlur, Manjunath, Levenberg, Josh, Mané, Dandelion, Monga, Rajat, Moore, Sherry, Murray, Derek, Olah, Chris, Schuster, Mike, Shlens, Jonathon, Steiner, Benoit, Sutskever, Ilya, Talwar, Kunal, Tucker, Paul, Vanhoucke, Vincent, Vasudevan, Vijay, Viégas, Fernanda, Vinyals, Oriol, Warden, Pete, Wattenberg, Martin, Wicke, Martin, Yu, Yuan, and Zheng, Xiaoqiang. 2015. *TensorFlow: Large-Scale Machine Learning on Heterogeneous Systems*. Software available from tensorflow.org.
- Adamic, Lada A, and Adar, Eytan. 2003. Friends and neighbors on the web. *Social networks*, **25**(3), 211–230.
- Afsar Minhas, Fayyaz ul Amir, Geiss, Brian J, and Ben-Hur, Asa. 2014. PAIRpred: Partner-specific prediction of interacting residues from sequence and structure. *Proteins: Structure, Function, and Bioinformatics*, **82**(7), 1142–1155.
- Aggarwal, Charu C. 2018. Neural networks and deep learning. *Springer*, **10**, 978–3.
- Allamanis, Miltiadis, Brockschmidt, Marc, and Khademi, Mahmoud. 2017. Learning to represent programs with graphs. *arXiv preprint arXiv:1711.00740*.
- Andersen, Reid, Chung, Fan, and Lang, Kevin. 2006. Local graph partitioning using pagerank vectors. Pages 475–486 of: *2006 47th Annual IEEE Symposium on Foundations of Computer Science (FOCS'06)*. IEEE.
- Atwood, James, and Towsley, Don. 2016. Diffusion-convolutional neural networks. Pages 1993–2001 of: *Advances in neural information processing systems*.
- Babai, László. 2016. Graph isomorphism in quasipolynomial time. Pages 684–697 of: *Proceedings of the forty-eighth annual ACM symposium on Theory of Computing*.
- Bahdanau, Dzmitry, Cho, Kyunghyun, and Bengio, Yoshua. 2014. Neural machine translation by jointly learning to align and translate. *arXiv preprint arXiv:1409.0473*.
- Bai, Song, Zhang, Feihu, and Torr, Philip HS. 2019. Hypergraph convolution and hypergraph attention. *arXiv preprint arXiv:1901.08150*.
- Banarescu, Laura, Bonial, Claire, Cai, Shu, Georgescu, Madalina, Griffitt, Kira, Hermjakob, Ulf, Knight, Kevin, Koehn, Philipp, Palmer, Martha, and Schneider, Nathan. 2013. Abstract meaning representation for sembanking. Pages 178–186

- of: *Proceedings of the 7th Linguistic Annotation Workshop and Interoperability with Discourse*.
- Bastings, Joost, Titov, Ivan, Aziz, Wilker, Marcheggiani, Diego, and Sima'an, Khalil. 2017. Graph convolutional encoders for syntax-aware neural machine translation. *arXiv preprint arXiv:1704.04675*.
- Battaglia, Peter, Pascanu, Razvan, Lai, Matthew, Rezendes, Danilo Jimenez, et al. 2016. Interaction networks for learning about objects, relations and physics. Pages 4502–4510 of: *Advances in neural information processing systems*.
- Battaglia, Peter W, Hamrick, Jessica B, Bapst, Victor, Sanchez-Gonzalez, Alvaro, Zambaldi, Vinicius, Malinowski, Mateusz, Tacchetti, Andrea, Raposo, David, Santoro, Adam, Faulkner, Ryan, et al. 2018. Relational inductive biases, deep learning, and graph networks. *arXiv preprint arXiv:1806.01261*.
- Baytas, Inci M, Xiao, Cao, Wang, Fei, Jain, Anil K, and Zhou, Jiayu. 2018. Heterogeneous Hyper-Network Embedding. Pages 875–880 of: *2018 IEEE International Conference on Data Mining (ICDM)*. IEEE.
- Beck, Daniel, Haffari, Gholamreza, and Cohn, Trevor. 2018. Graph-to-Sequence Learning using Gated Graph Neural Networks. Pages 273–283 of: *Proceedings of the 56th Annual Meeting of the Association for Computational Linguistics (Volume 1: Long Papers)*.
- Belkin, Mikhail, and Niyogi, Partha. 2003. Laplacian eigenmaps for dimensionality reduction and data representation. *Neural computation*, **15**(6), 1373–1396.
- Berg, Rianne van den, Kipf, Thomas N, and Welling, Max. 2017. Graph convolutional matrix completion. *arXiv preprint arXiv:1706.02263*.
- Berlusconi, Giulia, Calderoni, Francesco, Parolini, Nicola, Verani, Marco, and Piccardi, Carlo. 2016. Link prediction in criminal networks: A tool for criminal intelligence analysis. *PloS one*, **11**(4), e0154244.
- Bhagat, Smriti, Cormode, Graham, and Muthukrishnan, S. 2011. Node classification in social networks. Pages 115–148 of: *Social network data analytics*. Springer.
- Bishop, Christopher M. 2006. *Pattern recognition and machine learning*. Springer.
- Bonacich, Phillip. 1972. Factoring and weighting approaches to status scores and clique identification. *Journal of mathematical sociology*, **2**(1), 113–120.
- Bonacich, Phillip. 2007. Some unique properties of eigenvector centrality. *Social networks*, **29**(4), 555–564.
- Bonchev, Danail. 1991. *Chemical graph theory: introduction and fundamentals*. Vol. 1. CRC Press.
- Bondy, John Adrian, et al. *Graph theory with applications*. Vol. 290.
- Borgatti, Stephen P, Mehra, Ajay, Brass, Daniel J, and Labianca, Giuseppe. 2009. Network analysis in the social sciences. *science*, **323**(5916), 892–895.
- Bourigault, Simon, Lagnier, Cedric, Lamprier, Sylvain, Denoyer, Ludovic, and Gallinari, Patrick. 2014. Learning social network embeddings for predicting information diffusion. Pages 393–402 of: *Proceedings of the 7th ACM international conference on Web search and data mining*.
- Boyd, Stephen, Boyd, Stephen P, and Vandenberghe, Lieven. 2004. *Convex optimization*. Cambridge university press.
- Bracewell, Ronald Newbold. *The Fourier transform and its applications*. Vol. 31999.

- Bruna, Joan, Zaremba, Wojciech, Szlam, Arthur, and LeCun, Yann. 2013. Spectral networks and locally connected networks on graphs. *arXiv preprint arXiv:1312.6203*.
- Cai, Hongyun, Zheng, Vincent W, and Chang, Kevin Chen-Chuan. 2018. A comprehensive survey of graph embedding: Problems, techniques, and applications. *IEEE Transactions on Knowledge and Data Engineering*, **30**(9), 1616–1637.
- Cai, Jin-Yi, Fürer, Martin, and Immerman, Neil. 1992. An optimal lower bound on the number of variables for graph identification. *Combinatorica*, **12**(4), 389–410.
- Cao, Shaosheng, Lu, Wei, and Xu, Qionghai. 2015. Grarep: Learning graph representations with global structural information. Pages 891–900 of: *Proceedings of the 24th ACM international on conference on information and knowledge management*.
- Cao, Shaosheng, Lu, Wei, and Xu, Qionghai. 2016. Deep neural networks for learning graph representations. In: *Thirtieth AAAI conference on artificial intelligence*.
- Cao, Yu, Fang, Meng, and Tao, Dacheng. 2019. BAG: Bi-directional Attention Entity Graph Convolutional Network for Multi-hop Reasoning Question Answering. Pages 357–362 of: *Proceedings of the 2019 Conference of the North American Chapter of the Association for Computational Linguistics: Human Language Technologies, Volume 1 (Long and Short Papers)*.
- Carlini, Nicholas, and Wagner, David. 2017. Towards evaluating the robustness of neural networks. Pages 39–57 of: *2017 IEEE Symposium on Security and Privacy (SP)*. IEEE.
- Cartwright, Dorwin, and Harary, Frank. 1956. Structural balance: a generalization of Heider's theory. *Psychological review*, **63**(5), 277.
- Cauchy, Augustin. Méthode générale pour la résolution des systemes d'équations simultanées.
- Chami, Ines, Ying, Zitao, Ré, Christopher, and Leskovec, Jure. 2019. Hyperbolic graph convolutional neural networks. Pages 4868–4879 of: *Advances in neural information processing systems*.
- Chan, T-H Hubert, and Liang, Zhibin. 2019. Generalizing the hypergraph Laplacian via a diffusion process with mediators. *Theoretical Computer Science*.
- Chan, T-H Hubert, Louis, Anand, Tang, Zhihao Gavin, and Zhang, Chenzi. 2018. Spectral properties of hypergraph Laplacian and approximation algorithms. *Journal of the ACM (JACM)*, **65**(3), 15.
- Chang, Shiyu, Han, Wei, Tang, Jiliang, Qi, Guo-Jun, Aggarwal, Charu C, and Huang, Thomas S. 2015. Heterogeneous network embedding via deep architectures. Pages 119–128 of: *Proceedings of the 21th ACM SIGKDD International Conference on Knowledge Discovery and Data Mining*.
- Chaudhary, Anshika, Mittal, Himangi, and Arora, Anuja. 2019. Anomaly Detection Using Graph Neural Networks. Pages 346–350 of: *2019 International Conference on Machine Learning, Big Data, Cloud and Parallel Computing (COMITCon)*. IEEE.
- Chen, Jianfei, Zhu, Jun, and Song, Le. 2018a. Stochastic Training of Graph Convolutional Networks with Variance Reduction. Pages 941–949 of: *International Conference on Machine Learning*.
- Chen, Jie, Ma, Tengfei, and Xiao, Cao. 2018b. Fastgcn: fast learning with graph convolutional networks via importance sampling. *arXiv preprint arXiv:1801.10247*.

- Chen, Tianshui, Yu, Weihao, Chen, Riquan, and Lin, Liang. 2019a. Knowledge-embedded routing network for scene graph generation. Pages 6163–6171 of: *Proceedings of the IEEE Conference on Computer Vision and Pattern Recognition*.
- Chen, Ting, and Sun, Yizhou. 2017. Task-guided and path-augmented heterogeneous network embedding for author identification. Pages 295–304 of: *Proceedings of the Tenth ACM International Conference on Web Search and Data Mining*.
- Chen, Xia, Yu, Guoxian, Wang, Jun, Domeniconi, Carlotta, Li, Zhao, and Zhang, Xi-angliang. 2019b. ActiveHNE: Active Heterogeneous Network Embedding. *arXiv preprint arXiv:1905.05659*.
- Chen, Zhao-Min, Wei, Xiu-Shen, Wang, Peng, and Guo, Yanwen. 2019c. Multi-Label Image Recognition with Graph Convolutional Networks. Pages 5177–5186 of: *Proceedings of the IEEE Conference on Computer Vision and Pattern Recognition*.
- Chen, Zhengdao, Li, Xiang, and Bruna, Joan. 2017. Supervised community detection with line graph neural networks. *arXiv preprint arXiv:1705.08415*.
- Cheng, Kewei, Li, Jundong, and Liu, Huan. 2017. Unsupervised feature selection in signed social networks. Pages 777–786 of: *Proceedings of the 23rd ACM SIGKDD International Conference on Knowledge Discovery and Data Mining*.
- Chiang, Wei-Lin, Liu, Xuanqing, Si, Si, Li, Yang, Bengio, Samy, and Hsieh, Cho-Jui. 2019. Cluster-gcn: An efficient algorithm for training deep and large graph convolutional networks. Pages 257–266 of: *Proceedings of the 25th ACM SIGKDD International Conference on Knowledge Discovery & Data Mining*.
- Cho, Kyunghyun, Van Merriënboer, Bart, Gulcehre, Caglar, Bahdanau, Dzmitry, Bougares, Fethi, Schwenk, Holger, and Bengio, Yoshua. 2014a. Learning phrase representations using RNN encoder-decoder for statistical machine translation. *arXiv preprint arXiv:1406.1078*.
- Cho, Minsu, Sun, Jian, Duchenne, Olivier, and Ponce, Jean. 2014b. Finding matches in a haystack: A max-pooling strategy for graph matching in the presence of outliers. Pages 2083–2090 of: *Proceedings of the IEEE Conference on Computer Vision and Pattern Recognition*.
- Choi, Edward, Xu, Zhen, Li, Yujia, Dusenberry, Michael, Flores, Gerardo, Xue, Emily, and Dai, Andrew. 2020. Learning the Graphical Structure of Electronic Health Records with Graph Convolutional Transformer. Pages 606–613 of: *Proceedings of the AAAI Conference on Artificial Intelligence*, vol. 34.
- Chung, Fan RK, and Graham, Fan Chung. 1997. *Spectral graph theory*. American Mathematical Soc.
- Cohen, Marco Damonte Shay B. 2019. Structural Neural Encoders for AMR-to-text Generation. Pages 3649–3658 of: *Proceedings of NAACL-HLT*.
- Cui, Peng, Wang, Xiao, Pei, Jian, and Zhu, Wenwu. 2018. A survey on network embedding. *IEEE Transactions on Knowledge and Data Engineering*, **31**(5), 833–852.
- Cygan, Marek, Pilipczuk, Marcin, Pilipczuk, Michał, and Wojtaszczyk, Jakub Onufry. 2012. Sitting closer to friends than enemies, revisited. Pages 296–307 of: *International Symposium on Mathematical Foundations of Computer Science*. Springer.
- Dahl, George, Ranzato, Marc’Aurelio, Mohamed, Abdel-rahman, and Hinton, Geoffrey E. 2010. Phone recognition with the mean-covariance restricted Boltzmann machine. Pages 469–477 of: *Advances in neural information processing systems*.

- Dai, Hanjun, Li, Hui, Tian, Tian, Huang, Xin, Wang, Lin, Zhu, Jun, and Song, Le. 2018. Adversarial Attack on Graph Structured Data. In: *Proceedings of the 35th International Conference on Machine Learning, PMLR*, vol. 80.
- De Cao, Nicola, and Kipf, Thomas. 2018. MolGAN: An implicit generative model for small molecular graphs. *arXiv preprint arXiv:1805.11973*.
- De Cao, Nicola, Aziz, Wilker, and Titov, Ivan. 2019. Question Answering by Reasoning Across Documents with Graph Convolutional Networks. Pages 2306–2317 of: *Proceedings of the 2019 Conference of the North American Chapter of the Association for Computational Linguistics: Human Language Technologies, Volume 1 (Long and Short Papers)*.
- Deerwester, Scott, Dumais, Susan T, Furnas, George W, Landauer, Thomas K, and Harshman, Richard. 1990. Indexing by latent semantic analysis. *Journal of the American society for information science*, **41**(6), 391–407.
- Defferrard, Michaël, Bresson, Xavier, and Vandergheynst, Pierre. 2016. Convolutional neural networks on graphs with fast localized spectral filtering. Pages 3844–3852 of: *Advances in neural information processing systems*.
- Deng, Li, and Liu, Yang. 2018. *Deep learning in natural language processing*. Springer.
- Deng, Li, Seltzer, Michael L, Yu, Dong, Acero, Alex, Mohamed, Abdel-rahman, and Hinton, Geoff. 2010. Binary coding of speech spectrograms using a deep auto-encoder. In: *Eleventh Annual Conference of the International Speech Communication Association*.
- Derr, Tyler, Ma, Yao, and Tang, Jiliang. 2018. Signed graph convolutional networks. Pages 929–934 of: *2018 IEEE International Conference on Data Mining (ICDM)*. IEEE.
- Devlin, Jacob, Chang, Ming-Wei, Lee, Kenton, and Toutanova, Kristina. 2018. Bert: Pre-training of deep bidirectional transformers for language understanding. *arXiv preprint arXiv:1810.04805*.
- Dhillon, Inderjit S, Guan, Yuqiang, and Kulis, Brian. 2007. Weighted graph cuts without eigenvectors a multilevel approach. *IEEE transactions on pattern analysis and machine intelligence*, **29**(11), 1944–1957.
- Di Martino, Adriana, Yan, Chao-Gan, Li, Qingyang, Denio, Erin, Castellanos, Francisco X, Alaerts, Kaat, Anderson, Jeffrey S, Assaf, Michal, Bookheimer, Susan Y, Dapretto, Mirella, et al. 2014. The autism brain imaging data exchange: towards a large-scale evaluation of the intrinsic brain architecture in autism. *Molecular psychiatry*, **19**(6), 659–667.
- Dong, Yuxiao, Chawla, Nitesh V, and Swami, Ananthram. 2017. metapath2vec: Scalable representation learning for heterogeneous networks. Pages 135–144 of: *Proceedings of the 23rd ACM SIGKDD international conference on knowledge discovery and data mining*. ACM.
- Duchi, John, Hazan, Elad, and Singer, Yoram. 2011. Adaptive subgradient methods for online learning and stochastic optimization. *Journal of Machine Learning Research*, **12**(Jul), 2121–2159.
- Duvenaud, David K, Maclaurin, Dougal, Iparraguirre, Jorge, Bombarell, Rafael, Hirzel, Timothy, Aspuru-Guzik, Alán, and Adams, Ryan P. 2015. Convolutional networks on graphs for learning molecular fingerprints. Pages 2224–2232 of: *Advances in neural information processing systems*.

- Entezari, Negin, Al-Sayouri, Saba A, Darvishzadeh, Amirali, and Papalexakis, Evangelos E. 2020. All You Need Is Low (Rank) Defending Against Adversarial Attacks on Graphs. Pages 169–177 of: *Proceedings of the 13th International Conference on Web Search and Data Mining*.
- Fan, Wenqi, Ma, Yao, Li, Qing, He, Yuan, Zhao, Eric, Tang, Jiliang, and Yin, Dawei. 2019. Graph Neural Networks for Social Recommendation. Pages 417–426 of: *The World Wide Web Conference*. ACM.
- Feller, William. 1957. An introduction to probability theory and its applications. *aitp*.
- Feng, Fuli, He, Xiangnan, Tang, Jie, and Chua, Tat-Seng. 2019a. Graph adversarial training: Dynamically regularizing based on graph structure. *IEEE Transactions on Knowledge and Data Engineering*.
- Feng, Yifan, You, Haoxuan, Zhang, Zizhao, Ji, Rongrong, and Gao, Yue. 2019b. Hypergraph neural networks. Pages 3558–3565 of: *Proceedings of the AAAI Conference on Artificial Intelligence*, vol. 33.
- Fernandes, Patrick, Allamanis, Miltiadis, and Brockschmidt, Marc. 2018. Structured neural summarization. *arXiv preprint arXiv:1811.01824*.
- Fey, Matthias, and Lenssen, Jan E. 2019. Fast Graph Representation Learning with PyTorch Geometric. In: *ICLR Workshop on Representation Learning on Graphs and Manifolds*.
- Finn, Chelsea, Abbeel, Pieter, and Levine, Sergey. 2017. Model-agnostic meta-learning for fast adaptation of deep networks. Pages 1126–1135 of: *Proceedings of the 34th International Conference on Machine Learning-Volume 70*. JMLR. org.
- Fouss, Francois, Pirotte, Alain, Renders, Jean-Michel, and Saerens, Marco. 2007. Random-walk computation of similarities between nodes of a graph with application to collaborative recommendation. *IEEE Transactions on knowledge and data engineering*, **19**(3), 355–369.
- Fout, Alex, Byrd, Jonathon, Shariat, Basir, and Ben-Hur, Asa. 2017. Protein interface prediction using graph convolutional networks. Pages 6530–6539 of: *Advances in Neural Information Processing Systems*.
- Frobenius, Georg, Frobenius, Ferdinand Georg, Frobenius, Ferdinand Georg, Frobenius, Ferdinand Georg, and Mathematician, Germany. 1912. Über Matrizen aus nicht negativen Elementen.
- Fu, Tsu-Jui, Li, Peng-Hsuan, and Ma, Wei-Yun. 2019. GraphRel: Modeling text as relational graphs for joint entity and relation extraction. Pages 1409–1418 of: *Proceedings of the 57th Annual Meeting of the Association for Computational Linguistics*.
- Gao, Hongyang, and Ji, Shuiwang. 2019. Graph U-Nets. Pages 2083–2092 of: Chaudhuri, Kamalika, and Salakhutdinov, Ruslan (eds), *Proceedings of the 36th International Conference on Machine Learning, ICML 2019, 9-15 June 2019, Long Beach, California, USA*. Proceedings of Machine Learning Research, vol. 97. PMLR.
- Gao, Hongyang, Wang, Zhengyang, and Ji, Shuiwang. 2018a. Large-scale learnable graph convolutional networks. Pages 1416–1424 of: *Proceedings of the 24th ACM SIGKDD International Conference on Knowledge Discovery & Data Mining*.
- Gao, Hongyang, Wang, Zhengyang, and Ji, Shuiwang. 2020. Kronecker Attention Networks. Pages 229–237 of: *Proceedings of the 26th ACM SIGKDD International Conference on Knowledge Discovery & Data Mining*.

- Gao, Ming, Chen, Leihui, He, Xiangnan, and Zhou, Aoying. 2018b. Bine: Bipartite network embedding. Pages 715–724 of: *The 41st International ACM SIGIR Conference on Research & Development in Information Retrieval*.
- Garey, Michael R, and Johnson, David S. *Computers and intractability*. Vol. 174.
- Gidaris, Spyros, and Komodakis, Nikos. 2019. Generating classification weights with gnn denoising autoencoders for few-shot learning. Pages 21–30 of: *Proceedings of the IEEE Conference on Computer Vision and Pattern Recognition*.
- Gilmer, Justin, Schoenholz, Samuel S., Riley, Patrick F., Vinyals, Oriol, and Dahl, George E. 2017. Neural Message Passing for Quantum Chemistry. Pages 1263–1272 of: Precup, Doina, and Teh, Yee Whye (eds), *Proceedings of the 34th International Conference on Machine Learning, ICML 2017, Sydney, NSW, Australia, 6-11 August 2017*. Proceedings of Machine Learning Research, vol. 70. PMLR.
- Goldberg, David, Nichols, David, Oki, Brian M, and Terry, Douglas. 1992. Using collaborative filtering to weave an information tapestry. *Communications of the ACM*, **35**(12), 61–70.
- Goldberg, Ken, Roeder, Theresa, Gupta, Dhruv, and Perkins, Chris. 2001. Eigentaste: A constant time collaborative filtering algorithm. *information retrieval*, **4**(2), 133–151.
- Goldberg, Yoav. 2016. A primer on neural network models for natural language processing. *Journal of Artificial Intelligence Research*, **57**, 345–420.
- Goodfellow, Ian, Pouget-Abadie, Jean, Mirza, Mehdi, Xu, Bing, Warde-Farley, David, Ozair, Sherjil, Courville, Aaron, and Bengio, Yoshua. 2014a. Generative adversarial nets. Pages 2672–2680 of: *Advances in neural information processing systems*.
- Goodfellow, Ian, Bengio, Yoshua, and Courville, Aaron. 2016. *Deep learning*.
- Goodfellow, Ian J, Shlens, Jonathon, and Szegedy, Christian. 2014b. Explaining and harnessing adversarial examples. *arXiv preprint arXiv:1412.6572*.
- Goyal, Palash, and Ferrara, Emilio. 2018. Graph embedding techniques, applications, and performance: A survey. *Knowledge-Based Systems*, **151**, 78–94.
- Grover, Aditya, and Leskovec, Jure. 2016. node2vec: Scalable feature learning for networks. Pages 855–864 of: *Proceedings of the 22nd ACM SIGKDD international conference on Knowledge discovery and data mining*. ACM.
- Gu, Quanquan, and Han, Jiawei. 2011. Towards feature selection in network. Pages 1175–1184 of: *Proceedings of the 20th ACM international conference on Information and knowledge management*.
- Gu, Yupeng, Sun, Yizhou, Li, Yanen, and Yang, Yang. 2018. Rare: Social rank regulated large-scale network embedding. Pages 359–368 of: *Proceedings of the 2018 World Wide Web Conference*.
- Guo, Zhijiang, Zhang, Yan, and Lu, Wei. 2019. Attention Guided Graph Convolutional Networks for Relation Extraction. *arXiv preprint arXiv:1906.07510*.
- Gutmann, Michael U, and Hyvärinen, Aapo. 2012. Noise-contrastive estimation of unnormalized statistical models, with applications to natural image statistics. *Journal of Machine Learning Research*, **13**(Feb), 307–361.
- Hagberg, Aric, Swart, Pieter, and S Chult, Daniel. 2008. *Exploring network structure, dynamics, and function using NetworkX*. Tech. rept. Los Alamos National Lab.(LANL), Los Alamos, NM (United States).

- Hamaguchi, Takuo, Oiwa, Hidekazu, Shimbo, Masashi, and Matsumoto, Yuji. 2017. Knowledge transfer for out-of-knowledge-base entities: a graph neural network approach. Pages 1802–1808 of: *Proceedings of the 26th International Joint Conference on Artificial Intelligence*. AAAI Press.
- Hamilton, Will, Ying, Zitao, and Leskovec, Jure. 2017a. Inductive representation learning on large graphs. Pages 1024–1034 of: *Advances in Neural Information Processing Systems*.
- Hamilton, William L, Ying, Rex, and Leskovec, Jure. 2017b. Representation learning on graphs: Methods and applications. *arXiv preprint arXiv:1709.05584*.
- Han, Jiangfan, Luo, Ping, and Wang, Xiaogang. 2019. Deep self-learning from noisy labels. Pages 5138–5147 of: *Proceedings of the IEEE International Conference on Computer Vision*.
- Han, Jiawei, Pei, Jian, and Kamber, Micheline. 2011. *Data mining: concepts and techniques*. Elsevier.
- He, Chaoyang, Xie, Tian, Rong, Yu, Huang, Wenbing, Li, Yanfang, Huang, Junzhou, Ren, Xiang, and Shahabi, Cyrus. 2019. Bipartite Graph Neural Networks for Efficient Node Representation Learning. *arXiv preprint arXiv:1906.11994*.
- He, Kaiming, Zhang, Xiangyu, Ren, Shaoqing, and Sun, Jian. 2016. Deep residual learning for image recognition. Pages 770–778 of: *Proceedings of the IEEE conference on computer vision and pattern recognition*.
- Heider, Fritz. 1946. Attitudes and cognitive organization. *The Journal of psychology*, **21**(1), 107–112.
- Hochreiter, Sepp, and Schmidhuber, Jürgen. 1997. Long short-term memory. *Neural computation*, **9**(8), 1735–1780.
- Hoffman, Kenneth, and Kunze, Ray. Linear algebra. 1971. *Englewood Cliffs, New Jersey*.
- Hu, Weihua, Liu, Bowen, Gomes, Joseph, Zitnik, Marinka, Liang, Percy, Pande, Vijay, and Leskovec, Jure. 2019. Pre-training graph neural networks. *arXiv preprint arXiv:1905.12265*.
- Hu, Ziniu, Dong, Yuxiao, Wang, Kuansan, Chang, Kai-Wei, and Sun, Yizhou. 2020. GPT-GNN: Generative Pre-Training of Graph Neural Networks. *arXiv preprint arXiv:2006.15437*.
- Huang, Qiang, Xia, Tingyu, Sun, Huiyan, Yamada, Makoto, and Chang, Yi. 2020. Unsupervised Nonlinear Feature Selection from High-Dimensional Signed Networks. Pages 4182–4189 of: *AAAI*.
- Huang, Wenbing, Zhang, Tong, Rong, Yu, and Huang, Junzhou. 2018. Adaptive sampling towards fast graph representation learning. Pages 4558–4567 of: *Advances in Neural Information Processing Systems*.
- Ioffe, Sergey, and Szegedy, Christian. 2015. Batch normalization: Accelerating deep network training by reducing internal covariate shift. *arXiv preprint arXiv:1502.03167*.
- Jeong, Dasaem, Kwon, Taegyun, Kim, Yoojin, and Nam, Juhan. 2019. Graph neural network for music score data and modeling expressive piano performance. Pages 3060–3070 of: *International Conference on Machine Learning*.
- Jiang, Jianwen, Wei, Yuxuan, Feng, Yifan, Cao, Jingxuan, and Gao, Yue. 2019. Dynamic Hypergraph Neural Networks. Pages 2635–2641 of: *IJCAI*.

- Jin, Hongwei, and Zhang, Xinhua. Latent adversarial training of graph convolution networks.
- Jin, Wei, Li, Yaxin, Xu, Han, Wang, Yiqi, and Tang, Jiliang. 2020a. Adversarial Attacks and Defenses on Graphs: A Review and Empirical Study. *arXiv preprint arXiv:2003.00653*.
- Jin, Wei, Ma, Yao, Liu, Xiaorui, Tang, Xianfeng, Wang, Suhang, and Tang, Jiliang. 2020b. Graph Structure Learning for Robust Graph Neural Networks. *arXiv preprint arXiv:2005.10203*.
- Jin, Wei, Derr, Tyler, Liu, Haochen, Wang, Yiqi, Wang, Suhang, Liu, Zitao, and Tang, Jiliang. 2020c. Self-supervised Learning on Graphs: Deep Insights and New Direction. *arXiv preprint arXiv:2006.10141*.
- Jin, Wengong, Barzilay, Regina, and Jaakkola, Tommi. 2018. Junction tree variational autoencoder for molecular graph generation. *arXiv preprint arXiv:1802.04364*.
- Joshi, Chaitanya K, Laurent, Thomas, and Bresson, Xavier. 2019. An efficient graph convolutional network technique for the travelling salesman problem. *arXiv preprint arXiv:1906.01227*.
- Joyce, James M. 2011. *Kullback-Leibler Divergence*.
- Jurafsky, Daniel, and Martin, James H. *Speech and Language Processing: An Introduction to Natural Language Processing, Computational Linguistics, and Speech Recognition*.
- Kamath, Uday, Liu, John, and Whitaker, James. 2019. *Deep learning for nlp and speech recognition*. Vol. 84. Springer.
- Kampffmeyer, Michael, Chen, Yinbo, Liang, Xiaodan, Wang, Hao, Zhang, Yujia, and Xing, Eric P. 2019. Rethinking knowledge graph propagation for zero-shot learning. Pages 11487–11496 of: *Proceedings of the IEEE Conference on Computer Vision and Pattern Recognition*.
- Kana, Rajesh K, Uddin, Lucina Q, Kenet, Tal, Chugani, Diane, and Müller, Ralph-Axel. 2014. Brain connectivity in autism. *Frontiers in Human Neuroscience*, **8**, 349.
- Karypis, George, and Kumar, Vipin. 1998. A fast and high quality multilevel scheme for partitioning irregular graphs. *SIAM Journal on scientific Computing*, **20**(1), 359–392.
- Khademi, Mahmoud, and Schulte, Oliver. 2020. Deep Generative Probabilistic Graph Neural Networks for Scene Graph Generation. Pages 11237–11245 of: *AAAI*.
- Khalil, Elias, Dai, Hanjun, Zhang, Yuyu, Dilkina, Bistra, and Song, Le. 2017. Learning combinatorial optimization algorithms over graphs. Pages 6348–6358 of: *Advances in Neural Information Processing Systems*.
- Kingma, Diederik P, and Ba, Jimmy. 2014. Adam: A method for stochastic optimization. *arXiv preprint arXiv:1412.6980*.
- Kingma, Diederik P, and Welling, Max. 2013. Auto-encoding variational bayes. *arXiv preprint arXiv:1312.6114*.
- Kipf, Thomas, Fetaya, Ethan, Wang, Kuan-Chieh, Welling, Max, and Zemel, Richard. 2018. Neural relational inference for interacting systems. *arXiv preprint arXiv:1802.04687*.
- Kipf, Thomas N, and Welling, Max. 2016a. Semi-supervised classification with graph convolutional networks. *arXiv preprint arXiv:1609.02907*.
- Kipf, Thomas N, and Welling, Max. 2016b. Variational graph auto-encoders. *arXiv preprint arXiv:1611.07308*.

- Koren, Yehuda, Bell, Robert, and Volinsky, Chris. 2009. Matrix factorization techniques for recommender systems. *Computer*, **42**(8), 30–37.
- Krizhevsky, Alex, Sutskever, Ilya, and Hinton, Geoffrey E. 2012. Imagenet classification with deep convolutional neural networks. Pages 1097–1105 of: *Advances in neural information processing systems*.
- Kuhn, Michael, Letunic, Ivica, Jensen, Lars Juhl, and Bork, Peer. 2016. The SIDER database of drugs and side effects. *Nucleic acids research*, **44**(D1), D1075–D1079.
- Kunegis, Jérôme, Lommatzsch, Andreas, and Bauckhage, Christian. 2009. The slashdot zoo: mining a social network with negative edges. Pages 741–750 of: *Proceedings of the 18th international conference on World wide web*. ACM.
- Lai, Yi-An, Hsu, Chin-Chi, Chen, Wen Hao, Yeh, Mi-Yen, and Lin, Shou-De. 2017. Prune: Preserving proximity and global ranking for network embedding. Pages 5257–5266 of: *Advances in neural information processing systems*.
- Le Cun, Yann, and Fogelman-Soulié, Françoise. 1987. Modèles connexionnistes de l'apprentissage. *Intellectica*, **2**(1), 114–143.
- Lee, John Boaz, Rossi, Ryan, and Kong, Xiangnan. 2018. Graph classification using structural attention. Pages 1666–1674 of: *Proceedings of the 24th ACM SIGKDD International Conference on Knowledge Discovery & Data Mining*.
- Lee, Junhyun, Lee, Inyeop, and Kang, Jaewoo. 2019. Self-Attention Graph Pooling. Pages 3734–3743 of: Chaudhuri, Kamalika, and Salakhutdinov, Ruslan (eds), *Proceedings of the 36th International Conference on Machine Learning, ICML 2019, 9-15 June 2019, Long Beach, California, USA*. Proceedings of Machine Learning Research, vol. 97. PMLR.
- Lee, Kenton, He, Luheng, Lewis, Mike, and Zettlemoyer, Luke. 2017. End-to-end neural coreference resolution. *arXiv preprint arXiv:1707.07045*.
- Leskovec, Jure, and Krevl, Andrej. 2014. *SNAP Datasets: Stanford Large Network Dataset Collection*.
- Leskovec, Jure, and Sosič, Rok. 2016. SNAP: A General-Purpose Network Analysis and Graph-Mining Library. *ACM Transactions on Intelligent Systems and Technology (TIST)*, **8**(1), 1.
- Leskovec, Jure, Huttenlocher, Daniel, and Kleinberg, Jon. 2010a. Predicting positive and negative links in online social networks. Pages 641–650 of: *Proceedings of the 19th international conference on World wide web*. ACM.
- Leskovec, Jure, Huttenlocher, Daniel, and Kleinberg, Jon. 2010b. Signed networks in social media. Pages 1361–1370 of: *Proceedings of the SIGCHI conference on human factors in computing systems*. ACM.
- Li, Chang, and Goldwasser, Dan. 2019. Encoding Social Information with Graph Convolutional Networks for Political Perspective Detection in News Media. Pages 2594–2604 of: *Proceedings of the 57th Annual Meeting of the Association for Computational Linguistics*.
- Li, Chaolong, Cui, Zhen, Zheng, Wenming, Xu, Chunyan, and Yang, Jian. 2018a. Spatio-temporal graph convolution for skeleton based action recognition. In: *Thirty-Second AAAI Conference on Artificial Intelligence*.
- Li, Chunyan, Liu, Hongju, Hu, Qian, Que, Jinlong, and Yao, Junfeng. 2019a. A novel computational model for predicting microRNA–disease associations based on heterogeneous graph convolutional networks. *Cells*, **8**(9), 977.

- Li, Jundong, Hu, Xia, Jian, Ling, and Liu, Huan. 2016. Toward time-evolving feature selection on dynamic networks. Pages 1003–1008 of: *2016 IEEE 16th International Conference on Data Mining (ICDM)*. IEEE.
- Li, Jundong, Dani, Harsh, Hu, Xia, Tang, Jiliang, Chang, Yi, and Liu, Huan. 2017a. Attributed network embedding for learning in a dynamic environment. Pages 387–396 of: *Proceedings of the 2017 ACM on Conference on Information and Knowledge Management*. ACM.
- Li, Jundong, Cheng, Kewei, Wang, Suhang, Morstatter, Fred, Trevino, Robert P, Tang, Jiliang, and Liu, Huan. 2017b. Feature selection: A data perspective. *ACM Computing Surveys (CSUR)*, **50**(6), 1–45.
- Li, Jundong, Guo, Ruocheng, Liu, Chenghao, and Liu, Huan. 2019b. Adaptive unsupervised feature selection on attributed networks. Pages 92–100 of: *Proceedings of the 25th ACM SIGKDD International Conference on Knowledge Discovery & Data Mining*.
- Li, Maosen, Chen, Siheng, Chen, Xu, Zhang, Ya, Wang, Yanfeng, and Tian, Qi. 2019c. Actional-Structural Graph Convolutional Networks for Skeleton-based Action Recognition. Pages 3595–3603 of: *Proceedings of the IEEE Conference on Computer Vision and Pattern Recognition*.
- Li, Qimai, Han, Zhichao, and Wu, Xiao-Ming. 2018b. Deeper Insights Into Graph Convolutional Networks for Semi-Supervised Learning. Pages 3538–3545 of: McIlraith, Sheila A., and Weinberger, Kilian Q. (eds), *Proceedings of the Thirty-Second AAAI Conference on Artificial Intelligence, (AAAI-18), the 30th Innovative Applications of Artificial Intelligence (IAAI-18), and the 8th AAAI Symposium on Educational Advances in Artificial Intelligence (EAAI-18), New Orleans, Louisiana, USA, February 2-7, 2018*. AAAI Press.
- Li, Ruoyu, Wang, Sheng, Zhu, Feiyun, and Huang, Junzhou. 2018c. Adaptive graph convolutional neural networks. In: *Thirty-Second AAAI Conference on Artificial Intelligence*.
- Li, Yaxin, Jin, Wei, Xu, Han, and Tang, Jiliang. 2020a. DeepRobust: A PyTorch Library for Adversarial Attacks and Defenses. *arXiv preprint arXiv:2005.06149*.
- Li, Ye, Sha, Chaofeng, Huang, Xin, and Zhang, Yanchun. 2018d. Community detection in attributed graphs: An embedding approach. In: *Thirty-Second AAAI Conference on Artificial Intelligence*.
- Li, Yu, Tian, Yuan, Zhang, Jiawei, and Chang, Yi. 2020b. Learning Signed Network Embedding via Graph Attention. In: *Proceedings of the Thirty-Fourth AAAI Conference on Artificial Intelligence*.
- Li, Yujia, Tarlow, Daniel, Brockschmidt, Marc, and Zemel, Richard. 2015. Gated graph sequence neural networks. *arXiv preprint arXiv:1511.05493*.
- Li, Zhuwen, Chen, Qifeng, and Koltun, Vladlen. 2018e. Combinatorial optimization with graph convolutional networks and guided tree search. Pages 539–548 of: *Advances in Neural Information Processing Systems*.
- Liang, Xiaodan, Shen, Xiaohui, Feng, Jiashi, Lin, Liang, and Yan, Shuicheng. 2016. Semantic object parsing with graph lstm. Pages 125–143 of: *European Conference on Computer Vision*. Springer.
- Liao, Renjie, Li, Yujia, Song, Yang, Wang, Shenlong, Hamilton, Will, Duvenaud,

- David K, Urtasun, Raquel, and Zemel, Richard. 2019. Efficient graph generation with graph recurrent attention networks. Pages 4255–4265 of: *Advances in Neural Information Processing Systems*.
- Liben-Nowell, David, and Kleinberg, Jon. 2007. The link-prediction problem for social networks. *Journal of the American society for information science and technology*, **58**(7), 1019–1031.
- Lin, Yankai, Liu, Zhiyuan, Sun, Maosong, Liu, Yang, and Zhu, Xuan. 2015. Learning entity and relation embeddings for knowledge graph completion. In: *Twenty-ninth AAAI conference on artificial intelligence*.
- Ling, Huan, Gao, Jun, Kar, Amlan, Chen, Wenzheng, and Fidler, Sanja. 2019. Fast interactive object annotation with curve-gcn. Pages 5257–5266 of: *Proceedings of the IEEE Conference on Computer Vision and Pattern Recognition*.
- Liu, Huan, and Motoda, Hiroshi. 2007. *Computational methods of feature selection*. CRC Press.
- Liu, Huan, and Motoda, Hiroshi. 2012. *Feature selection for knowledge discovery and data mining*. Vol. 454. Springer Science & Business Media.
- Liu, Ke, Sun, Xiangyan, Jia, Lei, Ma, Jun, Xing, Haoming, Wu, Junqiu, Gao, Hua, Sun, Yax, Boulnois, Florian, and Fan, Jie. 2018a. Chemi-net: a graph convolutional network for accurate drug property prediction. *arXiv preprint arXiv:1803.06236*.
- Liu, Qi, Nickel, Maximilian, and Kiela, Douwe. 2019a. Hyperbolic graph neural networks. Pages 8230–8241 of: *Advances in Neural Information Processing Systems*.
- Liu, Zhiwei, Dou, Yingdong, Yu, Philip S, Deng, Yutong, and Peng, Hao. 2020. Alleviating the Inconsistency Problem of Applying Graph Neural Network to Fraud Detection. *arXiv preprint arXiv:2005.00625*.
- Liu, Ziqi, Chen, Chaochao, Yang, Xinxing, Zhou, Jun, Li, Xiaolong, and Song, Le. 2018b. Heterogeneous graph neural networks for malicious account detection. Pages 2077–2085 of: *Proceedings of the 27th ACM International Conference on Information and Knowledge Management*.
- Liu, Ziqi, Chen, Chaochao, Li, Longfei, Zhou, Jun, Li, Xiaolong, Song, Le, and Qi, Yuan. 2019b. Geniepath: Graph neural networks with adaptive receptive paths. Pages 4424–4431 of: *Proceedings of the AAAI Conference on Artificial Intelligence*, vol. 33.
- Ma, Lingxiao, Yang, Zhi, Miao, Youshan, Xue, Jilong, Wu, Ming, Zhou, Lidong, and Dai, Yafei. 2018a. Towards efficient large-scale graph neural network computing. *arXiv preprint arXiv:1810.08403*.
- Ma, Lingxiao, Yang, Zhi, Miao, Youshan, Xue, Jilong, Wu, Ming, Zhou, Lidong, and Dai, Yafei. 2019a. Neugraph: parallel deep neural network computation on large graphs. Pages 443–458 of: *2019 {USENIX} Annual Technical Conference ({USENIX}{ATC} 19)*.
- Ma, Tengfei, Chen, Jie, and Xiao, Cao. 2018b. Constrained generation of semantically valid graphs via regularizing variational autoencoders. Pages 7113–7124 of: *Advances in Neural Information Processing Systems*.
- Ma, Tengfei, Xiao, Cao, Zhou, Jiayu, and Wang, Fei. 2018c. Drug similarity integration through attentive multi-view graph auto-encoders. *arXiv preprint arXiv:1804.10850*.

- Ma, Yao, Wang, Suhang, Ren, ZhaoChun, Yin, Dawei, and Tang, Jiliang. 2017. Preserving local and global information for network embedding. *arXiv preprint arXiv:1710.07266*.
- Ma, Yao, Ren, Zhaochun, Jiang, Ziheng, Tang, Jiliang, and Yin, Dawei. 2018d. Multi-dimensional network embedding with hierarchical structure. Pages 387–395 of: *Proceedings of the Eleventh ACM International Conference on Web Search and Data Mining*.
- Ma, Yao, Wang, Suhang, Aggarwal, Charu C., and Tang, Jiliang. 2019b. Graph Convolutional Networks with EigenPooling. Pages 723–731 of: Teredesai, Ankur, Kumar, Vipin, Li, Ying, Rosales, Rómer, Terzi, Evimaria, and Karypis, George (eds), *Proceedings of the 25th ACM SIGKDD International Conference on Knowledge Discovery & Data Mining, KDD 2019, Anchorage, AK, USA, August 4-8, 2019*. ACM.
- Ma, Yao, Wang, Suhang, Aggarwal, Chara C, Yin, Dawei, and Tang, Jiliang. 2019c. Multi-dimensional Graph Convolutional Networks. Pages 657–665 of: *Proceedings of the 2019 SIAM International Conference on Data Mining*. SIAM.
- Ma, Yao, Wang, Suhang, Derr, Tyler, Wu, Lingfei, and Tang, Jiliang. 2020a. *Attacking Graph Convolutional Networks via Rewiring*.
- Ma, Yao, Guo, Ziyi, Ren, Zhaocun, Tang, Jiliang, and Yin, Dawei. 2020b. Streaming graph neural networks. Pages 719–728 of: *Proceedings of the 43rd International ACM SIGIR Conference on Research and Development in Information Retrieval*.
- Maas, Andrew L, Hannun, Awni Y, and Ng, Andrew Y. 2013. Rectifier nonlinearities improve neural network acoustic models. In: *in ICML Workshop on Deep Learning for Audio, Speech and Language Processing*. Citeseer.
- Marcheggiani, Diego, and Titov, Ivan. 2017. Encoding Sentences with Graph Convolutional Networks for Semantic Role Labeling. Pages 1506–1515 of: *Proceedings of the 2017 Conference on Empirical Methods in Natural Language Processing*.
- Marcheggiani, Diego, Bastings, Joost, and Titov, Ivan. 2018. Exploiting Semantics in Neural Machine Translation with Graph Convolutional Networks. Pages 486–492 of: *Proceedings of the 2018 Conference of the North American Chapter of the Association for Computational Linguistics: Human Language Technologies, Volume 2 (Short Papers)*.
- McCulloch, Warren S, and Pitts, Walter. 1943. A logical calculus of the ideas immanent in nervous activity. *The bulletin of mathematical biophysics*, **5**(4), 115–133.
- Menon, Aditya Krishna, and Elkan, Charles. 2011. Link prediction via matrix factorization. Pages 437–452 of: *Joint european conference on machine learning and knowledge discovery in databases*. Springer.
- Mikolov, Tomas, Sutskever, Ilya, Chen, Kai, Corrado, Greg S, and Dean, Jeff. 2013. Distributed representations of words and phrases and their compositionality. Pages 3111–3119 of: *Advances in neural information processing systems*.
- Miller, George A. 1998. *WordNet: An electronic lexical database*. MIT press.
- Mishra, Pushkar, Del Tredici, Marco, Yannakoudakis, Helen, and Shutova, Ekaterina. 2019. Abusive Language Detection with Graph Convolutional Networks. Pages 2145–2150 of: *Proceedings of the 2019 Conference of the North American Chapter of the Association for Computational Linguistics: Human Language Technologies, Volume 1 (Long and Short Papers)*.

- Miwa, Makoto, and Bansal, Mohit. 2016. End-to-end relation extraction using lstms on sequences and tree structures. *arXiv preprint arXiv:1601.00770*.
- Monti, Federico, Bronstein, Michael, and Bresson, Xavier. 2017. Geometric matrix completion with recurrent multi-graph neural networks. Pages 3697–3707 of: *Advances in Neural Information Processing Systems*.
- Monti, Federico, Frasca, Fabrizio, Eynard, Davide, Mannion, Damon, and Bronstein, Michael M. 2019. Fake news detection on social media using geometric deep learning. *arXiv preprint arXiv:1902.06673*.
- Morin, Frederic, and Bengio, Yoshua. 2005. Hierarchical probabilistic neural network language model. Pages 246–252 of: *Aistats*, vol. 5. Citeseer.
- Morris, Christopher, Ritzert, Martin, Fey, Matthias, Hamilton, William L, Lenssen, Jan Eric, Rattan, Gaurav, and Grohe, Martin. 2019. Weisfeiler and leman go neural: Higher-order graph neural networks. Pages 4602–4609 of: *Proceedings of the AAAI Conference on Artificial Intelligence*, vol. 33.
- Nastase, Vivi, Mihalcea, Rada, and Radev, Dragomir R. 2015. A survey of graphs in natural language processing. *Natural Language Engineering*, **21**(5), 665–698.
- Nathani, Deepak, Chauhan, Jatin, Sharma, Charu, and Kaul, Manohar. 2019. Learning Attention-based Embeddings for Relation Prediction in Knowledge Graphs. Pages 4710–4723 of: *Proceedings of the 57th Annual Meeting of the Association for Computational Linguistics*.
- Neville, Jennifer, and Jensen, David. Iterative classification in relational data.
- Newman, Mark. 2018. *Networks: An Introduction*. Oxford university press.
- Newman, Mark EJ. 2006. Modularity and community structure in networks. *Proceedings of the national academy of sciences*, **103**(23), 8577–8582.
- Ng, Andrew, et al. Sparse autoencoder.
- Ng, Andrew Y, Jordan, Michael I, and Weiss, Yair. 2002. On spectral clustering: Analysis and an algorithm. Pages 849–856 of: *Advances in neural information processing systems*.
- Nguyen, Giang Hoang, Lee, John Boaz, Rossi, Ryan A, Ahmed, Nesreen K, Koh, Eunye, and Kim, Sungchul. 2018. Continuous-time dynamic network embeddings. Pages 969–976 of: *Companion Proceedings of the The Web Conference 2018*.
- Nguyen, Thin, Le, Hang, and Venkatesh, Svetha. 2019. GraphDTA: prediction of drug–target binding affinity using graph convolutional networks. *BioRxiv*, 684662.
- Nickel, Maximilian, Murphy, Kevin, Tresp, Volker, and Gabrilovich, Evgeniy. 2015. A review of relational machine learning for knowledge graphs. *Proceedings of the IEEE*, **104**(1), 11–33.
- Niepert, Mathias, Ahmed, Mohamed, and Kutzkov, Konstantin. 2016. Learning convolutional neural networks for graphs. Pages 2014–2023 of: *International conference on machine learning*.
- Norcliffe-Brown, Will, Vafeias, Stathis, and Parisot, Sarah. 2018. Learning conditioned graph structures for interpretable visual question answering. Pages 8334–8343 of: *Advances in Neural Information Processing Systems*.
- Nwankpa, Chigozie, Ijomah, Winifred, Gachagan, Anthony, and Marshall, Stephen. 2018. Activation functions: Comparison of trends in practice and research for deep learning. *arXiv preprint arXiv:1811.03378*.
- Olshausen, Bruno A, and Field, David J. 1997. Sparse coding with an overcomplete basis set: A strategy employed by V1? *Vision research*, **37**(23), 3311–3325.

- Oono, Kenta, and Suzuki, Taiji. 2020. Graph Neural Networks Exponentially Lose Expressive Power for Node Classification. In: *International Conference on Learning Representations*.
- Ou, Mingdong, Cui, Peng, Pei, Jian, Zhang, Ziwei, and Zhu, Wenwu. 2016. Asymmetric transitivity preserving graph embedding. Pages 1105–1114 of: *Proceedings of the 22nd ACM SIGKDD international conference on Knowledge discovery and data mining*.
- Owen, Art B. 2013. *Monte Carlo theory, methods and examples*.
- Pan, Shirui, Hu, Ruiqi, Long, Guodong, Jiang, Jing, Yao, Lina, and Zhang, Chengqi. 2018. Adversarially regularized graph autoencoder for graph embedding. *arXiv preprint arXiv:1802.04407*.
- Pareja, Aldo, Domeniconi, Giacomo, Chen, Jie, Ma, Tengfei, Suzumura, Toyotaro, Kanezashi, Hiroki, Kaler, Tim, and Leiserson, Charles E. 2019. Evolvegen: Evolving graph convolutional networks for dynamic graphs. *arXiv preprint arXiv:1902.10191*.
- Parisot, Sarah, Ktena, Sofia Ira, Ferrante, Enzo, Lee, Matthew, Guerrero, Ricardo, Glocker, Ben, and Rueckert, Daniel. 2018. Disease prediction using graph convolutional networks: Application to Autism Spectrum Disorder and Alzheimer's disease. *Medical image analysis*, **48**, 117–130.
- Park, Namyong, Kan, Andrey, Dong, Xin Luna, Zhao, Tong, and Faloutsos, Christos. 2019. Estimating node importance in knowledge graphs using graph neural networks. Pages 596–606 of: *Proceedings of the 25th ACM SIGKDD International Conference on Knowledge Discovery & Data Mining*.
- Paszke, Adam, Gross, Sam, Chintala, Soumith, Chanan, Gregory, Yang, Edward, DeVito, Zachary, Lin, Zeming, Desmaison, Alban, Antiga, Luca, and Lerer, Adam. 2017. Automatic differentiation in PyTorch.
- Peixoto, Tiago P. 2014. The graph-tool python library. *figshare*.
- Peng, Zhen, Dong, Yixiang, Luo, Minnan, Wu, Xiao-Ming, and Zheng, Qinghua. 2020. Self-Supervised Graph Representation Learning via Global Context Prediction. *arXiv preprint arXiv:2003.01604*.
- Perozzi, Bryan, Al-Rfou, Rami, and Skiena, Steven. 2014. Deepwalk: Online learning of social representations. Pages 701–710 of: *Proceedings of the 20th ACM SIGKDD international conference on Knowledge discovery and data mining*. ACM.
- Perraudin, Nathanaël, Paratte, Johan, Shuman, David, Martin, Lionel, Kalofolias, Vasilis, Vandergheynst, Pierre, and Hammond, David K. 2014. GSPBOX: A toolbox for signal processing on graphs. *arXiv preprint arXiv:1408.5781*.
- Perron, Oskar. 1907. Zur theorie der matrices. *Mathematische Annalen*, **64**(2), 248–263.
- Peters, Matthew E, Neumann, Mark, Iyyer, Mohit, Gardner, Matt, Clark, Christopher, Lee, Kenton, and Zettlemoyer, Luke. 2018. Deep contextualized word representations. *arXiv preprint arXiv:1802.05365*.
- Pillai, S Unnikrishna, Suel, Torsten, and Cha, Seunghun. 2005. The Perron-Frobenius theorem: some of its applications. *IEEE Signal Processing Magazine*, **22**(2), 62–75.

- Qi, Yanlin, Li, Qi, Karimian, Hamed, and Liu, Di. 2019. A hybrid model for spatiotemporal forecasting of PM_{2.5} based on graph convolutional neural network and long short-term memory. *Science of the Total Environment*, **664**, 1–10.
- Qiu, Jiezhong, Tang, Jian, Ma, Hao, Dong, Yuxiao, Wang, Kuansan, and Tang, Jie. 2018a. Deepinf: Social influence prediction with deep learning. Pages 2110–2119 of: *Proceedings of the 24th ACM SIGKDD International Conference on Knowledge Discovery & Data Mining*.
- Qiu, Jiezhong, Dong, Yuxiao, Ma, Hao, Li, Jian, Wang, Kuansan, and Tang, Jie. 2018b. Network embedding as matrix factorization: Unifying deepwalk, line, pte, and node2vec. Pages 459–467 of: *Proceedings of the Eleventh ACM International Conference on Web Search and Data Mining*. ACM.
- Radford, Alec, Wu, Jeff, Child, Rewon, Luan, David, Amodei, Dario, and Sutskever, Ilya. 2019. Language Models are Unsupervised Multitask Learners.
- Ren, Kui, Zheng, Tianhang, Qin, Zhan, and Liu, Xue. 2020. Adversarial attacks and defenses in deep learning. *Engineering*.
- Resnick, Paul, and Varian, Hal R. 1997. Recommender systems. *Communications of the ACM*, **40**(3), 56–58.
- Ribeiro, Leonardo FR, Saverese, Pedro HP, and Figueiredo, Daniel R. 2017. struc2vec: Learning node representations from structural identity. Pages 385–394 of: *Proceedings of the 23rd ACM SIGKDD International Conference on Knowledge Discovery and Data Mining*. ACM.
- Rong, Yu, Huang, Wenbing, Xu, Tingyang, and Huang, Junzhou. 2019. Dropedge: Towards deep graph convolutional networks on node classification. In: *International Conference on Learning Representations*.
- Rong, Yu, Huang, Wenbing, Xu, Tingyang, and Huang, Junzhou. 2020. DropEdge: Towards Deep Graph Convolutional Networks on Node Classification. In: *International Conference on Learning Representations*.
- Rosenblatt, Frank. 1958. The perceptron: a probabilistic model for information storage and organization in the brain. *Psychological review*, **65**(6), 386.
- Rossi, Ryan A., and Ahmed, Nesreen K. 2015. The Network Data Repository with Interactive Graph Analytics and Visualization. In: *Proceedings of the Twenty-Ninth AAAI Conference on Artificial Intelligence*.
- Rossi, Ryan A, Ahmed, Nesreen K, Koh, Eunye, Kim, Sungchul, Rao, Anup, and Yadkori, Yasin Abbasi. 2018. HONE: higher-order network embeddings. *arXiv preprint arXiv:1801.09303*.
- Roweis, Sam T, and Saul, Lawrence K. 2000. Nonlinear dimensionality reduction by locally linear embedding. *science*, **290**(5500), 2323–2326.
- Rumelhart, David E, Hinton, Geoffrey E, and Williams, Ronald J. 1986. Learning representations by back-propagating errors. *nature*, **323**(6088), 533–536.
- Rusek, Krzysztof, Suárez-Varela, José, Mestres, Albert, Barlet-Ros, Pere, and Cabellos-Aparicio, Albert. 2019. Unveiling the potential of Graph Neural Networks for network modeling and optimization in SDN. Pages 140–151 of: *Proceedings of the 2019 ACM Symposium on SDN Research*.
- Sahu, Sunil Kumar, Christopoulou, Fenia, Miwa, Makoto, and Ananiadou, Sophia. 2019. Inter-sentence Relation Extraction with Document-level Graph Convolutional Neural Network. *arXiv preprint arXiv:1906.04684*.

- Sailer, Lee Douglas. 1978. Structural equivalence: Meaning and definition, computation and application. *Social Networks*, **1**(1), 73–90.
- Salvador, Stan, and Chan, Philip. 2007. Toward accurate dynamic time warping in linear time and space. *Intelligent Data Analysis*, **11**(5), 561–580.
- Sankar, Aravind, Wu, Yanhong, Gou, Liang, Zhang, Wei, and Yang, Hao. 2018. Dynamic graph representation learning via self-attention networks. *arXiv preprint arXiv:1812.09430*.
- Scarselli, Franco, Yong, Sweah Liang, Gori, Marco, Hagenbuchner, Markus, Tsoi, Ah Chung, and Maggini, Marco. 2005. Graph neural networks for ranking web pages. Pages 666–672 of: *Proceedings of the 2005 IEEE/WIC/ACM International Conference on Web Intelligence*. IEEE Computer Society.
- Scarselli, Franco, Gori, Marco, Tsoi, Ah Chung, Hagenbuchner, Markus, and Monfardini, Gabriele. 2008. The graph neural network model. *IEEE Transactions on Neural Networks*, **20**(1), 61–80.
- Schlichtkrull, Michael, Kipf, Thomas N, Bloem, Peter, Van Den Berg, Rianne, Titov, Ivan, and Welling, Max. 2018. Modeling relational data with graph convolutional networks. Pages 593–607 of: *European Semantic Web Conference*. Springer.
- Seide, Frank, Li, Gang, and Yu, Dong. 2011. Conversational speech transcription using context-dependent deep neural networks. In: *Twelfth annual conference of the international speech communication association*.
- Sen, Prithviraj, Namata, Galileo, Bilgic, Mustafa, Getoor, Lise, Galligher, Brian, and Eliassi-Rad, Tina. 2008. Collective classification in network data. *AI magazine*, **29**(3), 93–93.
- Shang, Chao, Tang, Yun, Huang, Jing, Bi, Jinbo, He, Xiaodong, and Zhou, Bowen. 2019a. End-to-end structure-aware convolutional networks for knowledge base completion. Pages 3060–3067 of: *Proceedings of the AAAI Conference on Artificial Intelligence*, vol. 33.
- Shang, Junyuan, Xiao, Cao, Ma, Tengfei, Li, Hongyan, and Sun, Jimeng. 2019b. Gamenet: Graph augmented memory networks for recommending medication combination. Pages 1126–1133 of: *Proceedings of the AAAI Conference on Artificial Intelligence*, vol. 33.
- Shang, Junyuan, Ma, Tengfei, Xiao, Cao, and Sun, Jimeng. 2019c. Pre-training of graph augmented transformers for medication recommendation. *arXiv preprint arXiv:1906.00346*.
- Shchur, Oleksandr, and Günnemann, Stephan. 2019. Overlapping community detection with graph neural networks. *arXiv preprint arXiv:1909.12201*.
- Shi, Chuan, Hu, Binbin, Zhao, Wayne Xin, and Philip, S Yu. 2018a. Heterogeneous information network embedding for recommendation. *IEEE Transactions on Knowledge and Data Engineering*, **31**(2), 357–370.
- Shi, Jianbo, and Malik, Jitendra. 2000. Normalized cuts and image segmentation. *IEEE Transactions on pattern analysis and machine intelligence*, **22**(8), 888–905.
- Shi, Lei, Zhang, Yifan, Cheng, Jian, and Lu, Hanqing. 2019a. Skeleton-Based Action Recognition with Directed Graph Neural Networks. Pages 7912–7921 of: *Proceedings of the IEEE Conference on Computer Vision and Pattern Recognition*.
- Shi, Lei, Zhang, Yifan, Cheng, Jian, and Lu, Hanqing. 2019b. Two-stream adaptive graph convolutional networks for skeleton-based action recognition. Pages

- 12026–12035 of: *Proceedings of the IEEE Conference on Computer Vision and Pattern Recognition*.
- Shi, Yu, Han, Fangqiu, He, Xinwei, He, Xinran, Yang, Carl, Luo, Jie, and Han, Jiawei. 2018b. mvn2vec: Preservation and collaboration in multi-view network embedding. *arXiv preprint arXiv:1801.06597*.
- Shuman, David I, Narang, Sunil K, Frossard, Pascal, Ortega, Antonio, and Vandergheynst, Pierre. 2013. The emerging field of signal processing on graphs: Extending high-dimensional data analysis to networks and other irregular domains. *IEEE signal processing magazine*, **30**(3), 83–98.
- Si, Chenyang, Jing, Ya, Wang, Wei, Wang, Liang, and Tan, Tieniu. 2018. Skeleton-based action recognition with spatial reasoning and temporal stack learning. Pages 103–118 of: *Proceedings of the European Conference on Computer Vision (ECCV)*.
- Si, Chenyang, Chen, Wentao, Wang, Wei, Wang, Liang, and Tan, Tieniu. 2019. An attention enhanced graph convolutional lstm network for skeleton-based action recognition. Pages 1227–1236 of: *Proceedings of the IEEE Conference on Computer Vision and Pattern Recognition*.
- Simonovsky, Martin, and Komodakis, Nikos. 2017. Dynamic edge-conditioned filters in convolutional neural networks on graphs. Pages 3693–3702 of: *Proceedings of the IEEE conference on computer vision and pattern recognition*.
- Simonovsky, Martin, and Komodakis, Nikos. 2018. Graphvae: Towards generation of small graphs using variational autoencoders. Pages 412–422 of: *International Conference on Artificial Neural Networks*. Springer.
- Simonyan, Karen, and Zisserman, Andrew. 2014. Very deep convolutional networks for large-scale image recognition. *arXiv preprint arXiv:1409.1556*.
- Song, Linfeng, Peng, Xiaochang, Zhang, Yue, Wang, Zhiguo, and Gildea, Daniel. 2017. Amr-to-text generation with synchronous node replacement grammar. *arXiv preprint arXiv:1702.00500*.
- Song, Linfeng, Wang, Zhiguo, Yu, Mo, Zhang, Yue, Florian, Radu, and Gildea, Daniel. 2018a. Exploring graph-structured passage representation for multi-hop reading comprehension with graph neural networks. *arXiv preprint arXiv:1809.02040*.
- Song, Linfeng, Zhang, Yue, Wang, Zhiguo, and Gildea, Daniel. 2018b. A graph-to-sequence model for AMR-to-text generation. *arXiv preprint arXiv:1805.02473*.
- Song, Linfeng, Zhang, Yue, Wang, Zhiguo, and Gildea, Daniel. 2018c. N-ary relation extraction using graph state lstm. *arXiv preprint arXiv:1808.09101*.
- Srivastava, Nitish, Hinton, Geoffrey, Krizhevsky, Alex, Sutskever, Ilya, and Salakhutdinov, Ruslan. 2014. Dropout: a simple way to prevent neural networks from overfitting. *The journal of machine learning research*, **15**(1), 1929–1958.
- Sun, Changzhi, Gong, Yeyun, Wu, Yuanbin, Gong, Ming, Jiang, Daxin, Lan, Man, Sun, Shiliang, and Duan, Nan. 2019a. Joint type inference on entities and relations via graph convolutional networks. Pages 1361–1370 of: *Proceedings of the 57th Annual Meeting of the Association for Computational Linguistics*.
- Sun, Fan-Yun, Hoffmann, Jordan, and Tang, Jian. 2019b. InfoGraph: Unsupervised and Semi-supervised Graph-Level Representation Learning via Mutual Information Maximization. *arXiv preprint arXiv:1908.01000*.

- Sun, Ke, Lin, Zhouchen, and Zhu, Zhanxing. 2019c. Multi-Stage Self-Supervised Learning for Graph Convolutional Networks on Graphs with Few Labels. *arXiv preprint arXiv:1902.11038*.
- Sundararajan, Mukund, Taly, Ankur, and Yan, Qiqi. 2017. Axiomatic attribution for deep networks. Pages 3319–3328 of: *Proceedings of the 34th International Conference on Machine Learning-Volume 70*. JMLR. org.
- Sutskever, I, Vinyals, O, and Le, QV. 2014. Sequence to sequence learning with neural networks. *Advances in NIPS*.
- Sutton, Richard S, McAllester, David A, Singh, Satinder P, and Mansour, Yishay. 2000. Policy gradient methods for reinforcement learning with function approximation. Pages 1057–1063 of: *Advances in neural information processing systems*.
- Szegedy, Christian, Vanhoucke, Vincent, Ioffe, Sergey, Shlens, Jon, and Wojna, Zbigniew. 2016. Rethinking the inception architecture for computer vision. Pages 2818–2826 of: *Proceedings of the IEEE conference on computer vision and pattern recognition*.
- Tai, Kai Sheng, Socher, Richard, and Manning, Christopher D. 2015. Improved semantic representations from tree-structured long short-term memory networks. *arXiv preprint arXiv:1503.00075*.
- Tan, Pang-Ning, Steinbach, Michael, and Kumar, Vipin. 2016. *Introduction to data mining*. Pearson Education India.
- Tang, Jian, Qu, Meng, Wang, Mingzhe, Zhang, Ming, Yan, Jun, and Mei, Qiaozhu. 2015. Line: Large-scale information network embedding. Pages 1067–1077 of: *Proceedings of the 24th international conference on world wide web*. International World Wide Web Conferences Steering Committee.
- Tang, Jiliang, and Liu, Huan. 2012a. Feature selection with linked data in social media. Pages 118–128 of: *Proceedings of the 2012 SIAM International Conference on Data Mining*. SIAM.
- Tang, Jiliang, and Liu, Huan. 2012b. Unsupervised feature selection for linked social media data. Pages 904–912 of: *Proceedings of the 18th ACM SIGKDD international conference on Knowledge discovery and data mining*.
- Tang, Jiliang, Gao, Huiji, Hu, Xia, and Liu, Huan. 2013a. Exploiting homophily effect for trust prediction. Pages 53–62 of: *Proceedings of the sixth ACM international conference on Web search and data mining*.
- Tang, Jiliang, Hu, Xia, Gao, Huiji, and Liu, Huan. 2013b. Unsupervised feature selection for multi-view data in social media. Pages 270–278 of: *Proceedings of the 2013 SIAM International Conference on Data Mining*. SIAM.
- Tang, Jiliang, Alelyani, Salem, and Liu, Huan. 2014a. Feature selection for classification: A review. *Data classification: Algorithms and applications*, 37.
- Tang, Jiliang, Hu, Xia, and Liu, Huan. 2014b. Is distrust the negation of trust? the value of distrust in social media. Pages 148–157 of: *Proceedings of the 25th ACM conference on Hypertext and social media*.
- Tang, Jiliang, Aggarwal, Charu, and Liu, Huan. 2016a. Node classification in signed social networks. Pages 54–62 of: *Proceedings of the 2016 SIAM international conference on data mining*. SIAM.
- Tang, Jiliang, Chang, Yi, Aggarwal, Charu, and Liu, Huan. 2016b. A survey of signed network mining in social media. *ACM Computing Surveys (CSUR)*, **49**(3), 1–37.

- Tang, Lei, and Liu, Huan. 2009. Relational learning via latent social dimensions. Pages 817–826 of: *Proceedings of the 15th ACM SIGKDD international conference on Knowledge discovery and data mining*. ACM.
- Tang, Xianfeng, Li, Yandong, Sun, Yiwei, Yao, Huaxiu, Mitra, Prasenjit, and Wang, Suhang. 2019. Robust graph neural network against poisoning attacks via transfer learning. *arXiv preprint arXiv:1908.07558*.
- Tang, Xianfeng, Yao, Huaxiu, Sun, Yiwei, Wang, Yiqi, Tang, Jiliang, Aggarwal, Charu, Mitra, Prasenjit, and Wang, Suhang. 2020. Graph Convolutional Networks against Degree-Related Biases. *CIKM*.
- Tenenbaum, Joshua B, De Silva, Vin, and Langford, John C. 2000. A global geometric framework for nonlinear dimensionality reduction. *science*, **290**(5500), 2319–2323.
- Teney, Damien, Liu, Lingqiao, and van den Hengel, Anton. 2017. Graph-structured representations for visual question answering. Pages 1–9 of: *Proceedings of the IEEE Conference on Computer Vision and Pattern Recognition*.
- Trinajstić, Nenad. 2018. *Chemical graph theory*. Routledge.
- Tu, Ke, Cui, Peng, Wang, Xiao, Wang, Fei, and Zhu, Wenwu. 2018. Structural deep embedding for hyper-networks. In: *Thirty-Second AAAI Conference on Artificial Intelligence*.
- Tu, Ming, Wang, Guangtao, Huang, Jing, Tang, Yun, He, Xiaodong, and Zhou, Bowen. 2019. Multi-hop Reading Comprehension across Multiple Documents by Reasoning over Heterogeneous Graphs. Pages 2704–2713 of: *Proceedings of the 57th Annual Meeting of the Association for Computational Linguistics*.
- Vashishth, Shikhar, Sanyal, Soumya, Nitin, Vikram, and Talukdar, Partha. 2019. Composition-based multi-relational graph convolutional networks. *arXiv preprint arXiv:1911.03082*.
- Vaswani, Ashish, Shazeer, Noam, Parmar, Niki, Uszkoreit, Jakob, Jones, Llion, Gomez, Aidan N, Kaiser, Łukasz, and Polosukhin, Illia. 2017. Attention is all you need. Pages 5998–6008 of: *Advances in neural information processing systems*.
- Veličković, Petar, Cucurull, Guillem, Casanova, Arantxa, Romero, Adriana, Lio, Pietro, and Bengio, Yoshua. 2017. Graph attention networks. *arXiv preprint arXiv:1710.10903*.
- Velickovic, Petar, Fedus, William, Hamilton, William L, Liò, Pietro, Bengio, Yoshua, and Hjelm, R Devon. 2019. Deep Graph Infomax. In: *ICLR (Poster)*.
- Vinyals, Oriol, and Le, Quoc. 2015. A neural conversational model. *arXiv preprint arXiv:1506.05869*.
- Vosoughi, Soroush, Roy, Deb, and Aral, Sinan. 2018. The spread of true and false news online. *Science*, **359**(6380), 1146–1151.
- Wang, Daixin, Cui, Peng, and Zhu, Wenwu. 2016. Structural deep network embedding. Pages 1225–1234 of: *Proceedings of the 22nd ACM SIGKDD international conference on Knowledge discovery and data mining*. ACM.
- Wang, Fei, Li, Tao, Wang, Xin, Zhu, Shenghuo, and Ding, Chris. 2011. Community discovery using nonnegative matrix factorization. *Data Mining and Knowledge Discovery*, **22**(3), 493–521.
- Wang, Hao, Xu, Tong, Liu, Qi, Lian, Defu, Chen, Enhong, Du, Dongfang, Wu, Han,

- and Su, Wen. 2019a. MCNE: An End-to-End Framework for Learning Multiple Conditional Network Representations of Social Network. *arXiv preprint arXiv:1905.11013*.
- Wang, Hongwei, Wang, Jia, Wang, Jialin, Zhao, Miao, Zhang, Weinan, Zhang, Fuzheng, Xie, Xing, and Guo, Minyi. 2018a. Graphgan: Graph representation learning with generative adversarial nets. In: *Thirty-Second AAAI Conference on Artificial Intelligence*.
- Wang, Hongwei, Zhang, Fuzheng, Zhang, Mengdi, Leskovec, Jure, Zhao, Miao, Li, Wenjie, and Wang, Zhongyuan. 2019b. Knowledge-aware graph neural networks with label smoothness regularization for recommender systems. Pages 968–977 of: *Proceedings of the 25th ACM SIGKDD International Conference on Knowledge Discovery & Data Mining*.
- Wang, Hongwei, Zhao, Miao, Xie, Xing, Li, Wenjie, and Guo, Minyi. 2019c. Knowledge graph convolutional networks for recommender systems. Pages 3307–3313 of: *The World Wide Web Conference*. ACM.
- Wang, Jianyu, Wen, Rui, Wu, Chunming, Huang, Yu, and Xion, Jian. 2019d. Fdgars: Fraudster detection via graph convolutional networks in online app review system. Pages 310–316 of: *Companion Proceedings of The 2019 World Wide Web Conference*.
- Wang, Minjie, Yu, Lingfan, Zheng, Da, Gan, Quan, Gai, Yu, Ye, Zihao, Li, Mufei, Zhou, Jinjing, Huang, Qi, Ma, Chao, et al. 2019e. Deep graph library: Towards efficient and scalable deep learning on graphs. *arXiv preprint arXiv:1909.01315*.
- Wang, Peifeng, Han, Jialong, Li, Chenliang, and Pan, Rong. 2019f. Logic attention based neighborhood aggregation for inductive knowledge graph embedding. Pages 7152–7159 of: *Proceedings of the AAAI Conference on Artificial Intelligence*, vol. 33.
- Wang, Suhang, Aggarwal, Charu, Tang, Jiliang, and Liu, Huan. 2017a. Attributed signed network embedding. Pages 137–146 of: *Proceedings of the 2017 ACM on Conference on Information and Knowledge Management*.
- Wang, Suhang, Tang, Jiliang, Aggarwal, Charu, Chang, Yi, and Liu, Huan. 2017b. Signed network embedding in social media. Pages 327–335 of: *Proceedings of the 2017 SIAM international conference on data mining*. SIAM.
- Wang, Xiang, He, Xiangnan, Cao, Yixin, Liu, Meng, and Chua, Tat-Seng. 2019g. KGAT: Knowledge Graph Attention Network for Recommendation. *arXiv preprint arXiv:1905.07854*.
- Wang, Xiang, He, Xiangnan, Wang, Meng, Feng, Fuli, and Chua, Tat-Seng. 2019h. Neural graph collaborative filtering. Pages 165–174 of: *Proceedings of the 42nd international ACM SIGIR conference on Research and development in Information Retrieval*.
- Wang, Xiao, Cui, Peng, Wang, Jing, Pei, Jian, Zhu, Wenwu, and Yang, Shiqiang. 2017c. Community preserving network embedding. In: *Thirty-first AAAI conference on artificial intelligence*.
- Wang, Xiao, Ji, Houye, Shi, Chuan, Wang, Bai, Ye, Yanfang, Cui, Peng, and Yu, Philip S. 2019i. Heterogeneous graph attention network. Pages 2022–2032 of: *The World Wide Web Conference*.
- Wang, Xiaolong, Ye, Yufei, and Gupta, Abhinav. 2018b. Zero-shot recognition via

- semantic embeddings and knowledge graphs. Pages 6857–6866 of: *Proceedings of the IEEE Conference on Computer Vision and Pattern Recognition*.
- Wang, Xiaoyang, Ma, Yao, Wang, Yiqi, Jin, Wei, Wang, Xin, Tang, Jiliang, Jia, Caiyan, and Yu, Jian. 2020a. Traffic Flow Prediction via Spatial Temporal Graph Neural Network. Pages 1082–1092 of: *Proceedings of The Web Conference 2020*.
- Wang, Xuhong, Du, Ying, Cui, Ping, and Yang, Yupu. 2020b. OCGNN: One-class Classification with Graph Neural Networks. *arXiv preprint arXiv:2002.09594*.
- Wang, Yaping, Jiao, Pengfei, Wang, Wenjun, Lu, Chunyu, Liu, Hongtao, and Wang, Bo. 2019j. Bipartite network embedding via effective integration of explicit and implicit relations. Pages 435–451 of: *International Conference on Database Systems for Advanced Applications*. Springer.
- Wang, Yue, Sun, Yongbin, Liu, Ziwei, Sarma, Sanjay E, Bronstein, Michael M, and Solomon, Justin M. 2019k. Dynamic graph cnn for learning on point clouds. *ACM Transactions on Graphics (TOG)*, **38**(5), 1–12.
- Wang, Zhichun, Lv, Qingsong, Lan, Xiaohan, and Zhang, Yu. 2018c. Cross-lingual knowledge graph alignment via graph convolutional networks. Pages 349–357 of: *Proceedings of the 2018 Conference on Empirical Methods in Natural Language Processing*.
- Watkins, Christopher JCH, and Dayan, Peter. 1992. Q-learning. *Machine learning*, **8**(3-4), 279–292.
- Weber, Mark, Domeniconi, Giacomo, Chen, Jie, Weidele, Daniel Karl I, Bellei, Claudio, Robinson, Tom, and Leiserson, Charles E. 2019. Anti-money laundering in bitcoin: Experimenting with graph convolutional networks for financial forensics. *arXiv preprint arXiv:1908.02591*.
- Wei, Xiaokai, Xie, Sihong, and Yu, Philip S. 2015. Efficient partial order preserving unsupervised feature selection on networks. Pages 82–90 of: *Proceedings of the 2015 SIAM International Conference on Data Mining*. SIAM.
- Wei, Xiaokai, Cao, Bokai, and Philip, S Yu. 2016. Unsupervised feature selection on networks: a generative view. In: *Thirtieth AAAI Conference on Artificial Intelligence*.
- Weisfeiler, B, and Leman, A. The reduction of a graph to canonical form and the algebra which appears therein.
- Welbl, Johannes, Stenetorp, Pontus, and Riedel, Sebastian. 2018. Constructing datasets for multi-hop reading comprehension across documents. *Transactions of the Association for Computational Linguistics*, **6**, 287–302.
- Wen, Yu-Hui, Gao, Lin, Fu, Hongbo, Zhang, Fang-Lue, and Xia, Shihong. 2019. Graph CNNs with motif and variable temporal block for skeleton-based action recognition. Pages 8989–8996 of: *Proceedings of the AAAI Conference on Artificial Intelligence*, vol. 33.
- Werbos, Paul John. 1994. *The roots of backpropagation: from ordered derivatives to neural networks and political forecasting*. Vol. 1. John Wiley & Sons.
- Werling, Donna M, and Geschwind, Daniel H. 2013. Sex differences in autism spectrum disorders. *Current opinion in neurology*, **26**(2), 146.
- Widder, David Vernon, and Hirschman, Isidore Isaac. 2015. *Convolution Transform*. Vol. 2153. Princeton University Press.

- Wu, Huijun, Wang, Chen, Tyshetskiy, Yuriy, Docherty, Andrew, Lu, Kai, and Zhu, Liming. 2019. Adversarial Examples for Graph Data: Deep Insights into Attack and Defense. Pages 4816–4823 of: Kraus, Sarit (ed), *Proceedings of the Twenty-Eighth International Joint Conference on Artificial Intelligence, IJCAI 2019, Macao, China, August 10-16, 2019*. ijcai.org.
- Wu, Zonghan, Pan, Shirui, Chen, Fengwen, Long, Guodong, Zhang, Chengqi, and Philip, S Yu. 2020. A comprehensive survey on graph neural networks. *IEEE Transactions on Neural Networks and Learning Systems*.
- Xu, Bingbing, Shen, Huawei, Cao, Qi, Qiu, Yunqi, and Cheng, Xueqi. 2019a. Graph Wavelet Neural Network. *arXiv preprint arXiv:1904.07785*.
- Xu, Han, Ma, Yao, Liu, Haochen, Deb, Debayan, Liu, Hui, Tang, Jiliang, and Jain, Anil. 2019b. Adversarial attacks and defenses in images, graphs and text: A review. *arXiv preprint arXiv:1909.08072*.
- Xu, Jian. 2017. Representing Big Data as Networks: New Methods and Insights. *arXiv preprint arXiv:1712.09648*.
- Xu, Kaidi, Chen, Hongge, Liu, Sijia, Chen, Pin-Yu, Weng, Tsui-Wei, Hong, Mingyi, and Lin, Xue. 2019c. Topology Attack and Defense for Graph Neural Networks: An Optimization Perspective. Pages 3961–3967 of: Kraus, Sarit (ed), *Proceedings of the Twenty-Eighth International Joint Conference on Artificial Intelligence, IJCAI 2019, Macao, China, August 10-16, 2019*. ijcai.org.
- Xu, Keyulu, Li, Chengtao, Tian, Yonglong, Sonobe, Tomohiro, Kawarabayashi, Ken-ichi, and Jegelka, Stefanie. 2018a. Representation Learning on Graphs with Jumping Knowledge Networks. Pages 5449–5458 of: Dy, Jennifer G., and Krause, Andreas (eds), *Proceedings of the 35th International Conference on Machine Learning, ICML 2018, Stockholmsmässan, Stockholm, Sweden, July 10-15, 2018*. Proceedings of Machine Learning Research, vol. 80. PMLR.
- Xu, Keyulu, Hu, Weihua, Leskovec, Jure, and Jegelka, Stefanie. 2019d. How Powerful are Graph Neural Networks? In: *7th International Conference on Learning Representations, ICLR 2019, New Orleans, LA, USA, May 6-9, 2019*. OpenReview.net.
- Xu, Kun, Wu, Lingfei, Wang, Zhiguo, Feng, Yansong, Witbrock, Michael, and Sheinin, Vadim. 2018b. Graph2seq: Graph to sequence learning with attention-based neural networks. *arXiv preprint arXiv:1804.00823*.
- Xu, Kun, Wang, Liwei, Yu, Mo, Feng, Yansong, Song, Yan, Wang, Zhiguo, and Yu, Dong. 2019e. Cross-lingual Knowledge Graph Alignment via Graph Matching Neural Network. *arXiv preprint arXiv:1905.11605*.
- Xuan, Ping, Pan, Shuxiang, Zhang, Tiangang, Liu, Yong, and Sun, Hao. 2019. Graph convolutional network and convolutional neural network based method for predicting lncRNA-disease associations. *Cells*, 8(9), 1012.
- Yadati, Naganand, Nimishakavi, Madhav, Yadav, Prateek, Nitin, Vikram, Louis, Anand, and Talukdar, Partha. 2019. HyperGCN: A New Method For Training Graph Convolutional Networks on Hypergraphs. Pages 1509–1520 of: *Advances in Neural Information Processing Systems*.
- Yan, Sijie, Xiong, Yuanjun, and Lin, Dahua. 2018. Spatial temporal graph convolutional networks for skeleton-based action recognition. In: *Thirty-Second AAAI Conference on Artificial Intelligence*.

- Yanardag, Pinar, and Vishwanathan, SVN. 2015. Deep graph kernels. Pages 1365–1374 of: *Proceedings of the 21th ACM SIGKDD International Conference on Knowledge Discovery and Data Mining*.
- Yang, Bishan, Yih, Wen-tau, He, Xiaodong, Gao, Jianfeng, and Deng, Li. 2014. Learning multi-relational semantics using neural-embedding models. *arXiv preprint arXiv:1411.4072*.
- Yang, Jaewon, and Leskovec, Jure. 2015. Defining and evaluating network communities based on ground-truth. *Knowledge and Information Systems*, **42**(1), 181–213.
- Yang, Xu, Tang, Kaihua, Zhang, Hanwang, and Cai, Jianfei. 2019. Auto-encoding scene graphs for image captioning. Pages 10685–10694 of: *Proceedings of the IEEE Conference on Computer Vision and Pattern Recognition*.
- Yao, Liang, Mao, Chengsheng, and Luo, Yuan. 2019. Graph convolutional networks for text classification. Pages 7370–7377 of: *Proceedings of the AAAI Conference on Artificial Intelligence*, vol. 33.
- Ying, Rex, He, Ruining, Chen, Kaifeng, Eksombatchai, Pong, Hamilton, William L, and Leskovec, Jure. 2018a. Graph convolutional neural networks for web-scale recommender systems. Pages 974–983 of: *Proceedings of the 24th ACM SIGKDD International Conference on Knowledge Discovery & Data Mining*.
- Ying, Rex, He, Ruining, Chen, Kaifeng, Eksombatchai, Pong, Hamilton, William L, and Leskovec, Jure. 2018b. Graph convolutional neural networks for web-scale recommender systems. Pages 974–983 of: *Proceedings of the 24th ACM SIGKDD International Conference on Knowledge Discovery & Data Mining*. ACM.
- Ying, Zhitao, You, Jiaxuan, Morris, Christopher, Ren, Xiang, Hamilton, Will, and Leskovec, Jure. 2018c. Hierarchical graph representation learning with differentiable pooling. Pages 4800–4810 of: *Advances in Neural Information Processing Systems*.
- Ying, Zhitao, Bourgeois, Dylan, You, Jiaxuan, Zitnik, Marinka, and Leskovec, Jure. 2019. Gnnexplainer: Generating explanations for graph neural networks. Pages 9244–9255 of: *Advances in neural information processing systems*.
- You, Jiaxuan, Liu, Bowen, Ying, Zhitao, Pande, Vijay, and Leskovec, Jure. 2018a. Graph convolutional policy network for goal-directed molecular graph generation. Pages 6410–6421 of: *Advances in neural information processing systems*.
- You, Jiaxuan, Ying, Rex, Ren, Xiang, Hamilton, William L, and Leskovec, Jure. 2018b. Graphrnn: Generating realistic graphs with deep auto-regressive models. *arXiv preprint arXiv:1802.08773*.
- You, Yuning, Chen, Tianlong, Wang, Zhangyang, and Shen, Yang. 2020. When Does Self-Supervision Help Graph Convolutional Networks? *arXiv preprint arXiv:2006.09136*.
- Yu, Bing, Yin, Haoteng, and Zhu, Zhanxing. 2017. Spatio-temporal graph convolutional networks: A deep learning framework for traffic forecasting. *arXiv preprint arXiv:1709.04875*.
- Yu, Dong, and Deng, Li. 2016. *AUTOMATIC SPEECH RECOGNITION*. Springer.
- Yuan, Hao, and Ji, Shuiwang. 2019. StructPool: Structured graph pooling via conditional random fields. In: *International Conference on Learning Representations*.
- Yuan, Hao, Tang, Jiliang, Hu, Xia, and Ji, Shuiwang. 2020. XGNN: Towards Model-Level Explanations of Graph Neural Networks. *arXiv preprint arXiv:2006.02587*.

- Yuan, Shuhan, Wu, Xintao, and Xiang, Yang. 2017. SNE: signed network embedding. Pages 183–195 of: *Pacific-Asia conference on knowledge discovery and data mining*. Springer.
- Yuan, Xiaoyong, He, Pan, Zhu, Qile, and Li, Xiaolin. 2019. Adversarial examples: Attacks and defenses for deep learning. *IEEE transactions on neural networks and learning systems*, **30**(9), 2805–2824.
- Zeiler, Matthew D. 2012. ADADELTA: an adaptive learning rate method. *arXiv preprint arXiv:1212.5701*.
- Zeng, Hanqing, Zhou, Hongkuan, Srivastava, Ajitesh, Kannan, Rajgopal, and Prasanna, Viktor. 2019. Graphsaint: Graph sampling based inductive learning method. *arXiv preprint arXiv:1907.04931*.
- Zhang, Chuxu, Song, Dongjin, Huang, Chao, Swami, Ananthram, and Chawla, Nitesh V. 2019a. Heterogeneous graph neural network. Pages 793–803 of: *Proceedings of the 25th ACM SIGKDD International Conference on Knowledge Discovery & Data Mining*.
- Zhang, Fanjin, Liu, Xiao, Tang, Jie, Dong, Yuxiao, Yao, Peiran, Zhang, Jie, Gu, Xiaotao, Wang, Yan, Shao, Bin, Li, Rui, et al. 2019b. Oag: Toward linking large-scale heterogeneous entity graphs. Pages 2585–2595 of: *Proceedings of the 25th ACM SIGKDD International Conference on Knowledge Discovery & Data Mining*.
- Zhang, Guo, He, Hao, and Katabi, Dina. 2019c. Circuit-GNN: Graph neural networks for distributed circuit design. Pages 7364–7373 of: *International Conference on Machine Learning*.
- Zhang, Jiani, Shi, Xingjian, Xie, Junyuan, Ma, Hao, King, Irwin, and Yeung, Dit-Yan. 2018a. Gaan: Gated attention networks for learning on large and spatiotemporal graphs. *arXiv preprint arXiv:1803.07294*.
- Zhang, Ningyu, Deng, Shumin, Sun, Zhanlin, Wang, Guanying, Chen, Xi, Zhang, Wei, and Chen, Huajun. 2019d. Long-tail Relation Extraction via Knowledge Graph Embeddings and Graph Convolution Networks. *arXiv preprint arXiv:1903.01306*.
- Zhang, Wei Emma, Sheng, Quan Z, Alhazmi, Ahoud, and Li, Chenliang. 2020. Adversarial attacks on deep-learning models in natural language processing: A survey. *ACM Transactions on Intelligent Systems and Technology (TIST)*, **11**(3), 1–41.
- Zhang, Yizhou, Xiong, Yun, Kong, Xiangnan, Li, Shanshan, Mi, Jinhong, and Zhu, Yangyong. 2018b. Deep collective classification in heterogeneous information networks. Pages 399–408 of: *Proceedings of the 2018 World Wide Web Conference*.
- Zhang, Yuhao, Qi, Peng, and Manning, Christopher D. 2018c. Graph Convolution over Pruned Dependency Trees Improves Relation Extraction. Pages 2205–2215 of: *Proceedings of the 2018 Conference on Empirical Methods in Natural Language Processing*.
- Zhao, Lingxiao, and Akoglu, Leman. 2019. PairNorm: Tackling Oversmoothing in GNNs. *arXiv preprint arXiv:1909.12223*.
- Zhou, Jie, Cui, Ganqu, Zhang, Zhengyan, Yang, Cheng, Liu, Zhiyuan, Wang, Lifeng, Li, Changcheng, and Sun, Maosong. 2018a. Graph neural networks: A review of methods and applications. *arXiv preprint arXiv:1812.08434*.
- Zhou, Lekui, Yang, Yang, Ren, Xiang, Wu, Fei, and Zhuang, Yueting. 2018b. Dynamic network embedding by modeling triadic closure process. In: *Thirty-Second AAAI Conference on Artificial Intelligence*.

- Zhou, Yaqin, Liu, Shangqing, Siow, Jingkai, Du, Xiaoning, and Liu, Yang. 2019. Devign: Effective vulnerability identification by learning comprehensive program semantics via graph neural networks. Pages 10197–10207 of: *Advances in Neural Information Processing Systems*.
- Zhu, Dingyuan, Zhang, Ziwei, Cui, Peng, and Zhu, Wenwu. 2019a. Robust graph convolutional networks against adversarial attacks. Pages 1399–1407 of: *Proceedings of the 25th ACM SIGKDD International Conference on Knowledge Discovery & Data Mining*.
- Zhu, Hao, Lin, Yankai, Liu, Zhiyuan, Fu, Jie, Chua, Tat-seng, and Sun, Maosong. 2019b. Graph Neural Networks with Generated Parameters for Relation Extraction. *arXiv preprint arXiv:1902.00756*.
- Zhu, Rong, Zhao, Kun, Yang, Hongxia, Lin, Wei, Zhou, Chang, Ai, Baole, Li, Yong, and Zhou, Jingren. 2019c. Aligraph: A comprehensive graph neural network platform. *arXiv preprint arXiv:1902.08730*.
- Zhu, Shenghuo, Yu, Kai, Chi, Yun, and Gong, Yihong. 2007. Combining content and link for classification using matrix factorization. Pages 487–494 of: *Proceedings of the 30th annual international ACM SIGIR conference on Research and development in information retrieval*.
- Zhu, Xiaojin, Ghahramani, Zoubin, and Lafferty, John D. 2003. Semi-supervised learning using gaussian fields and harmonic functions. Pages 912–919 of: *Proceedings of the 20th International conference on Machine learning (ICML-03)*.
- Zitnik, Marinka, Agrawal, Monica, and Leskovec, Jure. 2018. Modeling polypharmacy side effects with graph convolutional networks. *Bioinformatics*, **34**(13), i457–i466.
- Zügner, Daniel, and Günnemann, Stephan. 2019. Adversarial attacks on graph neural networks via meta learning. *arXiv preprint arXiv:1902.08412*.
- Zügner, Daniel, Akbarnejad, Amir, and Günnemann, Stephan. 2018. Adversarial attacks on neural networks for graph data. Pages 2847–2856 of: *Proceedings of the 24th ACM SIGKDD International Conference on Knowledge Discovery & Data Mining*.

Index

- ABIDE database, 263
- abstract meaning representation, 207
- abstract syntax tree, 284
- across-dimension neighbor, 179
- across-dimension representation, 181
- activation functions, 47
- adjacency matrix, 185, 224, 263
- adjacent matrix, 18
- adversarial attack, 138
- air pollution, 246
- air quality, 246
- air quality forecasting, 246
- amino acid, 254
- amino acid residues, 256
- AMR, 207
- anti-money laundering, 251
- artificial neural networks, 43
- ASD, 263
- AST, 284
- attention mechanism, 211, 239
- attribute mask, 273
- attribute masking, 275
- autism spectrum disorder, 263
- autoencoder, 63–67, 189, 195
 - decoder, 65
 - encoder, 64
 - regularized autoencoder, 66
 - undercomplete autoencoder, 65
- auxiliary task, 272
- backpropagation, 68–70
- balance theory, 182
- balanced representation, 183
- batch normalization, 71
- BERT, 271
- betweenness centrality, 25
- Bi-directional LSTM, 208
- Bi-LSTM, 208, 211
- binary classification, 238, 256
- binary graph classification, 249
- bio-chemistry, 252
- bipartite graph, 34
- bipartite graph embedding, 96–97
- bipartite graph neural network, 178
- bouncing balls, 285
- cell memory, 192
- centrality, 23–26
 - betweenness centrality, 25
 - degree centrality, 23
 - eigenvector centrality, 24
 - Katz centrality, 25
- centrality ranking, 272
- CFG, 284
- charged particles, 285
- chemical bonds, 258
- CNN, 44, 52–59
- collaborative filtering, 240
- combinatorial optimization, 281
- complex graph, 33–38, 94, 176–187
 - bipartite, 34, 96–97, 178
 - dynamic, 37, 104–105, 185
 - discrete, 38
 - heterogeneous, 33, 94–96, 176
 - hyper, 37, 102–104, 184
 - multi-dimensional, 34, 97–99, 179
 - signed, 36, 99–102, 181
- computational phenotyping, 264
- computer vision, 222–235
- connected component, 22, 28
- connected graph, 22
- connectivity, 21
- Context Prediction, 274
- ContextLabel, 274

- control flow graph, 284
- control variate, 168
- convolution operation, 52–57
- convolutional layer, 52–57
- convolutional neural network, 44, 52–59
 - convolution operation, 52
 - equivariant representation, 55
 - filter, 53
 - kernel, 53
 - parameter sharing, 55
 - sparse connection, 54
 - convolutional layer, 52
 - channel, 56
 - stride, 57
 - pooling layer, 58
 - average, 58
 - max, 58
- CorrectedLabel, 274
- cyber attacker, 247
- cybersecurity, 247
- cybersecurity data mining, 247
- data flow graph, 284
- data mining, 236–251
- DDI, 258
- decoder, 189, 195, 211
- deep learning, 1, 43–71
- deep neural networks, 43
- deep Q-learning, 149
- deepwalk, 77–84
- degree, 19
- degree centrality, 23
- degree matrix, 26, 27
- dependency relation, 210
- DFG, 284
- diameter, 23, 164
- discrete dynamic graph, 38
- discriminator, 201, 202
- disease association prediction, 264
- disease prediction, 262
- DisMult factorization, 220
- Distance2Clusters, 273
- Distance2Labeled, 273
- distributed circuit design, 286
- dropedge, 270
- dropout, 71
- drug, 252
- drug development, 252
- drug discovery, 252
- drug re-purposing, 253, 256
- drug similarity integration, 258
- drug-drug interaction, 258, 260
 - drug-drug interaction prediction, 258
 - drug-protein interaction, 260
 - drug-protein pair, 258
 - drug-target binding affinity prediction, 252, 256
 - drug-target interaction, 256
 - drug-target interaction prediction, 257
- DTI, 256
- dynamic graph, 37
- dynamic graph embedding, 104–105
- dynamic graph neural network, 185
- dynamical system, 285
- e-commerce, 247
- e-finance, 247
- ECC-filter, 197
- edge, 18
- edge mask, 272
- ego-network, 237
- eigen-decomposition, 269
- eigenvector centrality, 24
- ELU, 48
- encoder, 195, 211
- entity graph, 214
 - COMPLEMENT edge, 215
 - COREF edge, 215
 - DOC-BASED edge, 215
 - MATCH edge, 215
- entity-GCN, 213, 214
- EvolveGCN, 185
- explainable graph neural network, 280
- expressive piano performance, 286
- expressiveness, 275
- fake news, 249
- fake news detection, 249
- fast gradient sign method, 143
- feature engineering, 8
- feature learning, 8
- feature selection, 10
- feedforward networks, 44–51
- few-shot image classification, 231
- FGSM, 143
- finite Markov decision process, 149, 150
- fraud detection, 251
- frequency component, 113
- functional MRI, 263
- GAN, 199
- GAT-Filter, 221
- gated global pooling, 197, 202
- gated recurrent unit, 63
 - update gate, 63

- Gaussian distribution, 195
- Gaussian kernel, 225, 263
- GCN-Filter, 132, 162, 165, 184–186, 190, 218, 228, 256, 259, 268, 269
- generative adversarial network, 199
- generative model, 195
- generator, 200, 202
- GGNN-Filter, 225
- GNN, 107–136
- GNN-Filter, 246
- GPT-2, 271
- Graclus, 173
- gradient descent, 67, 162
- graph, 1, 17, 188, 191
- graph adversarial attack, 138–151
 - black-box attack, 141, 148–151
 - rewatt, 150
 - RL-S2V, 148
 - evasion attack, 140
 - gray-box attack, 140, 144–148
 - poisoning attack, 140
 - targeted attack, 140
 - untargeted attack, 140
 - white-box attack, 140–144
 - integrated gradient guided attack, 143
 - metattack), 146
 - netattack), 144
 - PGD topology attack, 141
- graph adversarial defense, 151–160
- graph adversarial training, 152–154
- graph attention, 155–159
 - PA-GNN, 157
 - RGCN, 155
- graph purification, 154–155
- graph structural learning, 159
 - Pro-GNN, 159
- graph classification, 41, 136
- graph embedding, 75–105
 - community structure, 91–93
 - information extractor, 76
 - mapping function, 76
 - node co-occurrence, 77
 - node status, 89–91
 - structural role, 86–89
- graph filter, 107, 112–128, 183, 185, 218
 - spatial-based graph filter, 122
 - ECC-Filter, 126
 - GAT-Filter, 124
 - GGNN-Filter, 126
 - GraphSAGE-Filter, 123
 - Mo-Filter, 127
 - MPNN-Filter, 128
 - spectral-based graph filter, 112–122
 - Cheby-Filter, 118–120
 - GCN-Filter, 120
- graph filtering, 107, 270
- graph filtering operation, 246
- graph Fourier basis, 32
- graph Fourier coefficient, 32, 113
- Graph Fourier Transform, 30
- graph Fourier transform, 113
- graph generation, 196, 201
- graph isomorphism, 276
- graph neural network, 138, 190, 207, 227, 267, 282
 - graph filter, 107
 - graph filtering, 107
 - graph pooling, 108
 - robust, 138–161
 - scalable, 162–174
- graph neural networks, 107–136
- graph pooling, 108, 128–134
 - flat graph pooling, 129
 - average pooling, 129
 - gated global pooling, 129
 - max pooling, 129
 - hierarchical graph pooling, 130–134
 - downsampling based pooling, 130–132
 - supernode based pooling, 132–134
- graph property prediction, 275
- graph signal, 29–32, 113
- graph signal processing, 29
- graph spectral filtering, 112
- graph to sequence learning, 207, 216
 - graph classification, 41
- Graph-LSTM, 191
- GraphSAGE-Filter, 167
- GRU, 63, 186, 258
- Hadamard product, 190
- healthcare, 252
- heterogeneous graph, 33
- heterogeneous graph embedding, 94–96
- heterogeneous graph neural network, 176
- hidden state, 193
- hierarchical softmax, 81
- human action recognition, 227
- human body skeleton, 227
- hyperbolic geometry, 280
- hyperbolic space, 280
- hyperbolic tangent, 49
- hyperedge, 37, 184

- hypergraph, 37
- hypergraph embedding, 102–104
- hypergraph neural network, 184
- image, 224
- image captioning, 235
- image classification, 229
- importance sampling, 170
- Inception, 271
- incidence matrix, 184
- inference model, 195
- injective operation, 278
- interacting system, 285
- interaction network, 285
- inverse graph Fourier transform, 113
- Jaccard similarity, 154
- joint training, 272, 274
- Katz centrality, 25
- knowledge graph, 243
- knowledge graph, 207, 218, 230, 232
- knowledge graph completion, 220
- Laplacian matrix, 26–29, 113
 - eigenvalue, 28
 - eigenvector, 28, 113
 - normalized, 27, 269
- layer-wise sampling, 168–172
- LeakyReLU, 48
- ligand protein, 256
- LINE, 85
- linear classifier, 230
- linear transformation, 225
- link prediction, 40
- logistic regression, 230
- long short-term memory, 61–63
 - cell state, 61
 - forget gate, 62
 - hidden state, 61
 - input gate, 62
 - output gate, 62
- LSTM, 61, 186, 192, 208, 247, 258
- machine reading comprehension, 213
- malicious account, 247
- malicious account detection, 248
- matrix factorization, 243
- MAXCUT, 282
- maximal independent set, 282
- maximum cut, 282
- McCulloch-Pitts Neuron, 43
- medical images, 262
- medication recommendation, 264
- Mento-Carlo sampling, 166
- meta-gradient, 147
- meta-optimization, 158
- meta-path, 95, 177
 - meta-path schema, 95
- meta-path based neighbors, 177
- meta-path schema, 177
- Metis, 173, 273
- minimum vertex cover, 281
- minmax game, 199
- MIS, 282
- model-level explanation, 280
- molecular fingerprint, 253
- molecular graph generation, 252
- molecular property prediction, 252
- molecular representation, 254
- molecular representation learning, 252
- molecule, 252
- MPNN-Filter, 254
- multi-dimensional graph, 34
- multi-dimensional graph embedding, 97–99
- multi-dimensional graph neural network, 179
- multi-hop QA, 213
- multi-label image classification, 232
- multi-modal graph, 260
- multi-relational link prediction, 260
- multivariate Gaussian distribution, 155
- MVC, 281
- N-body, 285
- natural code sequence, 284
- natural language generation, 216
- natural language processing, 207–221
- NCS, 284
- negative edge, 182
- negative sampling, 83
- neighbor, 20, 164
 - balanced, 182
 - temporal, 228
 - unbalanced, 182
- neighborhood expansion, 164
- neighborhood explosion, 164, 165, 167
- neural machine translation, 207, 211
- NLG, 216
- NLP, 207–221
- node, 18
- node annotation, 282
- node classification, 39, 135, 282
- node property, 272
- node representation, 12, 224
- node representation learning, 189, 195, 200
- node-focused task, 39, 109, 271
 - link prediction, 40

- node classification, 39
- node-wise sampling, 166–168
- node2vec, 84
- non-isomorphic graph, 278
- online social media, 249
- over smoothing, 268
- pairnorm, 270
- pairwise distance, 272
- PairwiseAttSim, 273
- parse tree, 207
- path, 21
 - balanced, 182
 - unbalanced, 182
- perceptron, 43
- phenotypic measure, 263
- point clouds, 233
- polypharmacy, 260
- polypharmacy side effect, 260
- polypharmacy side effect prediction, 259
- pooling layer, 58
- positive edge, 182
- pre-trained model, 271
- probabilistic graph, 197
- program representation, 283
- projected gradient descent, 142
- protein, 253, 254
- protein interface, 256
- protein interface prediction, 253, 254
- protein-protein interaction, 260
- pseudo label, 273
- QA, 213
- question answering, 207, 213
- question dependent graph, 224
- random walk, 78, 174
 - biased, 89
 - meta-path based, 95
- receptor protein, 256
- recommender system, 240–244
- Rectifier, 48
- recurrent neural network, 59–63, 186, 191
- reinforcement learning, 148, 151, 283
 - action, 149, 151
 - reward, 149, 151
 - state, 149, 151
 - state transition dynamics, 151
 - terminal, 149, 151
- relation extraction, 207, 211
- ReLU, 48
- representation learning, 10
- rewiring operation, 150
- RNN, 60, 186, 211, 258
- sample-level explanation, 280
- scalability, 162
- scene graph generation, 235
- SDN, 287
- self-supervised learning, 271
- semantic embedding, 230
- semantic relation, 284
- semantic role labeling, 207–210
- semi-supervised classification, 248
- sequence model, 246
- SGD, 159, 163
- shortest path, 23, 237
- side information, 241
- sigmoid, 49
- signed graph, 36
- signed graph embedding, 99–102
- signed graph neural network, 181
- singular value decomposition, 155
- skeleton-based action recognition, 227
- skipgram, 11
- social influence, 237
- social influence prediction, 237
- social network, 237, 243
- social network analysis, 237
- social relation, 243
- social representation learning, 238
- software defined networks, 287
- software vulnerability detection, 284
- spammer detection, 247
- spamming message, 247
- spatial domain, 30, 113
- spatial relation, 245
- spatial temporal graph, 227
- spectral domain, 30
- spectral graph theory, 26
- SRL, 208–210
- SSL, 271
- stochastic gradient, 168
- stochastic gradient descent, 159, 163
- subgraph, 22, 173
- subgraph-wise sampling, 172–174
- surrogate model, 145
- SVD, 155
- syntactic dependency tree, 207, 209, 211, 225
- syntactic relation, 284
- temporal distance, 228
- temporal relation, 246, 247
- time series, 244
- traffic flow, 244
- traffic forecasting, 245

traffic network, 245
traffic prediction, 244
trail, 21
TransR, 243
travelling salesman problem, 281
tree, 191
Tree-LSTM, 191
TSP, 281
two-stage training, 272, 274
unbalanced representation, 183
undirected graph, 18
unlabeled data, 271
urban data mining, 244
user-item interaction, 243
VAE, 193
variable misuse detection, 284
variational autoencoder, 193, 286
VGG, 271
visual question answering, 222
vqa, 222
walk, 21
web data mining, 236–240
weight regularization, 71
Weisfeiler-Lehman graph isomorphism test,
276
WIKIHOP, 213
within-dimension neighbor, 179
within-dimension representation, 181
WL test, 276
word embedding, 11
word2vec, 11
zero-shot image classification, 230