

---

## Application of signal processing technique for the modification of a fruit sorting machine

---

Hiwa Golpira\*

Department of Agricultural Machinery Engineering,  
University of Kurdistan,  
P.O. Box 416,  
Sanandaj, Kurdistan, Iran  
E-mail: h.golpira@uok.ac.ir  
\*Corresponding author

Hêmin Golpîra

Department of Electrical and Computer Engineering,  
Islamic Azad University, Sanandaj Branch,  
P.O. Box 618,  
Kurdistan, Iran  
E-mail: hemingolpira@yahoo.com

**Abstract:** The objective of this study involves the optimise process of a sorting machine for spherical fruits, which are currently manually classified with a low level of efficiency in Iran. An instrumentation system is modelled and fabricated for the development of a fruit sorting machine. Mechanical components and control system are assembled on a chassis for fruit transferring and classifying. A gravity duct transfers the fruits toward six ejection points which is manipulated by pneumatic cylinders and magnetic valves. Peak signal to noise ratio (PSNR) criterion is employed to analyse the work quality of the mechatronic system. The PSNR experimental results specify that noise and vibration significantly affect the machine performance. To redesign the fabricated machine, the mechanical system of conveyor and actuators are separated from measuring and control unit. Field trials were conducted to modify the machine characteristics based on the minimum damage for the fruits. To avoid bruising in apple fruits, Golab variety, the duct slope was fixed at 0.02 which produces the maximum fruit velocity of 1 m/s. With no injury on apple fruit the sorting capacity of 130 kg/h is achieved for the machine.

**Keywords:** design; mechatronic; optimisation; peak signal to noise ratio; PSNR; fruit sorting; signal processing.

**Reference** to this paper should be made as follows: Golpira, H. and Golpîra, H. (2013) 'Application of signal processing technique for the modification of a fruit sorting machine', *Int. J. Advanced Mechatronic Systems*, Vol. 5, No. 2, pp.122–128.

**Biographical notes:** Hiwa Golpira received his MS and PhD in Agricultural Machinery Engineering from Shiraz, Iran in 1998 and Tarbiat Modares University, Iran in 2010, respectively. During 2009 to 2010, he took a scholarship from Iranian Ministry of Science, Research and Technology to study on grain combine harvesters at Kuleuven (Belgium). Currently, he is working at University of Kurdistan (Iran). His special fields of interest include design, modelling and development of agricultural equipments. Also, he applies mechatronic systems and control fundamentals in agricultural machinery.

Hêmin Golpîra received his MSc in Electrical Engineering from University of Kurdistan by 2009. He is currently working toward his PhD in Electrical Engineering at the Tarbiat Modares University, Tehran, Iran. His current research interests include power system dynamic and control, automatic generation control, robust/intelligent control applications in power systems and mechatronic systems design.

This paper is a revised and expanded version of a paper entitled 'Improvement of an apple sorting machine using PSNR criterion' presented at 2012 International Conference on Advanced Mechatronic Systems (ICAMEchS 2012), Tokyo University of Agriculture and Technology, Japan, September 18–21, 2012.

## 1 Introduction

Iranian fruit market have tendency toward automated packaging technology in recent years. Different qualitative evaluation of agricultural productions gives rise to various mechanised and automated sorting machines but culture and tradition of public, implementation of different rays, and high prices of importing technologies are the difficulties to utilise new machines for fruits sorting and grading. The increasing consumer demand for quality produces', the consistent behaviour of machines in compare with humans, the scarceness of labour and attempt to reduce costs are the main motivations of automated packing and sorting in the past decades (Moreda et al., 2009).

Certain basic factors such as size, shape, colour, taste, and freedom from defects are the commonly used ones in machines development (Chen and Sun, 1991). Most of the published researches in the state-of-the-art employ the non-size factors to develop mechanised machines. Several researchers reviewed the main advances of recent introduces automated machines in the past few years. Studman (2001) emphasises on the major impact of computer and electronic technologies in the postharvest industry. Brosnan and Sun (2004) deals with comparison of different computer vision systems to sort the fruits. García-Ramos et al. (2004) employs firmness sensors to achieve a mechanised sorter. Butz et al. (2005) reviewed the papers which introduces internal quality as a criterion for sorting.

Nevertheless, fruit size determination is important in the context of postharvest operations for fresh marketing and successful drying of fruits (Moreda et al., 2009). Size determination studies are largely used by microbial scientist to evaluate microbial population on the surface of a foodstuff. Fruit size could also provide meaningful information to employ internal quality sensors. Moreover, the shape of fruits could be estimated by means of fruit size.

Owing to these features, the fruit sorting based on its size could cover the advantages of other sorting methods. It should be noted that, fruit size can be expressed in terms of volume, weight, and diameter. Among the different size-based approaches, electronic weighting is the most widespread and suitable technique used in fresh produce packing houses (Moreda et al., 2009). Therefore development of a sorting machine based on weight could provide a flexible platform which implements other sorting factors with a little architecture changes.

Sorting process consists of three phases including fruit weight measurement, decision making and separation along different takeaway cross a transfer duct (Golpira and Golpîra, 2012). In other words, a weight-based system consists of mechanic, electronic and control units which work on data acquisition and digital signal processing basis. Load cell plays an important role in a weight-based sorting mechanism. Strain gages which inserted on a load cell sense the fruit weight. Load cells usually connected to a bridge circuit to yield a voltage proportional to the load (Alciatore

and Histan, 2007). Its output voltage is in the range of a few volts which could be significantly affected by noises.

Therefore a special consideration should be taken into account regarding load cell output signal. On the other hand, mechatronic systems involve devices that require some sort of intelligent control based on various inputs which done by microcontrollers. Microcontroller includes signal processor and recorder which are the other fundamental parts of mechatronic systems (Isermann, 1996).

This paper develops and modifies a fruits sorting machine based on signal processing technique. Peak signal to noise ratio (PSNR) criterion is employed to optimise measuring and control systems of the fruit sorting machine. Based on the authors knowledge this is the first time that the signal processing technique especially image processing technique of PSNR is employed to enhance a mechatronic system performance. Although, the machine was designed and modelled, the presented paper focuses on PSNR-based optimisation of the mechatronic system.

The rest of this paper organised as follows. Section 2 describes the design methodology. Section 3 explains simulation and experimental results in detail. Section 4 describes simulation and experimental results and signal quality analysing in detail. Section 5 describes the calibration of the machine for apple fruit, and finally Section 6 concludes the paper.

## 2 Problem formulations

The development of a sorting machine for spherical fruits is purposed. Physical modelling, PSNR-based optimisation and machine evaluation are the design procedure to develop a fruit sorting machine. Physical model of the machine designed and developed while they were modified via evaluations. Mechanical components, measuring system and digital control architecture are applied for transferring, sensing and interfacing of the sorting machine. Figure 1 illustrates the major components and interconnections in the sorting mechanism. The machine optimisation procedure was characterised by the interaction between the field evaluation and signal processing technique.

A PSNR-based evaluation was established for the evaluation of the machine. To reserve the real process of design, the optimisation steps were mentioned exactly according to actual design procedure. The modification process consists of the following steps:

- fabrication of the physical model for the sorting machine
- design of instrumentation and control system
- PSNR-based evaluation for the performance of the model
- field evaluation and modification of the system based on the apple damage.

Figure 1 Control unit diagram of the grading machine

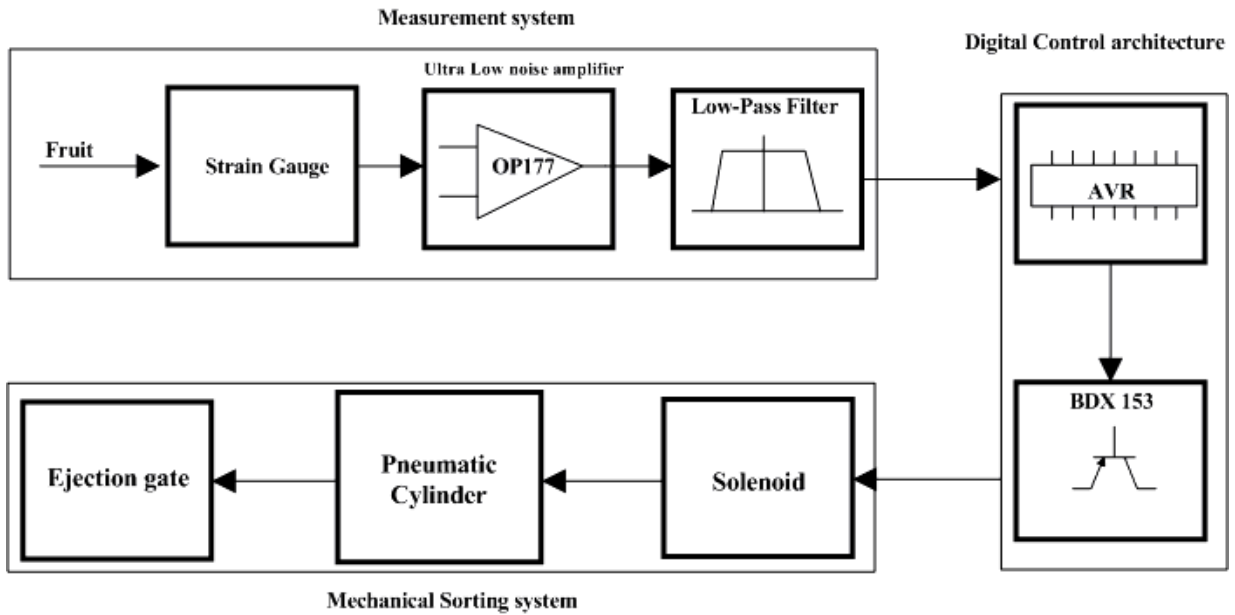
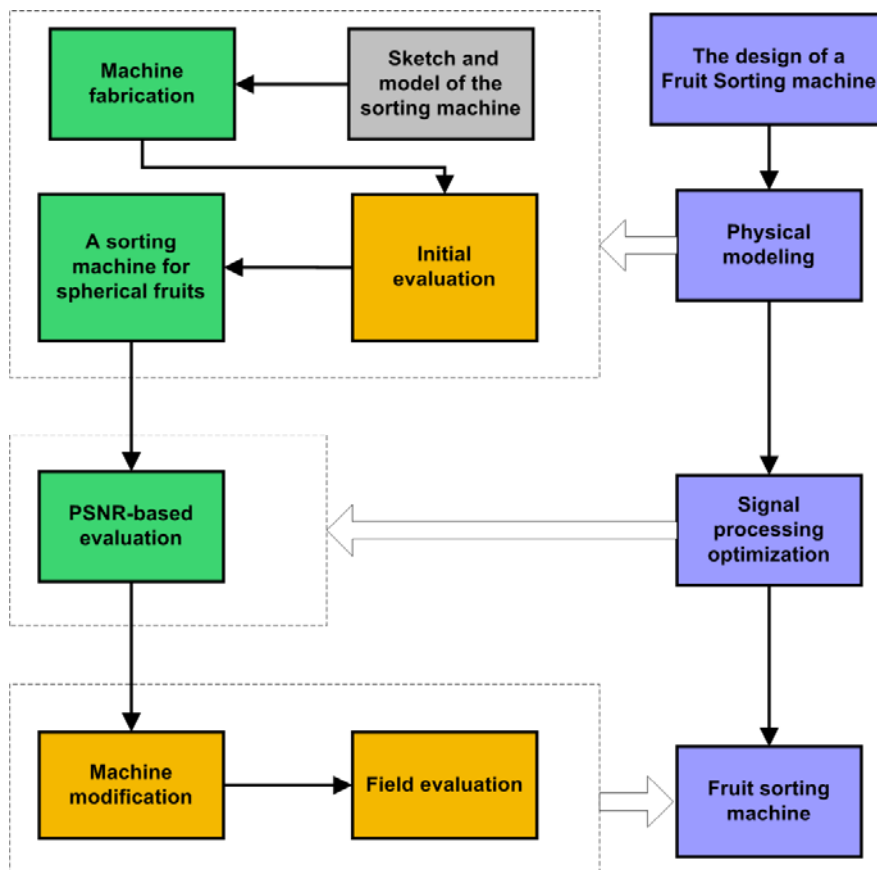

Figure 2 The experimental machine for apple grading



### 3 Design methodology

The design relies on the integration of mechanical, biosystem and control engineering. Figure 2 illustrates the major components and interconnections in the sorting mechanism. The sorting procedure based on fruit weight divided into three phases as follows:

- 1 data acquisition (measuring and digitalising the load cell signal)
- 2 classification (estimating the fruit weight)
- 3 actuation (moving gates corresponding the fruit weight).

### 3.1 Fabrication of a model for sorting machine

A primary model is designed for the proposed machine in SolidWorks 2009 as depicted in Figure 3. According to the suggested model, the experimental machine is fabricated as shown in Figure 4.

A weight sensing system measures the fruit weight and a duct with a 20-cm working width transfer the fruits to the chutes (Golpira, 2011). Their gates are manipulated by pneumatic cylinders and magnetic valves which controlled by the weight control system. The designed machine employs load cell to classify the fruits in 6 categories.

### 3.2 Instrumentation and control

A load cell which contains an internal flexural element with two strain gages mounted on its surface was used. Using load cell in fabrication of a machine requires several considerations regarding its amplification. The load cell output signal pre-filtered before being amplified in order to eliminate noises. The amplified signal from load cell fed to the microcontroller for further actions.

Microcontroller ATMEGA 32 is employed as decision making unit which produces command signal to the magnetic valves. It should be noted that to drive the

magnetic valves by means of microcontroller ports, its output current should be amplified before applying to the valves. For this proposes integrated circuit (IC) BDX 53 in common collector form is employed to amplifies the output port current. The control diagram is successfully simulated by the Proteus software.

The load cell with rated capacity of 2 kg and 1 mV/V sensitivity is employed for the measuring unit. The excitation voltage and the maximum achievable voltage are 10 (Volt) and 10 (mV), respectively. The output voltage is so low that can not drives the valves correctly. Amplifying the output signal of the load cell is done by using ultra-low-noise amplifier (OP177). The precision high gain differential amplifier scheme is illustrated in Figure 5. As the output signal modulated with noises, it must be pre-filtered by a low pass filter in order to achieve an acceptable DC signal for microcontroller.

After weight measuring and processing, the microcontroller determine which solenoid, excited with 12 (volt) DC, is articulated. Double-acting pneumatic cylinders produce motion for ejection points. The solenoid actuates air control valve to manipulate cylinder and thereby ejection points. A pump with two cylinders compresses the air in a 220 litre reservoir. The control valves are speed, model 4A220-08, with rated pressure of 0.15 to 0.8 MPa.

**Figure 3** The sorting machine model

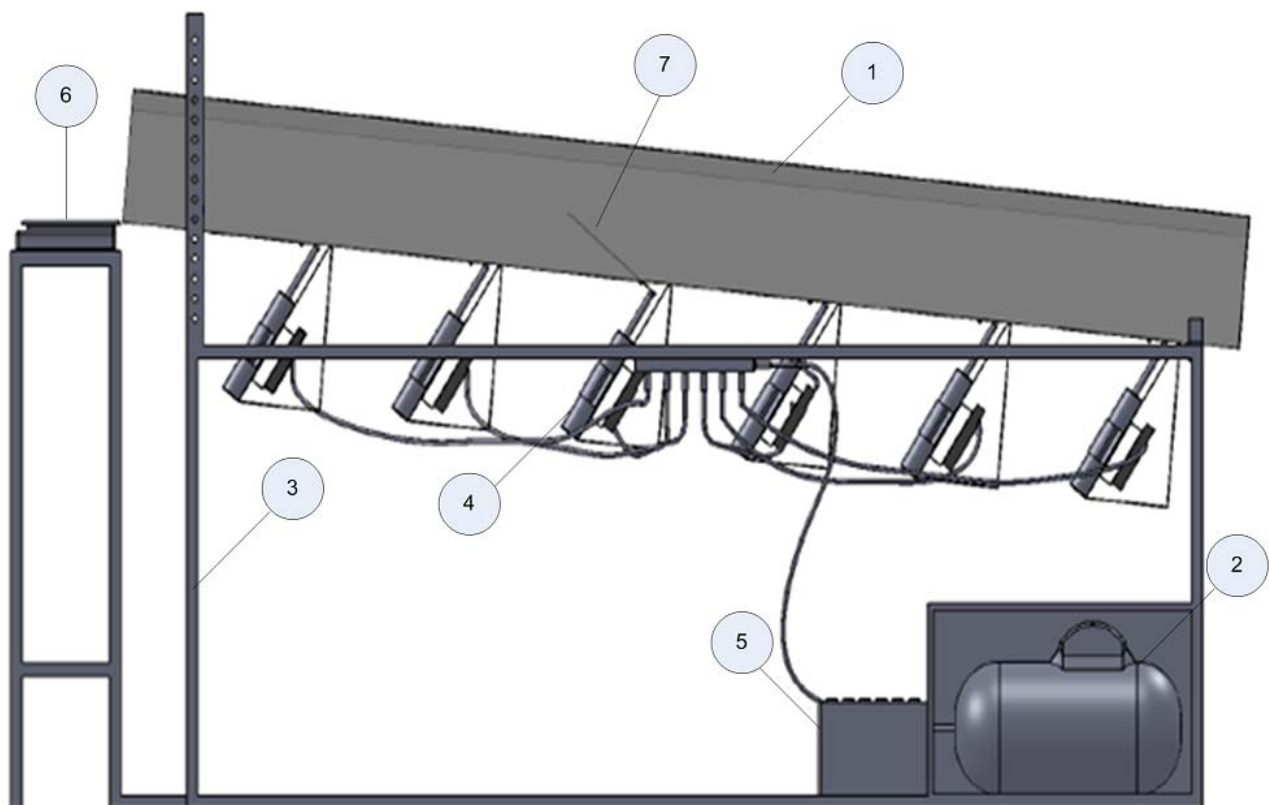

Notes: 1 – duct, 2 – pneumatic pump, 3 – frame, 4 – pneumatic cylinder, 5 – electrical motor, 6 – weight sensing unit, 7 – chute

**Figure 4** The experimental machine spherical fruit sorting

(a)

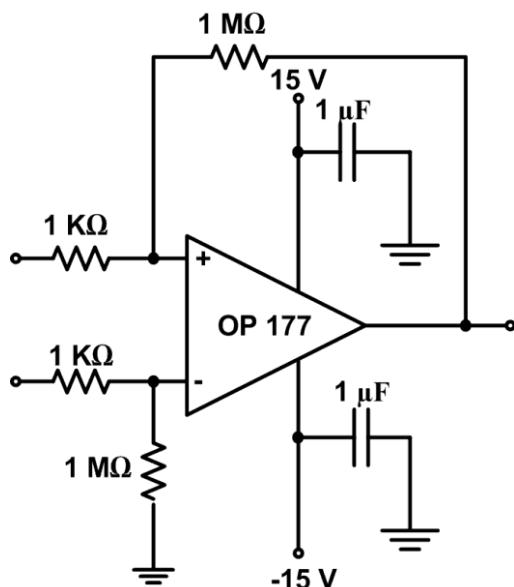

(b)

**Figure 5** Precision high gain amplifier

### 3.3 PSNR

The signal quality assessment criterion named PSNR is employed to analyse the impact of noise and digitalisation accuracy on the machine performance. PSNR criterion is employed to overcome the challenges associated with load cell signal amplification. PSNR is the ratio between the peak of a signal and the power of noise that affects the fidelity of the signal representation. It is expressed in terms of the logarithmic decibel scale and widely used in the image and video signal processing (Golpîra and Danyali, 2011). PSNR is simple, well defined, with clear physical measuring and widely accepted (Lin and Kuo, 2011). Modification of the machine based on PSNR results give rises to the machine with acceptable performance.

## 4 Simulation and experimental results

The proposed control and measuring system examined by Proteus is implemented in experimental machine.

As stated previously, the excitation voltage of load cell is considered to be 10 (Volt). Therefore the maximum achievable voltage at the load cell terminal is 10 (mV). The maximum probable weight for the examined apples considers as 500 (gr) which produces 2.5 (mV) at the output port. This voltage level is so low to be processed by microcontroller on which drives the valves correctly. Amplifying the output signal of load cell is done by using ultra-low-noise amplifier (OP177). As the load cell output signal is a DC one with constant value for each fruit, the added noise to the desired signal could be easily removed. Therefore, a low pass filter is implemented in order to eliminate the unwanted environmental noises as well as machine vibration.

As stated previously, gravity conveyor, measuring and control system and actuators (pneumatic cylinders) are the main parts of the mechatronic system. At the first step the controlling and measuring systems are implemented in the same chassis as transferring system. The experimental results show that the control system only drives the three latest pneumatic cylinders. In other words, the apples with weights in range of 0–80 (gr) pass through the duct and fall in the end of it. The only parameter which could affect the performance of the machine seems to be noises. To evaluate impact of this unwanted parameter on the machine performance, PSNR criterion is implemented.

Figure 6 demonstrates the PSNR results for the load cell output signals related to the various apple weights. It is noteworthy that the PSNR is calculated between the real amplified signal and the desired one which is a load cell output signal multiplied at the amplification gain. It could be clearly seen that there is a significant decrease in the PSNR for the low output signals. This means that in the low level of voltages related to the lower weights, the noise signal becomes dominant in compare with the load cell desired signals. In the amplifying stage the employed equipments are the accurate and ultra low noise ones on which introduce negligible noises in the system.

**Figure 6** PSNR results for the various weights

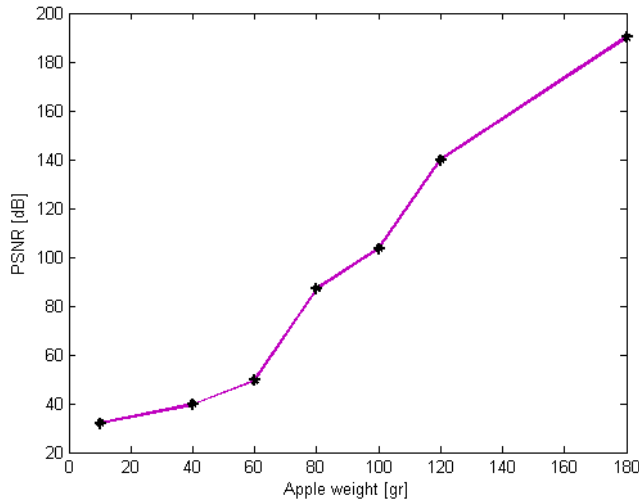

Therefore, it seems that the vibration give rises from pneumatic cylinders reaction affect the system performance. Therefore, the chassis divided into two parts, one as controlling and measuring system and the other as transferring duct. Figure 7 demonstrates the comparison between PSNRs for the system with one and two chassis. It could be clearly seen that PSNR significantly improved in the lower weights range. Experimental results also prove the PSNR results. In other words, after dividing the chassis to two parts, all the apples are sorted based on their sizes without any concerns. Values for the PSNR in amplified signals are between 85 and 190 db, which are accepted.

**Figure 7** PSNR comparison for the combined and separated chassis

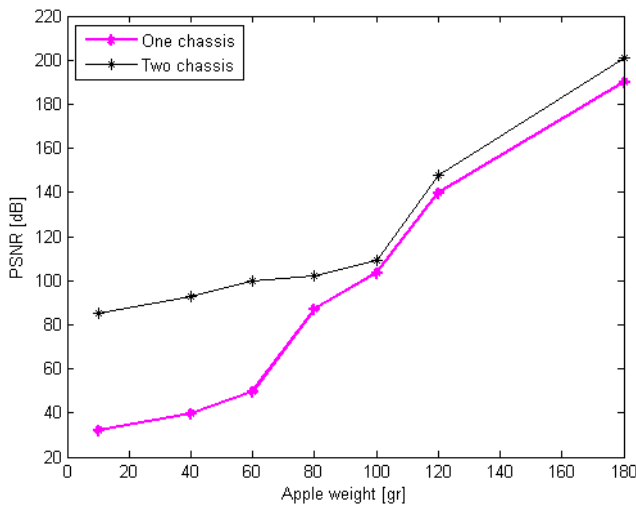

### 5 Evaluation of the machine for apple fruit

Reduction of fruit damage is an important issue and could be explained as the bottleneck of grading machine design. Damage occurs as a result of machinery roughness and the susceptibility inherent of fruit during fruit transferring in the duct. A visible bruise threshold of 100 (mm<sup>2</sup>) is a typical value used in industry for determining which apples should

be discarded due to damage (Lewis et al., 2007a, 2007b). Therefore, several considerations should be made in designing transfer duct as it significantly affects the fruit damage.

As the sorting machine is general purposes and designed for spherical viscoelastic objects, the duct angle can be adjusted according to fruit defect characteristics. The duct height adjusted by an adjustable screw mounted on the machine frame depends on fruit damage susceptibility. After machine fabrication and optimisation, its performance is studied for apple fruit. Theoretical and practical evaluation is performed to determine the incline angle and machine performance. The experiments were conducted in the Sanandaj orchards in Kurdistan province, Iran, during the summer of 2009 using a very common apple variety, Golab. To protect fruit bruising, the fruits were harvested carefully by hand. The fruits weights were 40–130 ± 0.1 gr. The established decision rules for the microcontroller are illustrated in Table 1.

**Table 1** Apple fruit classification and solenoid control

Gate no.	Classification	Control port of solenoids
If 1	$x < 40$	Then 0 0 0 0 0 1
2	$40 \leq x < 60$	0 0 0 0 1 0
3	$60 \leq x < 80$	0 0 0 1 0 0
4	$80 \leq x < 100$	0 0 1 0 0 0
5	$100 \leq x < 120$	0 1 0 0 0 0
6	$x \geq 120$	1 0 0 0 0 0

To determine the best angle with respect to fruit damage, the duct angle was optimised. The classified apples were inspected with respect to bruising, which is most common result of impact force on apple fruit. After 24 hours the fruit damaged was inspected with naked eye (Zeebrock et al., 2007a, 2007b). Increasing duct angle results rising fruit velocity. At the last gate the fruit speed is more than the others. The fruit velocity ( $v$ ) calculated as in the following.

$$\frac{1}{2}mv^2 = mgh \tag{1}$$

where  $m$  is the mass of the fruit (kg),  $v$  is the fruit velocity (m.s<sup>-1</sup>),  $g$  is the gravity acceleration (m.s<sup>-2</sup>) and  $h$  is the height (m). By substituting the critical height of bruising, for Golab variety of apple fruit, of 6 cm (Golpira et al., 2010) in equation (1) the maximum fruit velocity at duct is 1 m.s<sup>-1</sup>. Therefore to avoid mechanical damage in fruits, the duct slope was fixed at 0.02.

The experimental data were analysed using a variance analysis to determine the fruit bruising based on bruising damage after the process on apple different region (Figure 8). The means of the treatments (damage) were compared with Duncan’s multiple range tests at a one percent level of significance for the machine. It is noteworthy that, the statistical analyses and initial

experiments, which are done to modify the sorting machine, are not remarked here. Only the results and design procedure is discussed.

Fruit damage analysing during the sorting process demonstrated that the machine has no injury on apple fruit. Machine capacity is the fruits weight which is graded per hour by the machine. It was determined that two seconds is needed to receive a fruit from the load cell to the last gates. If the average weight of an apple fruit considered 0.07 kg, the grading capacity of the machine is 130 kg/h for the machine width of 20 cm.

**Figure 8** Apple fruit region in damage inspect

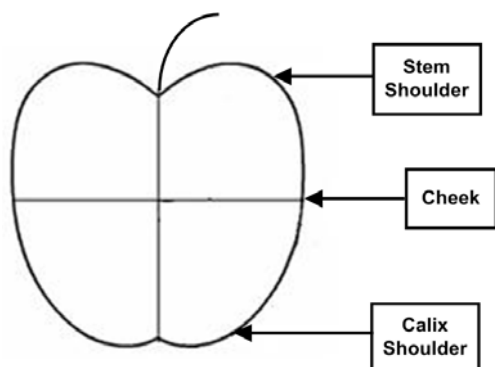

## 6 Conclusions

The need for postharvest technology driven by the demand for quality produces and increasing price of food are the main motivations for design of a sorting machine. A weight-based sorting machine was fabricated for spherical fruits based on the available technology in the region. Measuring system and control unit, pneumatic cylinders, solenoid and gravity conveyor are the main parts of the mechatronic system.

The signal quality assessment criterion named PSNR is employed to analyse the impact of noise and digitalisation accuracy on the machine performance. PSNR-based optimisation beside field evaluation approves acceptable classification for apple fruit.

Furthermore, application of video and image processing technique for the modification of postharvest equipments is unique ever published.

## References

- Alciator, D.G. and Hstand, M.B. (2007) *Introduction to Mechatronics and Measurement Systems*, Mc-Graw Hill, NY, USA.
- Brosnan, T. and Sun, D.W. (2004) 'Improving quality inspection of food products by computer vision – a review', *Journal of Food Engineering*, Vol. 61, No. 1, pp.3–16.
- Butz, P., Hofmann, C. and Tauscher, B. (2005) 'Recent developments in noninvasive techniques for fresh fruit and vegetable internal quality analysis', *Journal of Food Science*, Vol. 70, No. 1, pp.131–141.

- Chen, P. and Sun, Z. (1991) 'A review of non-destructive methods for quality evaluation and sorting of agricultural products', *Journal of Agriculture Engineering Research*, Vol. 49, No. 9, pp.85–98.
- García-Ramos, F.J., Ortiz-Cañavate, J. and Ruiz-Altisent, M. (2004) 'Evaluation and correction of the mechanical aggressiveness of commercial sizers used in stone fruit packing lines', *Journal of Food Engineering*, Vol. 63, No. 2, pp.171–176.
- Golpîra, H. and Danyali, H. (2011) 'Reversible medical image watermarking based on wavelet histogram shifting', *Imaging Science Journal*, Vol. 59, No. 1, pp.49–59.
- Golpira, H., Golpira, H. and Hoseinzadeh, B. (2010) 'Design, development and investigation of a weight sorting automatic machine for apple', *Journal of Food Research*, Vol. 19, No. 2, pp.38–47.
- Golpira, H. (2011) *The Design and Development of a Fruit Sorter*, I.R. Patent No. 68915, 23 February.
- Golpira, H. and Golpîra, H. (2012) 'Improvement of an apple sorting machine using PSNR criterion', *Proceedings of the 2012 International Conference on Advanced Mechatronic Systems*, Tokyo, Japan, September 18–21, pp.729–732.
- Isermann, R. (1996) 'Modeling and design methodology for mechatronic systems', *IEEE/ASME Transactions on Mechatronic*, Vol. 1, No. 1, pp.16–28.
- Lewis, R., Yoxalla, A., Cantya, L.A. and Romo, E.R. (2007a) 'Development of engineering design tools to help reduce apple bruising', *Journal of Food Engineering*, Vol. 83, No. 3, pp.356–365.
- Lewis, R.A., Yoxall, A., Marshall, M.B. and Canty, L.A. (2007b) 'Characterizing pressure and bruising in apple fruit', *Wear*, Vol. 264, Nos. 1–2, pp.37–46.
- Lin, W. and Kuo, C.C.J. (2011) 'Perceptual visual quality metrics: a survey', *Journal of Visual Communication and Image Representation*, Vol. 22, No. 4, pp.297–312.
- Moreda, G.P., Ortiz-Cañavate, J., García-Ramos, F.J. and Ruiz-Altisent, M. (2009) 'Non-destructive technologies for fruit and vegetable size determination – a review', *Journal of Food Engineering*, Vol. 92, No. 2, pp.119–136.
- Studman, C.J. (2001) 'Computers and electronics in postharvest technology – a review', *Computers and Electronics in Agriculture*, Vol. 30, Nos. 1–3, pp.109–124.
- Zeebroeck, M.V., Vanlinden, V., Darius, P., Deketelaere, B., Ramon, H. and Tijskens, E. (2007a) 'The effect of fruit factors on the bruise susceptibility of apples', *Postharvest Biology and Technology*, Vol. 46, No. 1, pp.10–19.
- Zeebroeck, M.V., Vanlinden, V., Ramona, H., Baerdemaekera, J.D., Nicolaïa, B.M. and Tijskens, E. (2007b) 'Impact damage of apples during transport and handling', *Postharvest Biology and Technology*, Vol. 45, No. 2, pp.157–167.

## Nomenclature

$m$	Mass of the fruit (kg)
$h$	Drop height (m)
$g$	Gravity acceleration ( $m.s^{-2}$ )
$v$	Fruit velocity ( $m.s^{-1}$ )
SNR	Peak signal to noise ratio (db)